



www.heatlink.com

Job or Customer :	
Location :	
Engineer :	
<input type="checkbox"/> Complies with Spec <input type="checkbox"/> Alternate	Notes :
Contractor :	
HeatLink Rep :	
Submitted By :	Date :
Approved By :	Date :
P.O. Number :	Date :

Description

These Snow Melt Panels are operation centers for fully automatic snow melt systems. They are intended for snow melt systems with non-dedicated heat sources, therefore heat exchangers are included to separate the primary loop water from the secondary loop glycol mixture. The included 30654 snow melt control uses Snow/Ice Detector #30090 and Snow/Ice Sensor Socket #30091 (both sold separately).

Qty	Stk. #	Nominal Panel Output	Primary Circulator	Secondary Circulator	Heat Exchangers	Weight
	SMP175-654-HEX	175,000 Btu/hr	Ferrous, Grundfos UPS26-99FC	Ferrous, Grundfos UPS26-99FC	2× Single-wall brazed plate; FP3×8-20	93.5 lb (42.5 kg)
	SMP300-654-HEX	300,000 Btu/hr	Ferrous, Grundfos UPS26-99FC	Ferrous, Grundfos UPS26-99FC	2× Single-wall brazed plate; FP3×8-30	
	SMP300-654-HEX-H	365,000 Btu/hr	Ferrous, Grundfos UPS26-99FC	Ferrous, Grundfos UPS26-150FC	3× Single-wall brazed plate; FP3×8-30	
	SMP300-654-HEX-HH	365,000 Btu/hr	Ferrous, Grundfos UPS26-150FC	Ferrous, Grundfos UPS26-150FC	3× Single-wall brazed plate; FP3×8-30	

Panel Output Conditions	SMP175SS-654-HEX		SMP300SS-654-HEX		SMP300SS-654-HEX-H		SMP300SS-654-HEX-HH	
	Primary	Secondary	Primary	Secondary	Primary	Secondary	Primary	Secondary
Fluid type	Water	50% glycol	Water	50% glycol	Water	50% glycol	Water	50% glycol
Entering fluid temp (°F)	185.0	110.0	185.0	110.0	182.0	110.0	182.0	110.0
Exiting fluid temp (°F)	155.0	141.2	155.0	143.7	152.0	142.8	152.0	142.8
Flow rate (US gpm)	12.0	12.6	20.6	20.0	24.9	24.9	24.9	24.9
Headloss	4.1	-	7.0	-	2.5	-	2.5	-
Allowable pressure drop outside of panel (ft head)	-	18	-	10	-	20	-	20

Technical Data

	Specifications
Max ambient temperature	120°F (49°C)
Max water temperature	200°F (93°C)
Max operating pressure	125 psi (862 kPa)
Temperature control method	3-way mixing valve with DDC motor
Mixing valve size	1¼"
Mixing valve Cv	11.6
Temperature control range	50-180°F (10-82°C)
Power supply	Hard-wired, requires shut off switch for maintenance/repairs, 15 Amp, 120V, 60Hz, single phase
Auxiliary terminal	1
Piping	1" 304SS Tubing
Piping connections	¾" and 1" FNPT
Material - backplate	16 Gauge galvanized steel
Material - enclosure	Powder coated steel

Options

OPT-SMP-680 - replace standard snow melt control with #31680 Snow/Ice Detector and Melt Control (see SUB31680)

Note: When ordering, please include a copy of the completed submittal.

Standards / Listings

CAN/CSA-C22 No.14, UL508
 cETLus

Panel Diagrams

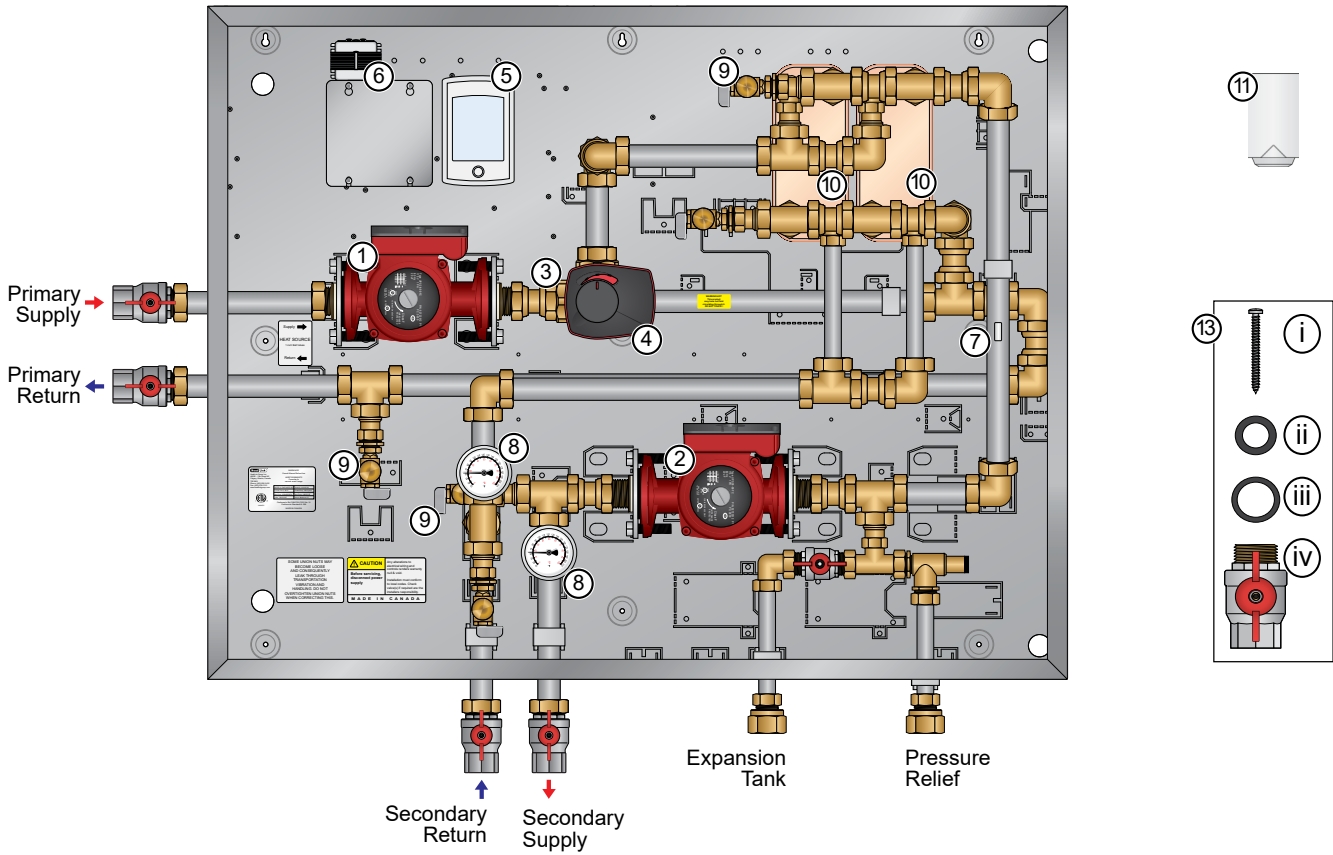

Panel Components

- ① Primary Pump
- ② Secondary Pump
- ③ 1 1/4" Mixing valve (hidden)
- ④ DDC Mixing Valve Motor
- ⑤ Snow Melt Control
- ⑥ 24V Transformer
- ⑦ Supply Sensor
- ⑧ Strap-on Thermometer
- ⑨ Drain and Fill Valve
- ⑩ Heat Exchanger
- ⑪ Outdoor Sensor (#30070)
- ⑫ Cover
- ⑬ Accessory Pack
 - i Mounting Screw
 - ii 3/4" Nitrile washer
 - iii 1" Nitrile washer
 - iv 1" Isolation valve (shown installed)



Panel Dimensions

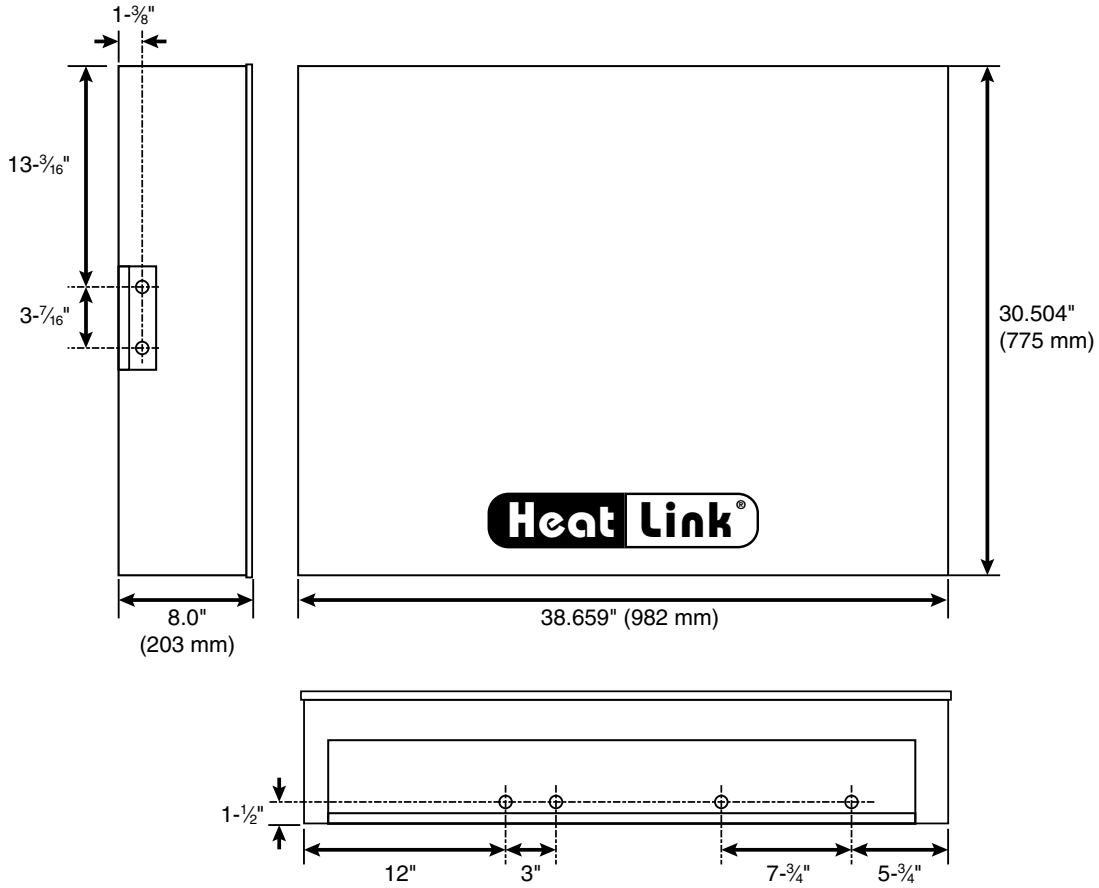

FT HD Outside of Panel

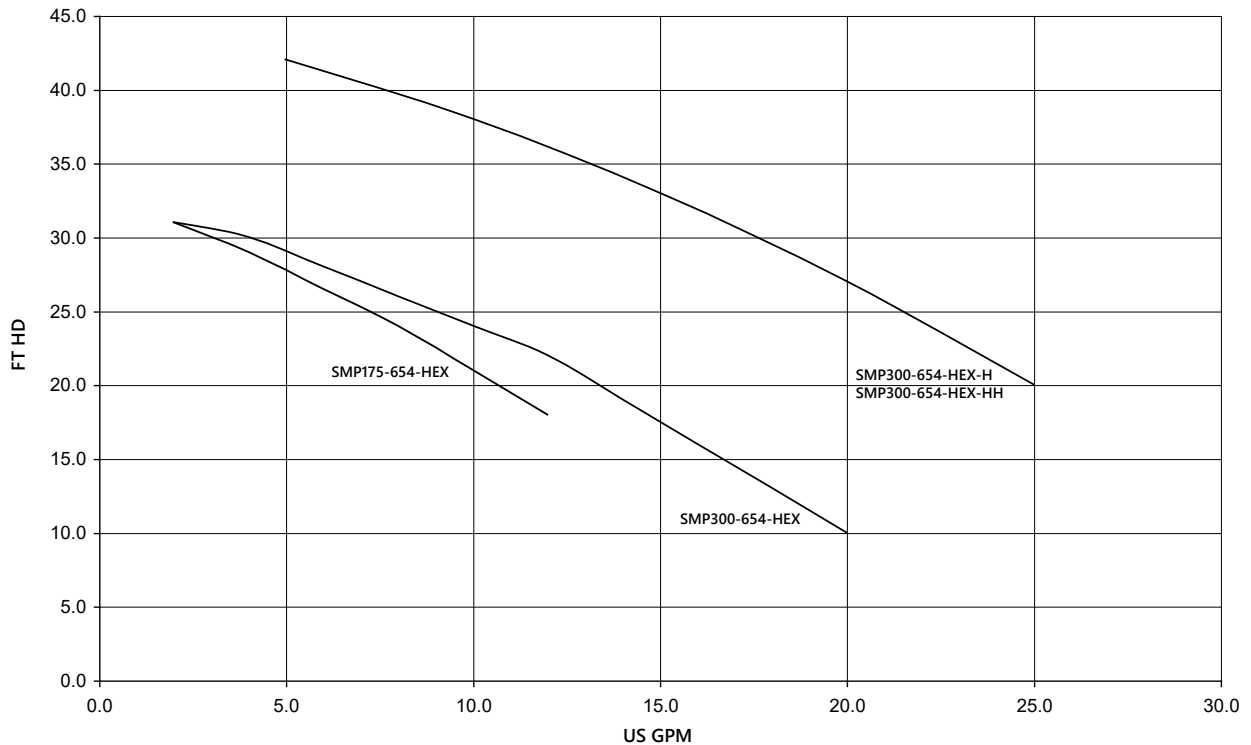

Pump Curves

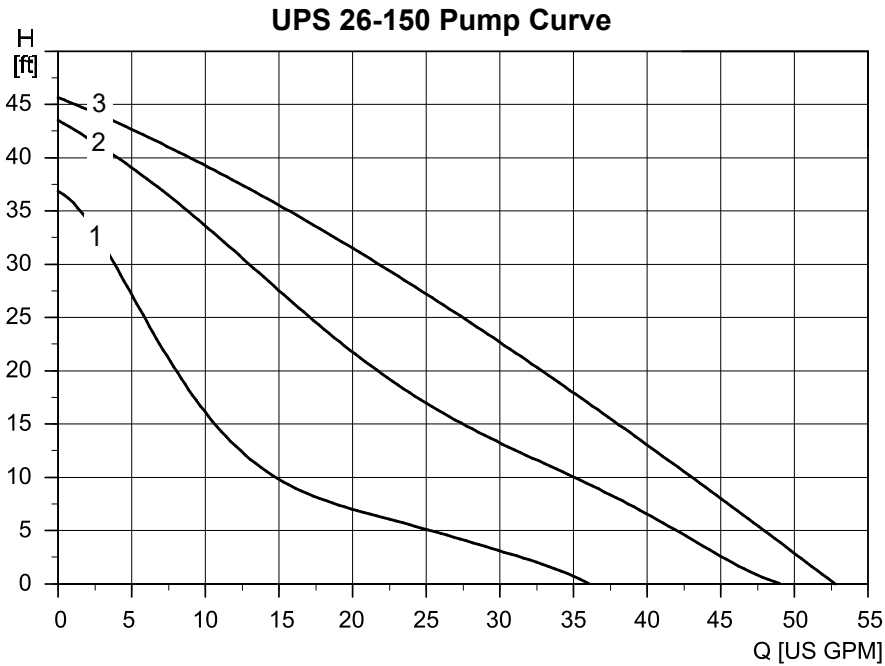
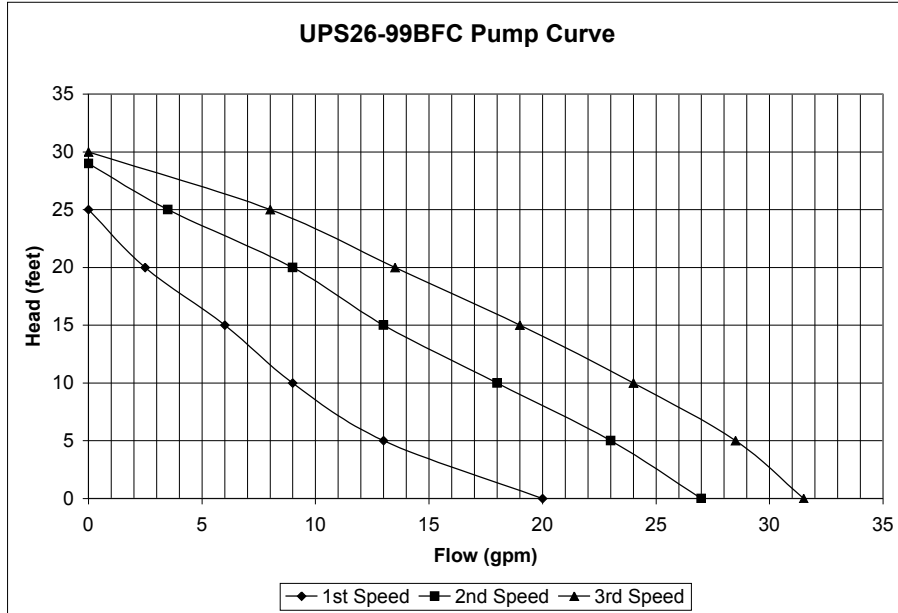

Installation

Installation must follow all of HeatLink's instructions and guidelines.

Maintenance

Maintenance must follow all of HeatLink's instructions and guidelines.

Related Documents

- Operation and Maintenance Manual (L6SMP000-654-HEX)
- HeatLink Limited Heating Warranty