

Job or Customer :	
Location :	
Engineer :	
<input type="checkbox"/> Complies with Spec <input type="checkbox"/> Alternate	Notes :
Contractor :	
HeatLink Rep :	
Submitted By :	Date :
Approved By :	Date :
P.O. Number :	Date :

**Description**

The 10005 HeatLink Galvanized PEX Tubing Dispenser is invaluable for tubing installation. Made of galvanized steel for long-term durability and maintenance free operation. Easy assembly and disassembly without tools.

**Technical Data**

Material:.....Galvanized steel  
 PEX diameter: .....up to 3/4"  
 Max coil weight:.....114.6 lb (52 kg)  
 Max coil height: .....24" (60 cm)  
 Min inner coil diameter: .....11 1/2" (29 cm)  
 Max outer coil diameter:.....44" (112 cm)

Qty	Stk. #	Weight
	10005	39 lb (17.7 kg)

**Dimension Diagram**

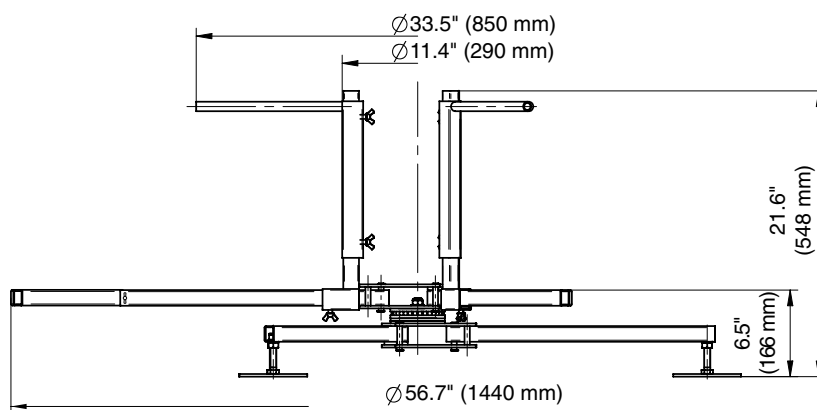

**Related Documents**

- HeatLink Limited Plumbing Warranty

*This page is intentionally blank.*