

# Heat Link<sup>®</sup>

## TFT-01, TFT-02

### Trinity Boiler Panels Installation, Operation, and Maintenance Manual

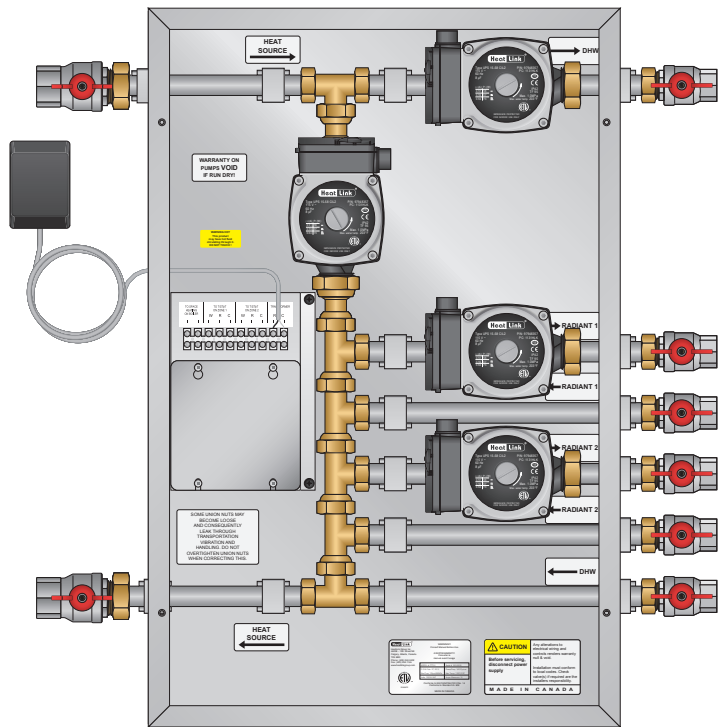
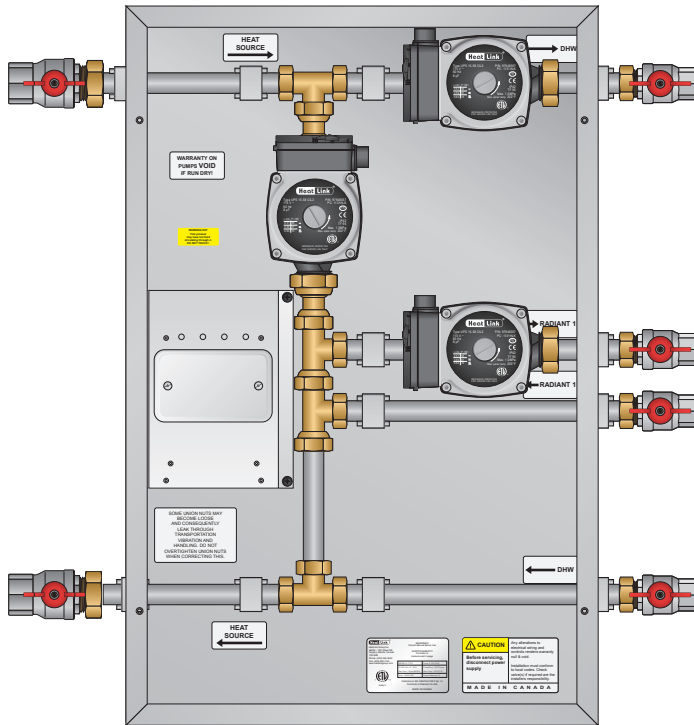

**Table Of Contents**

Warnings.....	3
Tools Needed .....	3
Function.....	4
Unpacking.....	4
Panel Components .....	5
Specifications.....	6
Dimensions.....	7
Panel Component Specifications .....	8
Mounting.....	9
Piping Hookup .....	10
Fill and Purge .....	11
Panel Control Sequence & Wiring.....	12-13
Troubleshooting .....	14
Maintenance .....	15
Schematics	
Mechanical .....	16-17
Electrical Rough-in .....	18-20
Electrical Detail .....	21-22

## Warnings

The BC G2 panel is for indoor use only and must be installed by a qualified installer/service technician. This product must be installed and operated in strict accordance with the terms set out in this manual and in accordance with the relevant requirements of the Local Authority Having Jurisdiction. Failure to comply will result in a void of warranty, and may also result in property damage, serious injury, or death.

## Servicing

Prior to commencing installation of this panel it is necessary to read and understand all sections of this manual. The symbols below are used throughout this document to ensure proper operation of the



Warning  
**Possible Hazard**



Warning  
**Live Power**



Warning  
**Hot Pipes**



Warning  
**Treated Water**



*In order to avoid injury or death, switch off the power to the panel prior to inspecting or making connections to the terminal strip.*

panel, and your safety. Please pay attention to these symbols.

## Disclaimer

HeatLink Group Inc. shall not be responsible for errors in its brochures or printed materials. HeatLink Group Inc. reserves the right to alter its products at any time without notice, provided that alterations to products already on order shall not require material changes in specifications previously agreed upon HeatLink Group Inc. and the Purchaser. All trademarks in this material are property of the respective companies. HeatLink and the HeatLink logotype are trademarks of HeatLink Group Inc. All rights reserved.

## Tools For Installation

- Level
- Screwdriver or power drill
- Flat head bit
- Phillips head bit # 2
- 2 adjustable wrenches (or 2x 30mm wrenches and 2x 40mm wrenches)

## Function

This panel is specially designed to work with the BC1 boiler and can provide distribution and zoning for a wide variety of hydronic heating applications.

The effectiveness of the system is dependant on the system being designed and installed correctly. Proper consideration of factors such as BTU loads, outdoor design temperature, indoor design temperature, room set-point temperature(s), differential fluid temperatures, head loss, flow rates, and transfer capacities of the heat emitters is critical.

Once these factors have been considered and the system requirements determined, these can then be evaluated and compared to the zone control panel capabilities (refer to pages 5-8).

**Note:** *This panel does not regulate or monitor the operating safety limit temperatures of the fluid leaving the heat source.*

---

## Unpacking

- Step 1** Examine carton for any damage that may have occurred during shipping. If damage is visible notify your courier and supplier right away.
- Step 2** Remove the staples and open the carton.
- Step 3** Remove the cardboard spacers, then remove the panel from the carton. Lift the panel by the base, never by the cover!
- Step 4** Remove the 4 screws holding the cover in place.

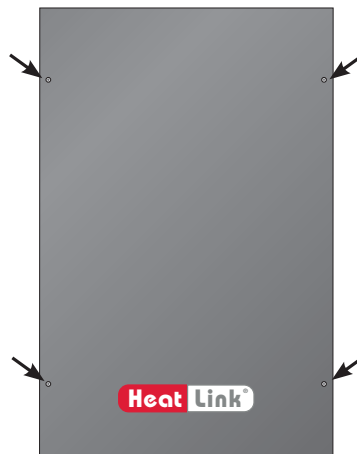

**Step 5** Remove the cover from the panel.

**Step 6** Verify the following items:

- Installation, Operation and Maintenance Manual
- Accessory Pack (see next page for details)
- 1 x 40VA Plug-In Transformer (TFT-02 only)

### Panel Components

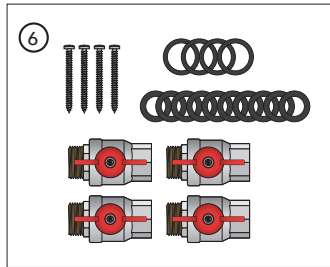
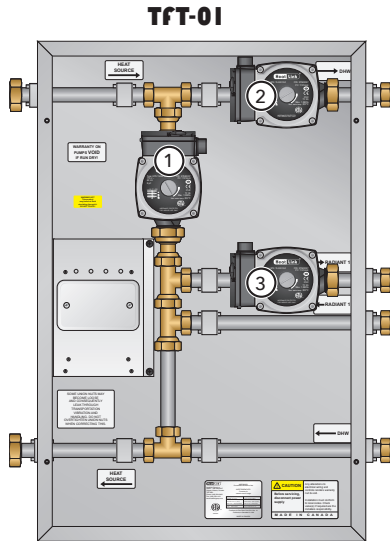

- (4) Mounting Screws
- (4) 3/4" M G x 3/4" FNPT Ball Valves
- (2) 1" M G x 1" FNPT Ball Valves
- (8) 3/4" Rubber Washers
- (4) 1" Rubber Washers

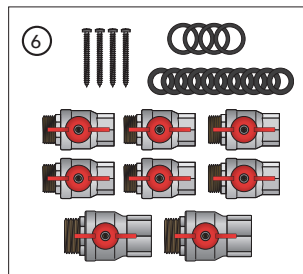
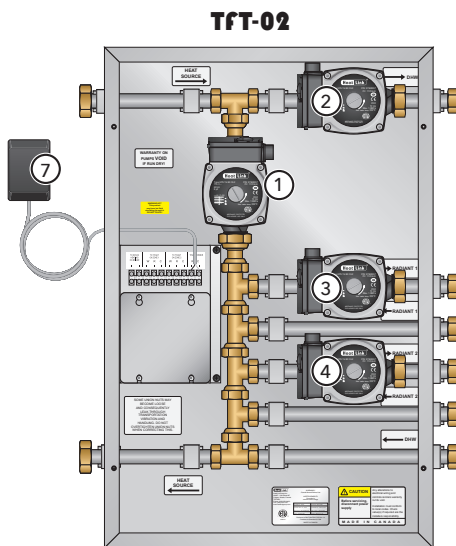
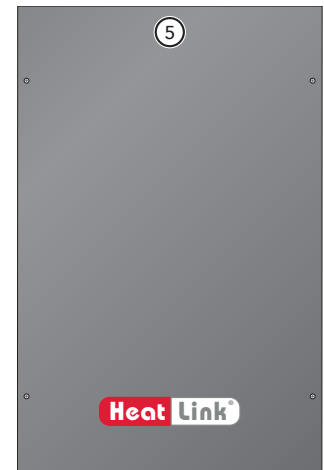

- (4) Mounting Screws
- (6) 3/4" M G x 3/4" FNPT Ball Valves
- (2) 1" M G x 1" FNPT Ball Valves
- (12) 3/4" Rubber Washers
- (4) 1" Rubber Washers

#	Component	Part Number	
		BC G2-1	BC G2-2
①	Primary Circulator	PUMP1558	PUMP1558
②	Radiant 1 Circulator	PUMP1558	PUMP1558
③	Radiant 2 Circulator	n/a	PUMP1558
④	DHW Circulator	PUMP1558	PUMP1558
⑤	Cover	n/a	n/a
⑥	Accessory Pack	ACCBG2-1	ACCBG2-2
⑦	Plug-in Transformer	n/a	PLINTR40VA

## Specifications

	TFT-01	TFT-02
Listing	cETLus	
Conforms to	CAN/CSA-C22 No.14, UL508	
Dimensions	26.566"H x 17.609"W x 7.628"D	
Nominal panel output	80,000 btu/hr	100,000 btu/hr
Nominal flow	6.0 US gpm @ 35°F ΔT	10.0 US gpm @ 35°F ΔT
Max ambient temperature	120°F (49°C)	
Min operating temperature	40°F (4°C)	
Max operating temperature	200°F (93°C)	
Max operating pressure	125 psi (862 kPa)	
Power requirements	120 V(ac)/24 V(ac) 60 Hz	
Primary circulator	Non-ferrous, Grundfos UPS15-58	
Radiant 1 circulator	Non-ferrous, Grundfos UPS15-58	
Radiant 2 circulator	n/a	Non-ferrous, Grundfos UPS15-58
DHW circulator	Non-ferrous, Grundfos UPS15-58	
Auxiliary terminal	2 dry contacts, max. load 1.5A	
Piping	¾" 304 Stainless steel tubing	
Piping connections	¾" and 1" FNPT	
Backplate and enclosure	16 gauge galvanized steel	
Cover	Powder coated steel	

**Dimensions**

**TFT-01**

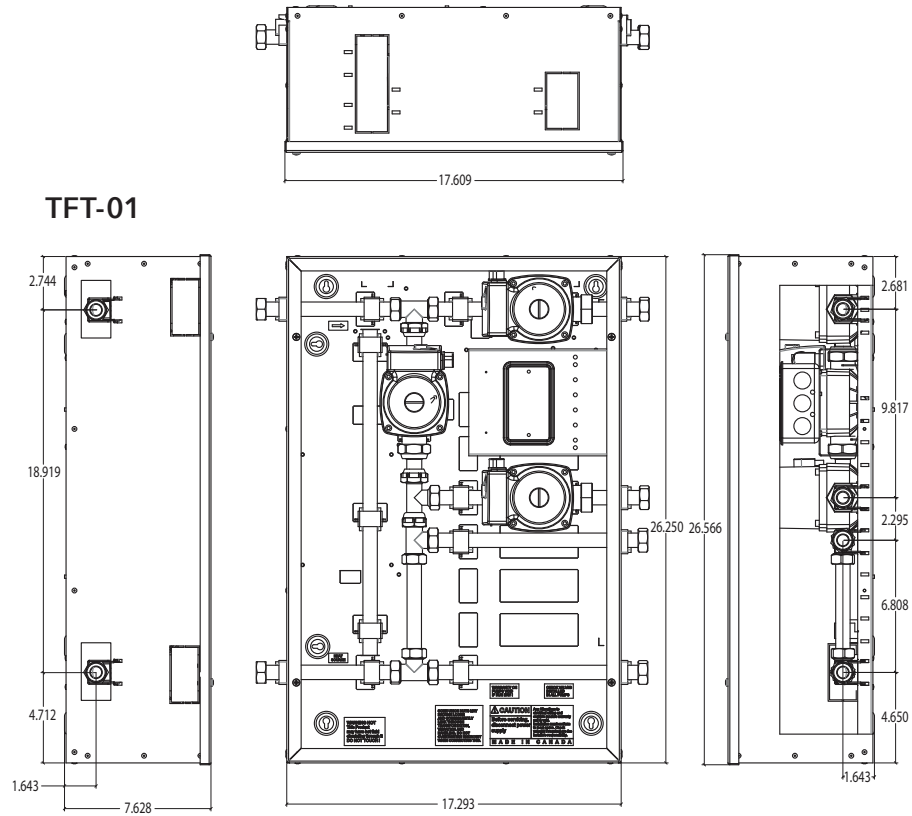

**TFT-02**

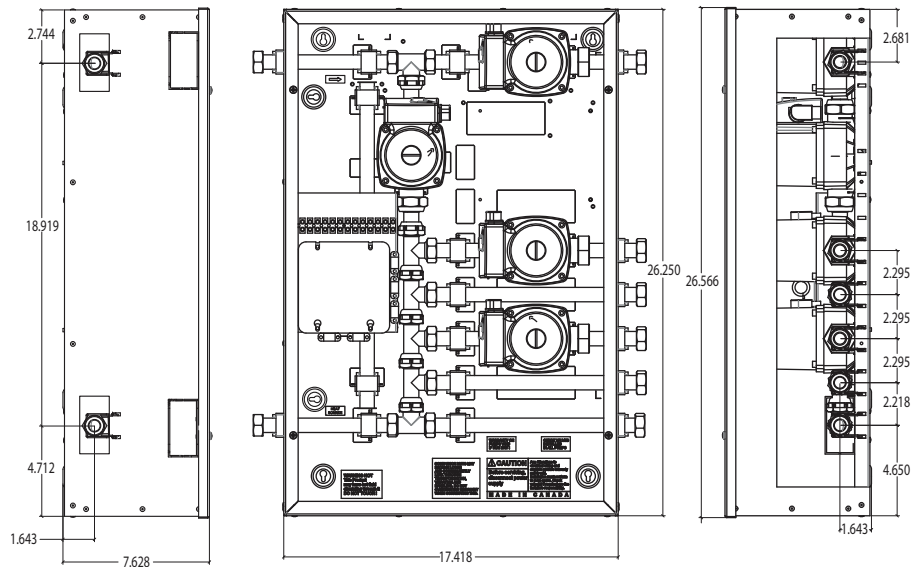

## Panel Component Specifications

### Circulators

The circulators moves the heated fluid through the hydronic system when there is a call for heat from the thermostat.

Specifications:

- The following pump curves apply.

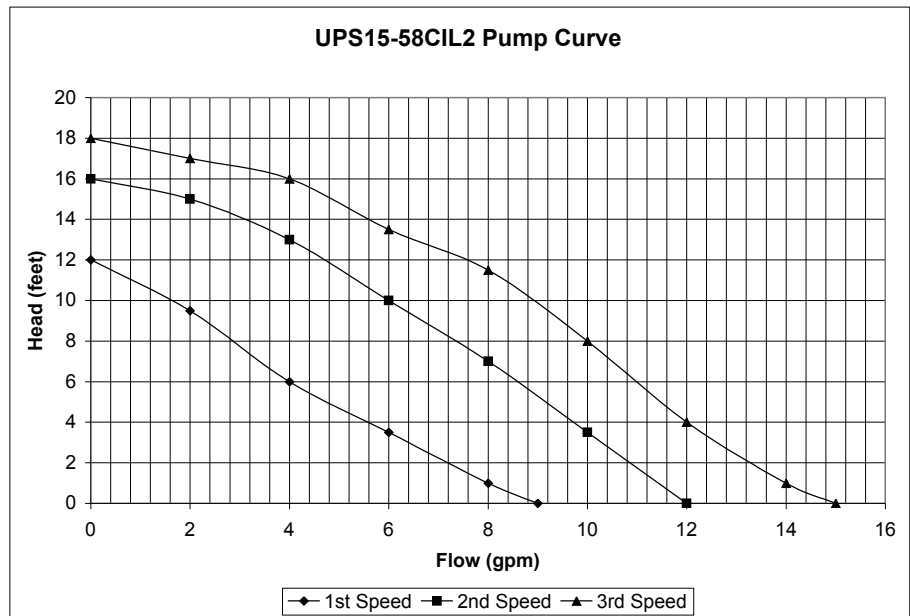
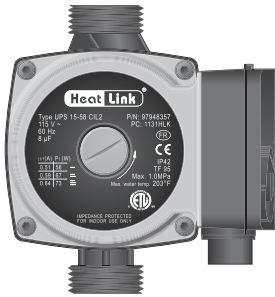



## Mounting

Prior to mounting the panel, ensure the wall is capable of supporting the weight of the panel. Ensure that a 120V receptacle is within reach of the plug-in transformer. The panel can be mounted right of the boiler

### Mounting Directly Below the Boiler

- Step 1** Level the panel and align it with the boiler so that there is sufficient space to pipe the supply and return. See boiler instructions for details on how to pipe supply and return.
- Step 2** Secure the panel in place with supplied screws.

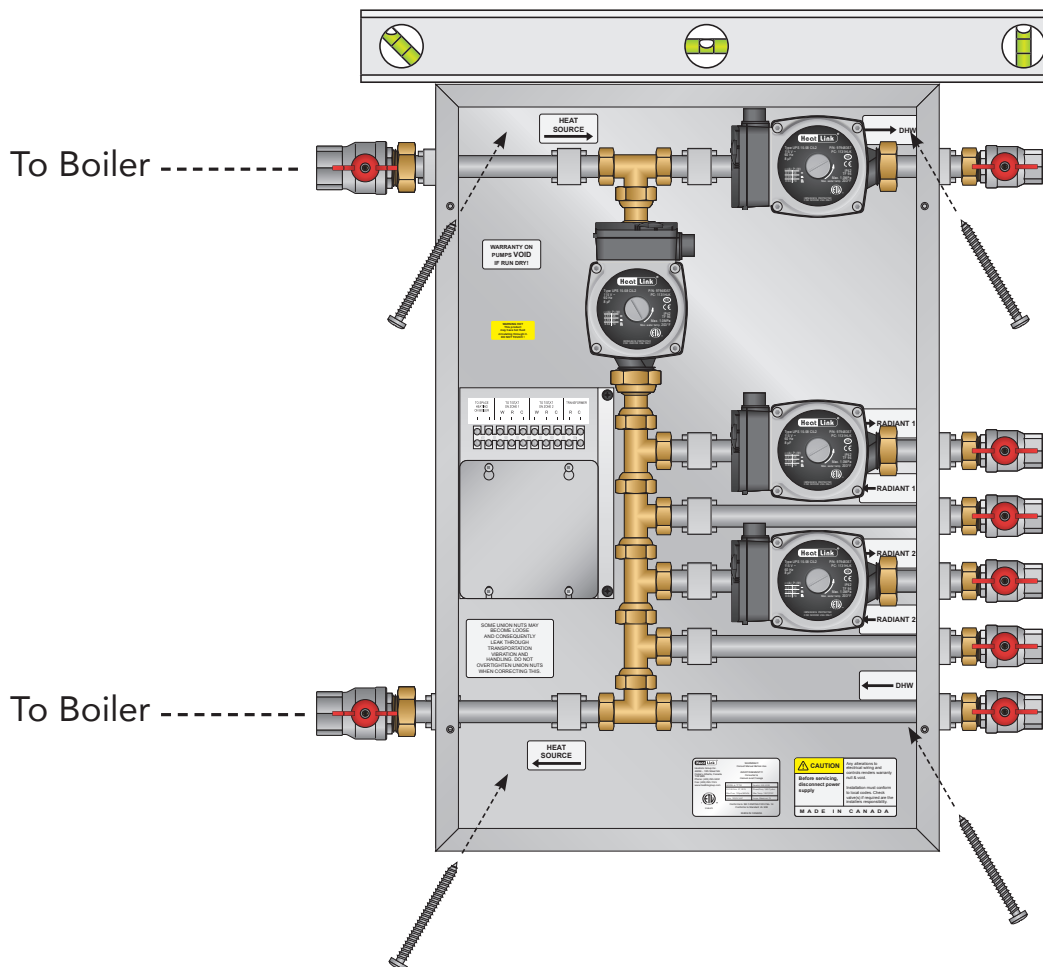

### Piping Hookup

With the panel hooked up to the boiler (see page 8) you can now make the rest of the connections. The supplied washers (B) must be used for all panel connections - do not overtighten the panel connections, as this will damage the rubber washers.

You will need 2 x 30mm, or large adjustable (Crescent®) or smooth jaw pipe wrenches to tighten fittings.

**Step 1** Connect the valves (C) to copper pipe or PEX tubing using a MNPT fitting or adapter (D), and then to the panel pipework.

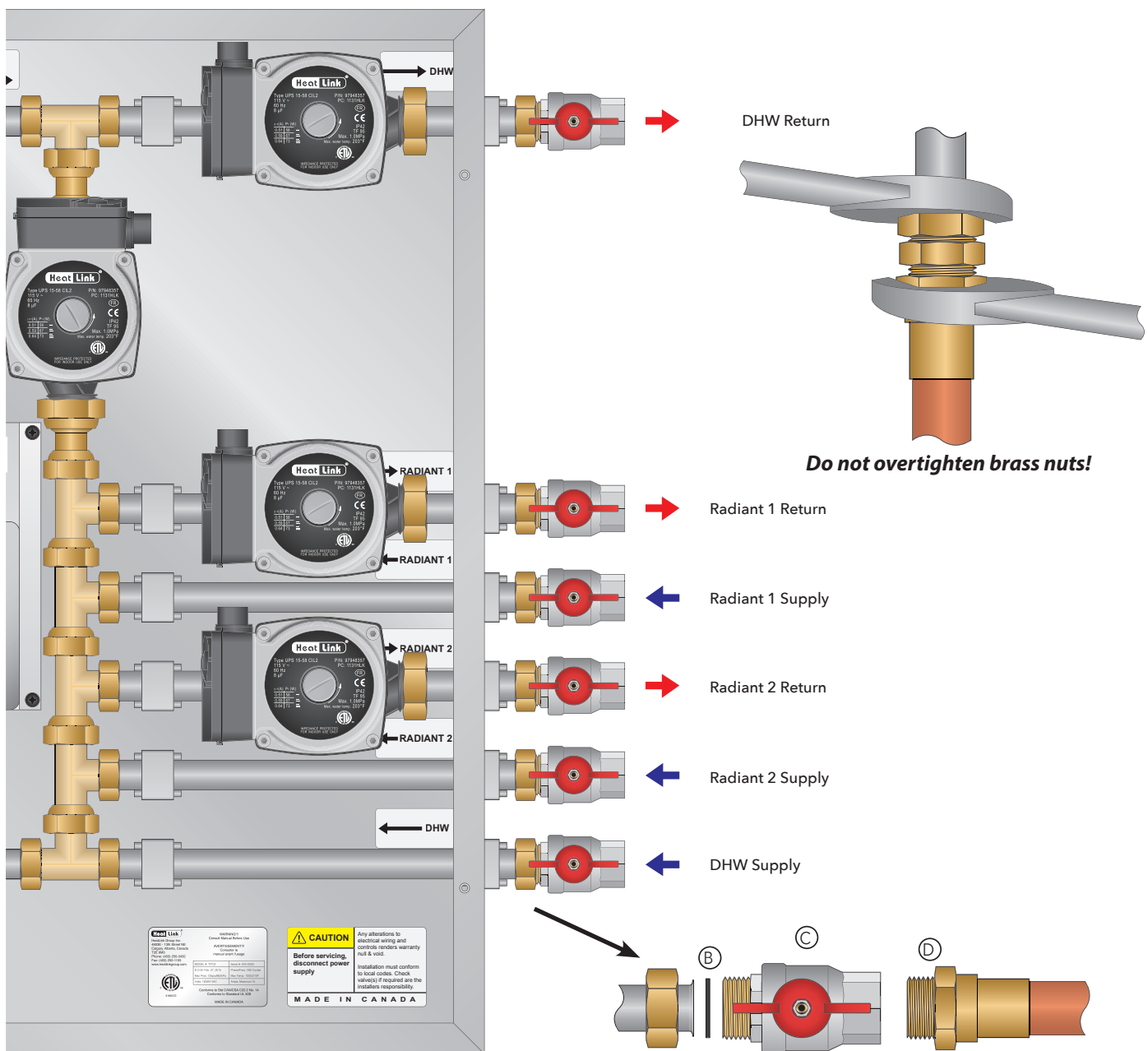

Note: Use precautions when soldering or applying heat within 16" of the panel.

### Fill and Purge

The following steps are recommended in order to fill the panel with water and purge entrained air once piping is completed, and before activation of the panel.

**Note:** Additional purging steps may be required for the rest of the hydronic system.

**Step 1** Ensure the panel is not plugged in.

**Step 2** Fully close valves (A), (B), (C), (D), (E), and (F).

**Step 3** Attach a fill hose and a purge hose (not included) at the Heating Manifold supplied from valves (B) and (C).

**Step 4** Fill the system.

**Step 5** When the water coming out of the purge hose is free of bubbles fully open valves (B) and (C).

**Step 6** When exiting water from manifold is free of bubbles, close valve (B) and (C).

**Step 7** Repeat for valves (D) & (E).

**Step 8** Repeat for valves (A) & (F), and purge from drain point and indirect tank.

**Step 9** Remove hoses from manifolds and fully open valves (A), (B), (C), (D), (E), and (F).

**Step 10** Vent all pumps (use a large flat head screwdriver to avoid damage to vents) before starting the system.

**Step 11** Check for leaks at connections. If any leaks are found, use a back-up wrench and carefully tighten until leak stops. Do not overtighten.

**Step 12** Pressurize system to the required operating pressure.

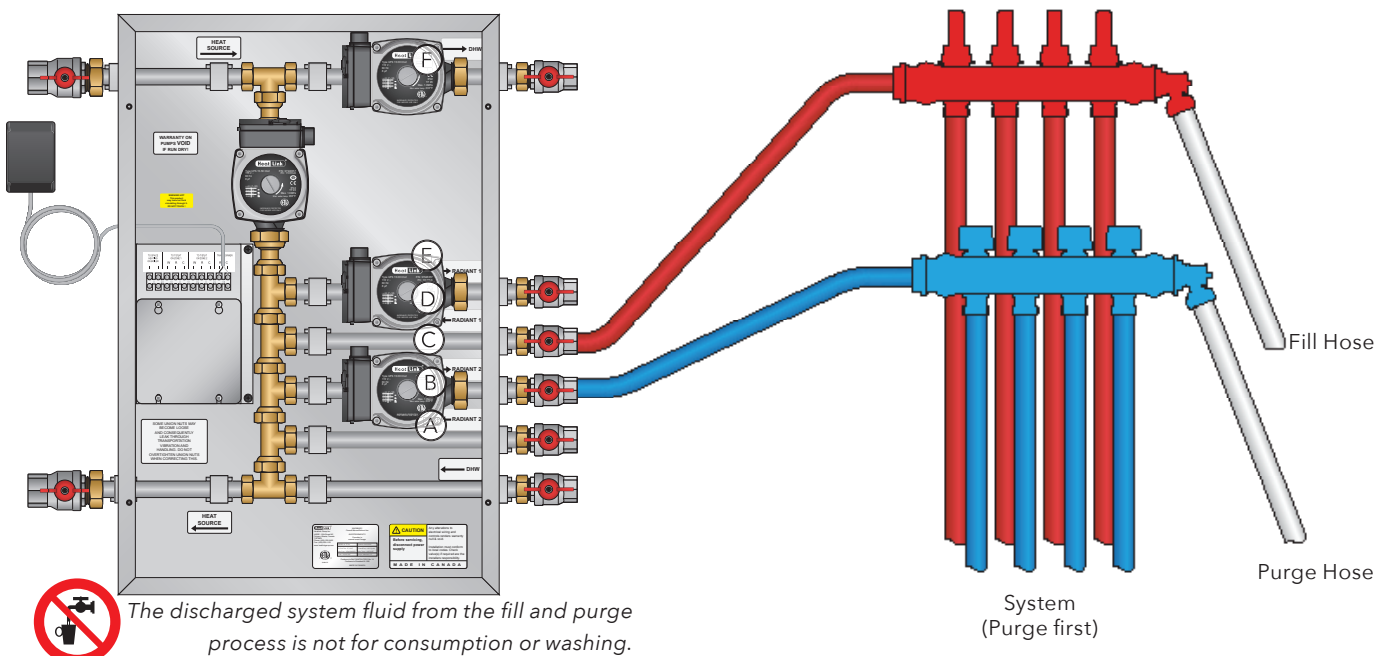

## TFT-01 Panel Control Sequence & Wiring

### Sequence of Operations – Space Heating

With 110V connections made to the boiler, a heat demand from the room thermostat (2) will send a heating demand to the boiler. The boiler will turn on the Primary (3) circulator and Radiant (4) circulator. The supply water temp is determined by the boiler. When the heat demand is removed, the Radiant (4) and Primary (3) circulators will stop.

### Sequence of Operations – DHW

With a demand from the DHW aquastat to the boiler, the boiler will turn on the DHW (6) circulator and disable the Primary (3) and Radiant (4) circulator (if running) and change the supply water temp according to its settings. When the DHW demand is removed, the DHW (6) circulator will continue to run for as long as the boiler control requires.



- All wiring should be done by a qualified electrician and should meet local codes and jurisdictions.

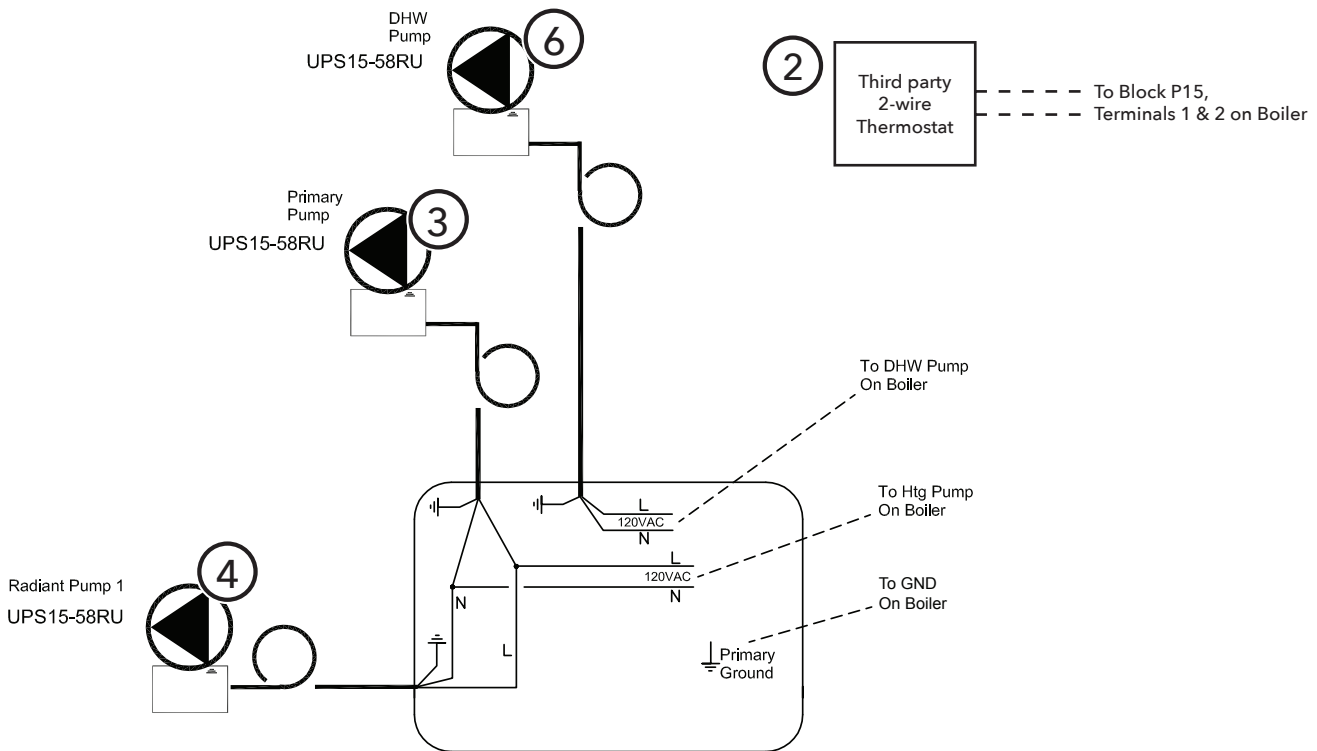

Note: HeatLink® 3-wire thermostats require the use of a relay, StatLink® 6 Zone Base Module, or Actuator with End Switch.

----- Field Wiring  
 \_\_\_\_\_ Factory Wiring

### TFT-02 Panel Control Sequence & Wiring

#### Sequence of Operations – Space Heating

With 110V connections made to the boiler and the transformer (1) plugged in, a heat demand from either room thermostat (2) will close its corresponding relay in the panel and send a heating demand to the boiler. The boiler will turn on the Primary (3) circulator and appropriate Radiant (4)(5) circulator. The supply water temp is determined by the boiler. When the heat demand is removed, the Radiant (4)(5) circulators will stop and the Primary (3) circulator will continue to run for as long as the boiler control requires.

#### Sequence of Operations – DHW

With a demand from the DHW aquastat to the boiler, the boiler will turn on the DHW (6) circulator and disable the Primary (3) and Radiant (4)(5) circulators (if running) and change the supply water temp according to its settings. When the DHW demand is removed, the DHW (6) circulator will continue to run for as long as the boiler control requires.



- 24V low voltage power may be supplied to the thermostat. Wiring to the terminal strip requires 18 gauge 4 wire.
- All wiring should be done by a qualified electrician and should meet local codes and jurisdictions.
- See next page for thermostat wiring.

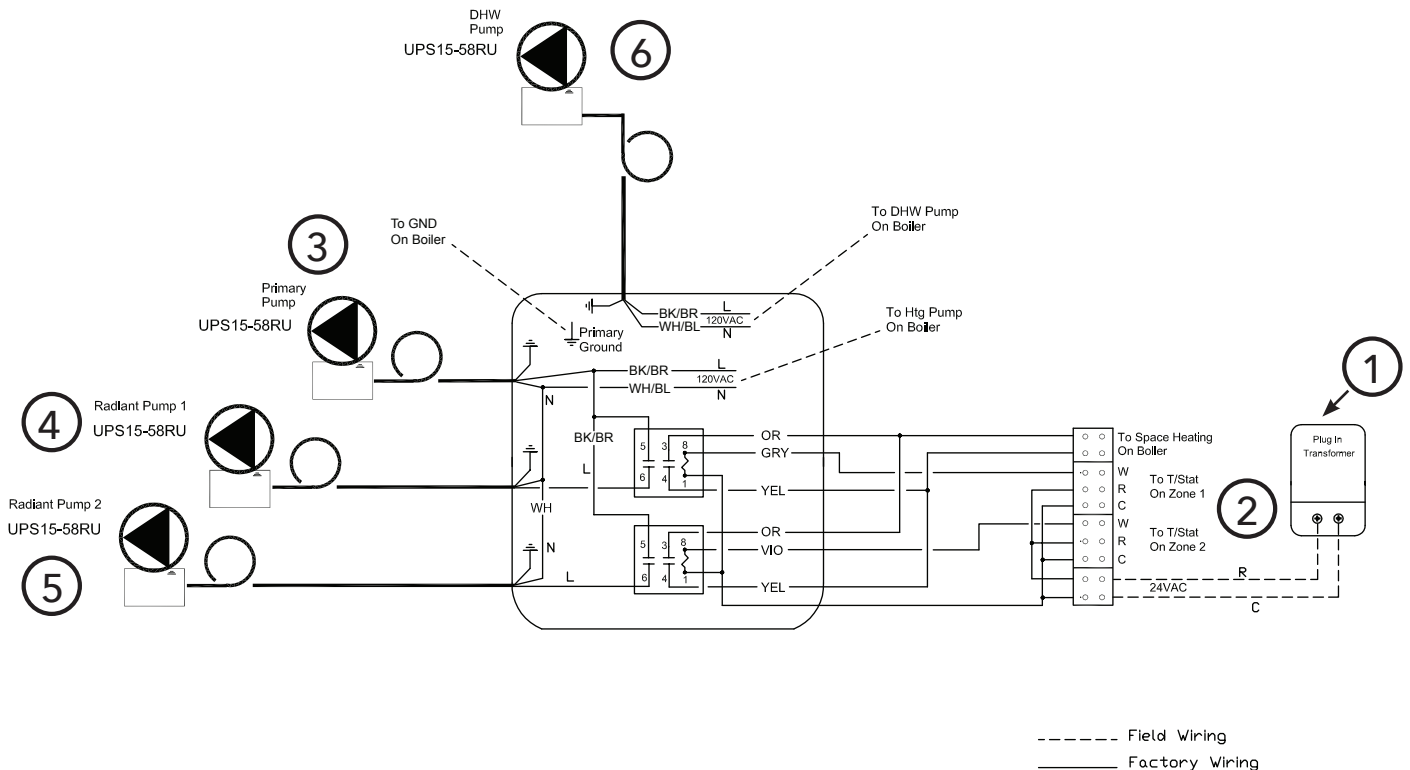

## Troubleshooting

Problem	Check / Verify	Possible Cause
<b>Low Temperature Within Room</b>	Wiring from heat source to panel.	Check that the wiring is done properly. Consult qualified electrician prior to alteration of wiring between heat source and panel.
	Output of heat source is unable to meet demand of heating system.	Compare output of heat source to the requirements of the heating system.
	Circulator is not on during a call for heat. (Use a stethoscope or similar device to verify)	The circulator may be defective.
	When zone valves are installed outside the panel a qualified electrician should verify 24V power is supplied to the actuator.	The 24V transformer may have failed. Any zone valves must be opened manually to avoid dead-heading of the circulator.
<b>High Temperature Within Room</b>	Installed electronic actuators remain open.	An obstruction inside the zone valve is not allowing the actuator to fully close or there is still a call for heat.

## Maintenance

Yearly maintenance should be done on the panel prior to each heating season to ensure the efficient and accurate operation of the panel.

Complete the following check list:

- Raise all thermostats to cause a call for heat within the system. Verify that the circulator starts, via a stethoscope or similar device.
- Confirm that the Auxiliary Contacts close.
- If applicable, verify that each zone valve opens during the call for heat – the actuator should be warm to the touch, the LED will light up (on 5620x models) and the white indicator should rise from the top of the actuator.
- Return all thermostats to a desirable setting.

You are now ready for another heating season with HeatLink.

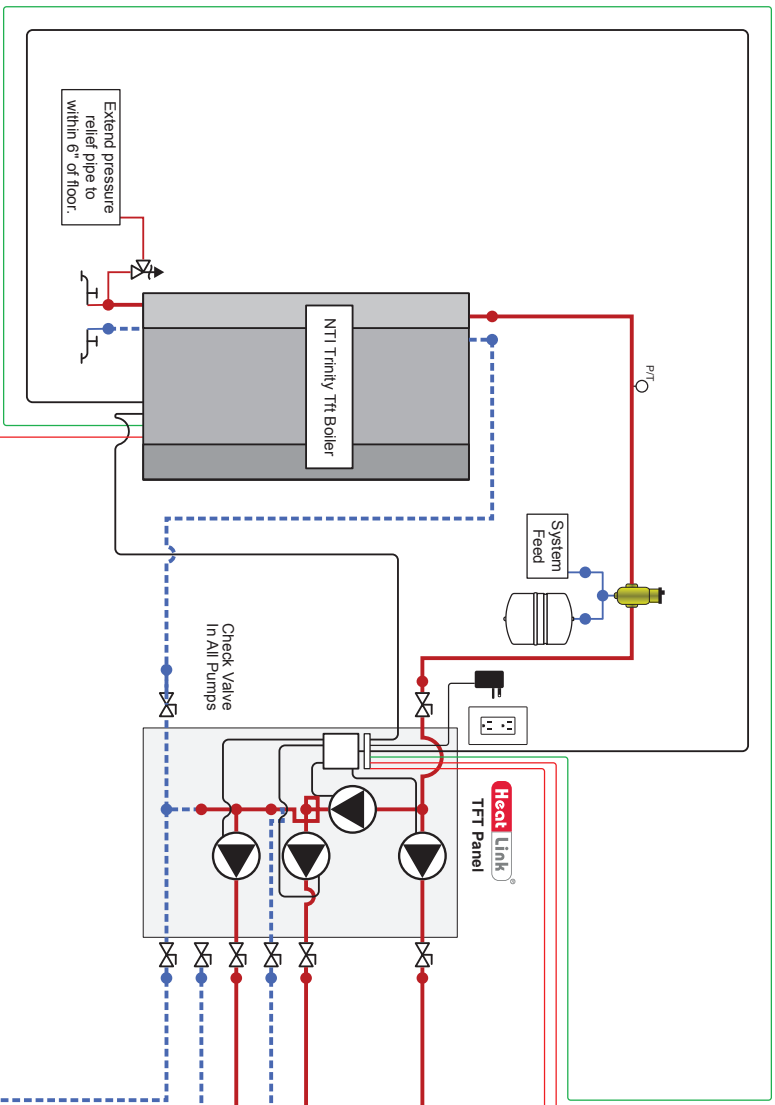

**Heat Link**  
 www.heatlink.com  
 1-866-661-5332

- Notes:**
- Drawings are for HeatLink suggested system layout only. User must determine if system layout will work for their particular application.
  - Air vents, expansion tanks, pressure relief valves, etc. for heat source as per local codes.
  - Use isolation ball valves for all circuits and components.
  - Local codes, regulations, and authorities have final jurisdiction.

Heat Source: NTI Trinity Tft Boiler  
 Panel(s): Tft02  
 Heat Load(s): IFHWH, Radiant Heating  
 Date: 2017-05-11

Schematic #: **SCH-TFT-M002**  
 Rough-in wiring see: SCH-MRIB-R001  
 Wiring detail see: SCH-TFT-E002



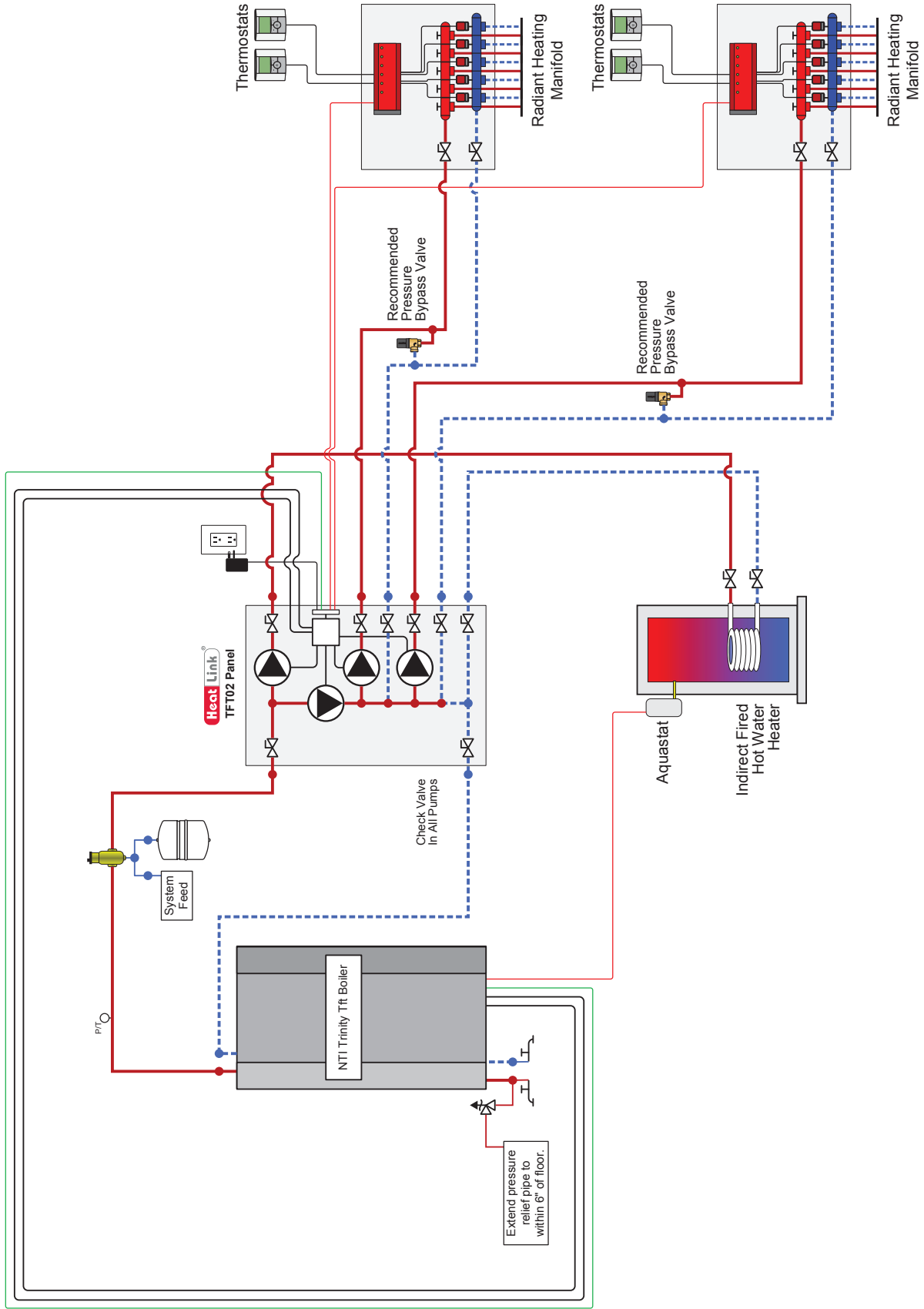

- Notes:**
- Drawings are for HeatLink suggested system layout only! User must determine if system layout will work for their particular application.
  - Air vents, expansion tanks, pressure relief valves, etc. for heat source as per local codes.
  - Use isolation ball valves for all circuits and components.
  - Local codes, regulations, and authorities have final jurisdiction.

Heat Source: NTI Trinity Tft Boiler  
 Panel(s): TF T02  
 Heat Load(s): IFHWH, Radiant Heating  
 Date: 2015-02-04

Schematic #: SCH-TFT-M004  
 Rough-in wiring see: SCH-MRIB-R002  
 Wiring detail see: SCH-TFT-E004

**Heat Link<sup>®</sup>**  
 www.heatlink.com  
 1-866-661-5332

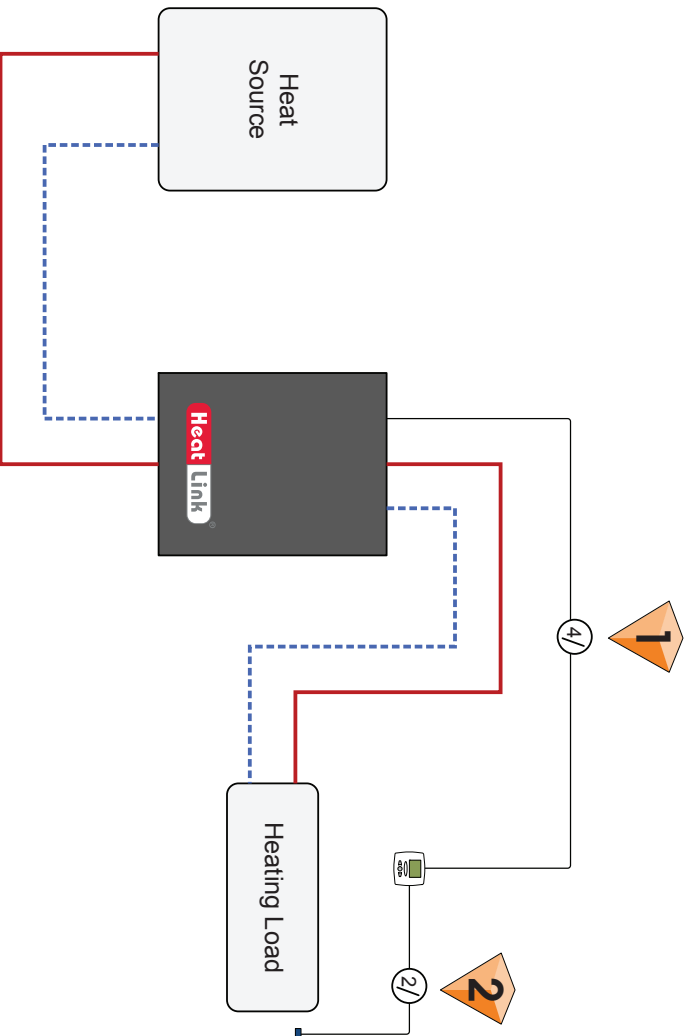

**1 Room Thermostat**  
Standard 4-wire to be run from thermostat to mechanical room.



**2 Floor Sensor (optional)**  
Standard 2-wire to be run from thermostat to floor sensor.



www.heatlinkgroup.com  
1-866-661-5332

- Notes:**
- Drawings are for Heatlink suggested electrical schematics only. User must determine if electrical schematic will work for their particular application. User must also confirm all Heatlink schematics with manufacturer schematics of each particular control chosen.
  - In all cases, manufacturer equipment schematics will take precedence over Heatlink electrical schematics.
  - Local codes, regulations, and authorities have final jurisdiction.

**Application:** Rough-in Wiring for One Zone Heating  
**Date:** 2012-10-19

**Schematic #:** SCH-MRIB-R001

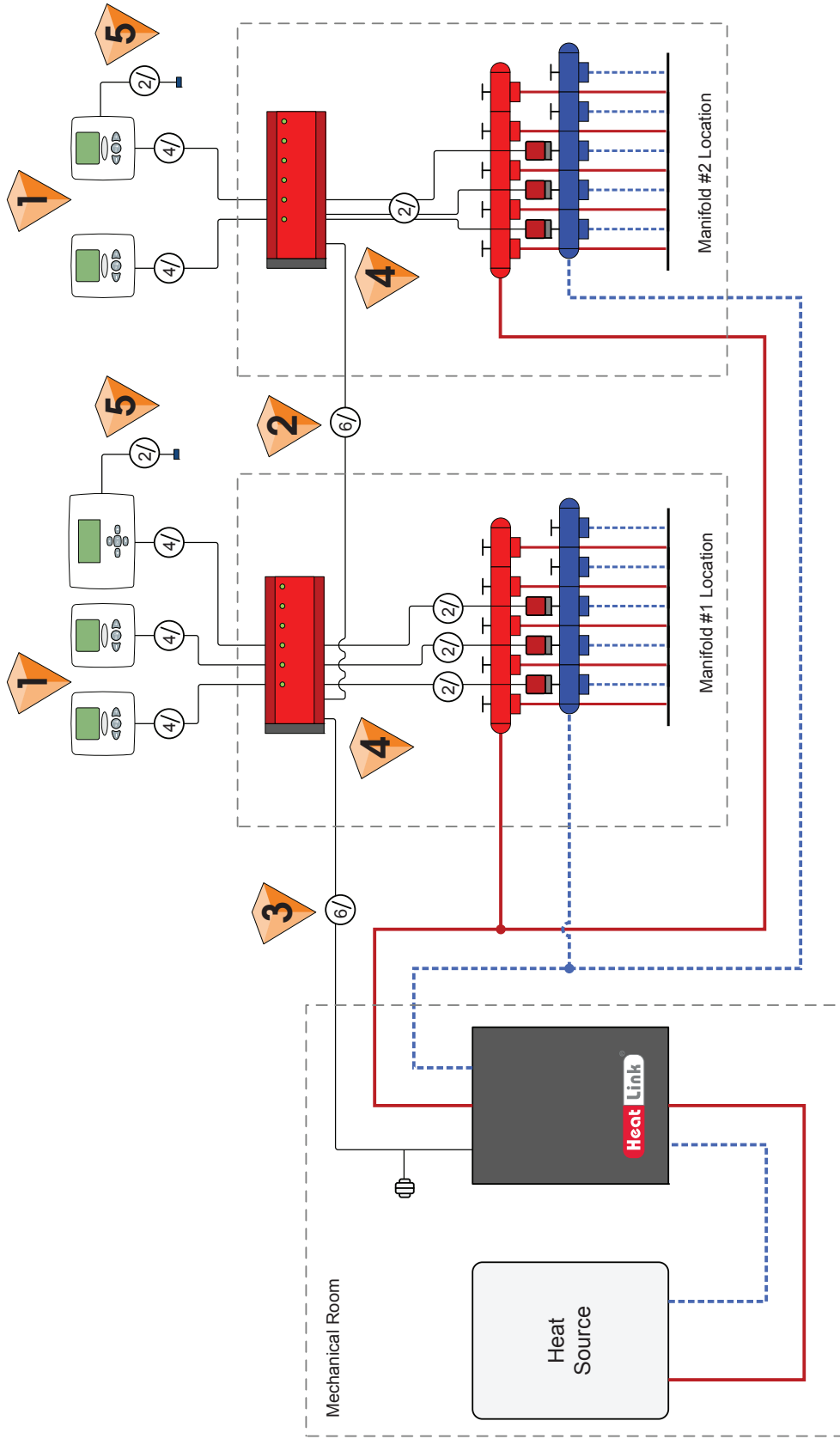

- 1 Room Thermostats**  
Standard 4-wire to be run from each zone back to the corresponding manifold location.
- 2 6-wire Jumper**  
6-wire to be run between each manifold location. This allows for the transfer of the clock signal, heat demand information, and power from module to module.
- 3 6-wire Jumper**  
6-wire to be run from the last manifold location to the mechanical room. This allows for the transfer of the clock signal, heat demand information, and power.
- 4 Optional**  
Allow for 110V power source to a 24V transformer at each manifold location instead of supplying 24V power from the mechanical room.
- 5 Floor Sensor (optional)**  
Standard 2-wire to be run from thermostat to floor sensor.

**Heat Link**  
www.heatlinkgroup.com  
1-866-661-5332

**Notes:**

- Drawings are for HeatLink suggested electrical schematics only! User must determine if electrical schematics will work for their particular application. User must also confirm all HeatLink schematics with manufacturer schematics of each particular control chosen.
- In all cases manufacturer equipment schematics will take precedence over HeatLink electrical schematics.
- Local codes, regulations, and authorities have final jurisdiction.

**Application:** Rough-in Wiring for Multiple Zone Heating with StatLink

**Date:** 2012-10-19

**Schematic #:** SCH-MRIB-R002

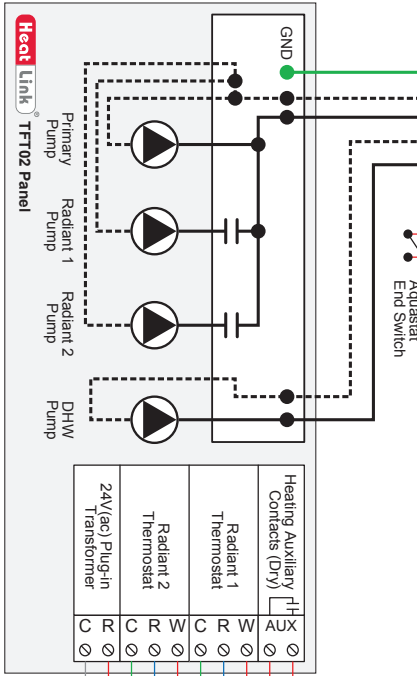
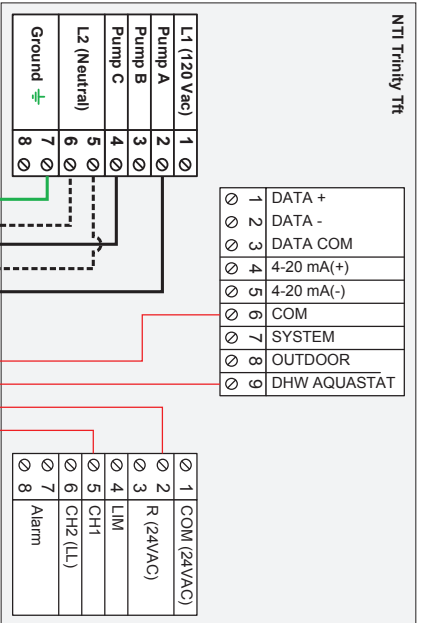

Heating Auxiliary Contacts (Dry)	TH	X	Ø
Radiant 1 Thermostat	R	W	Ø
Radiant 2 Thermostat	R	W	Ø
24V/60W Plug-in Transformer	Ø	Ø	Ø

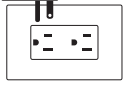
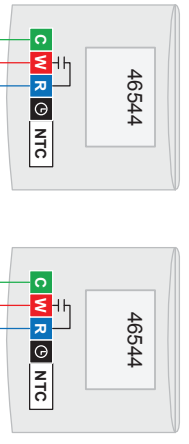

**Notes:**

- Drawings are for HeatLink suggested electrical schematics only! User must determine if electrical schematic will work for their particular application. User must also confirm all HeatLink schematics with manufacturer schematics of each particular control chosen.
- In all cases manufacturer equipment schematics will take precedence over HeatLink electrical schematics.
- Local codes, regulations, and authorities have final jurisdiction.

**Application:** Radiant Heating and Indirect Fired Hot Water Heater

**Schematic #:** SCH-TFT-E002

*Rough-in wiring see:*



www.heatlink.com  
1-866-661-5332

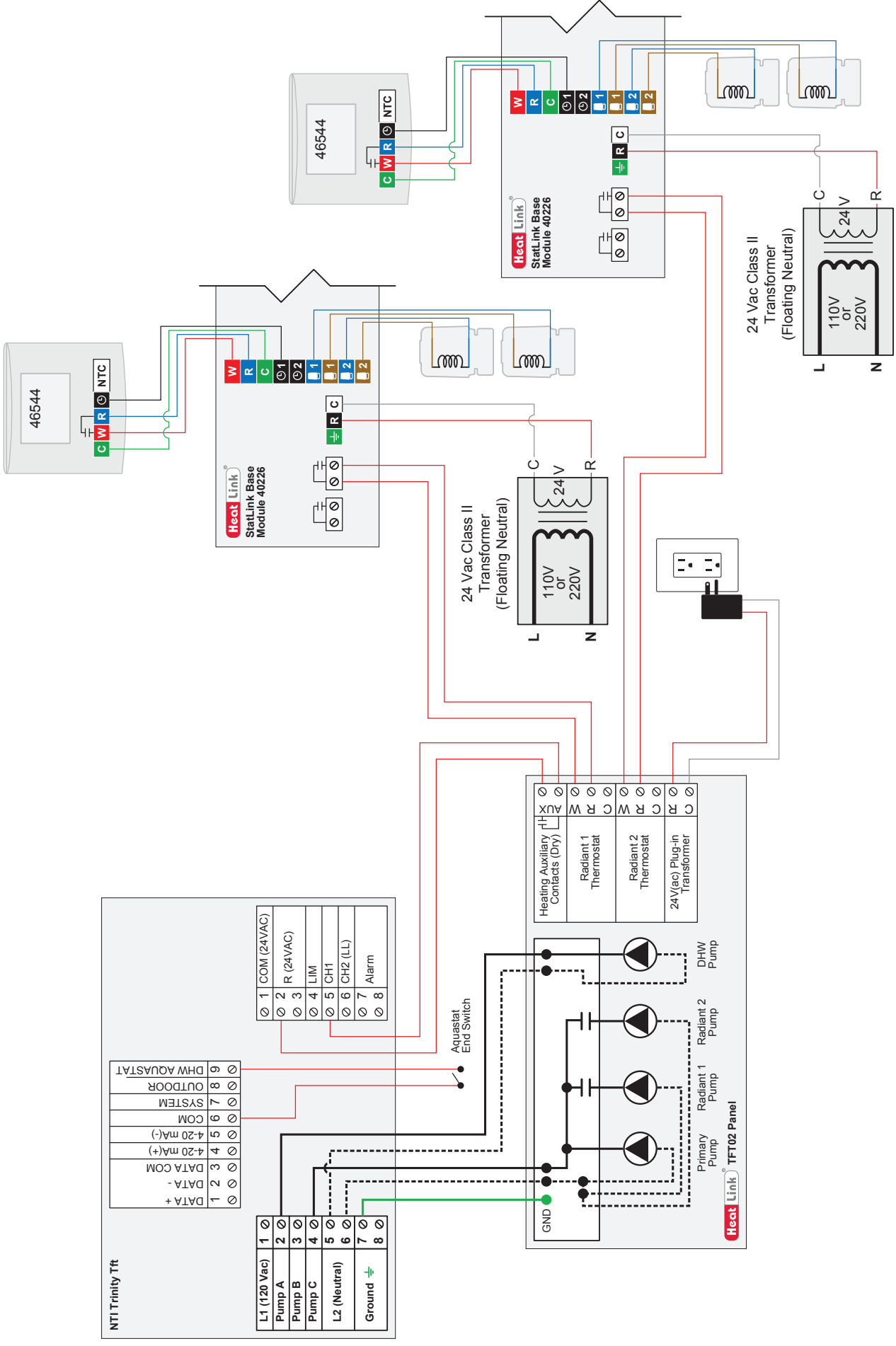

**Schematic #:** SCH-TFT-E004  
**Rough-in wiring see:** SCH-MRIB-R002

**Application:** Radiant Heating and Indirect Fired Hot Water Heater  
**Date:** 2015-02-04

**Notes:**

- Drawings are for HeatLink suggested electrical schematics only! User must determine if electrical schematic will work for their particular application. User must also confirm all HeatLink schematics with manufacturer schematics of each particular control chosen.
- In all cases manufacturer equipment schematics will take precedence over HeatLink electrical schematics.
- Local codes, regulations, and authorities have final jurisdiction.

**HeatLink**  
 www.heatlink.com  
 1-866-661-5332

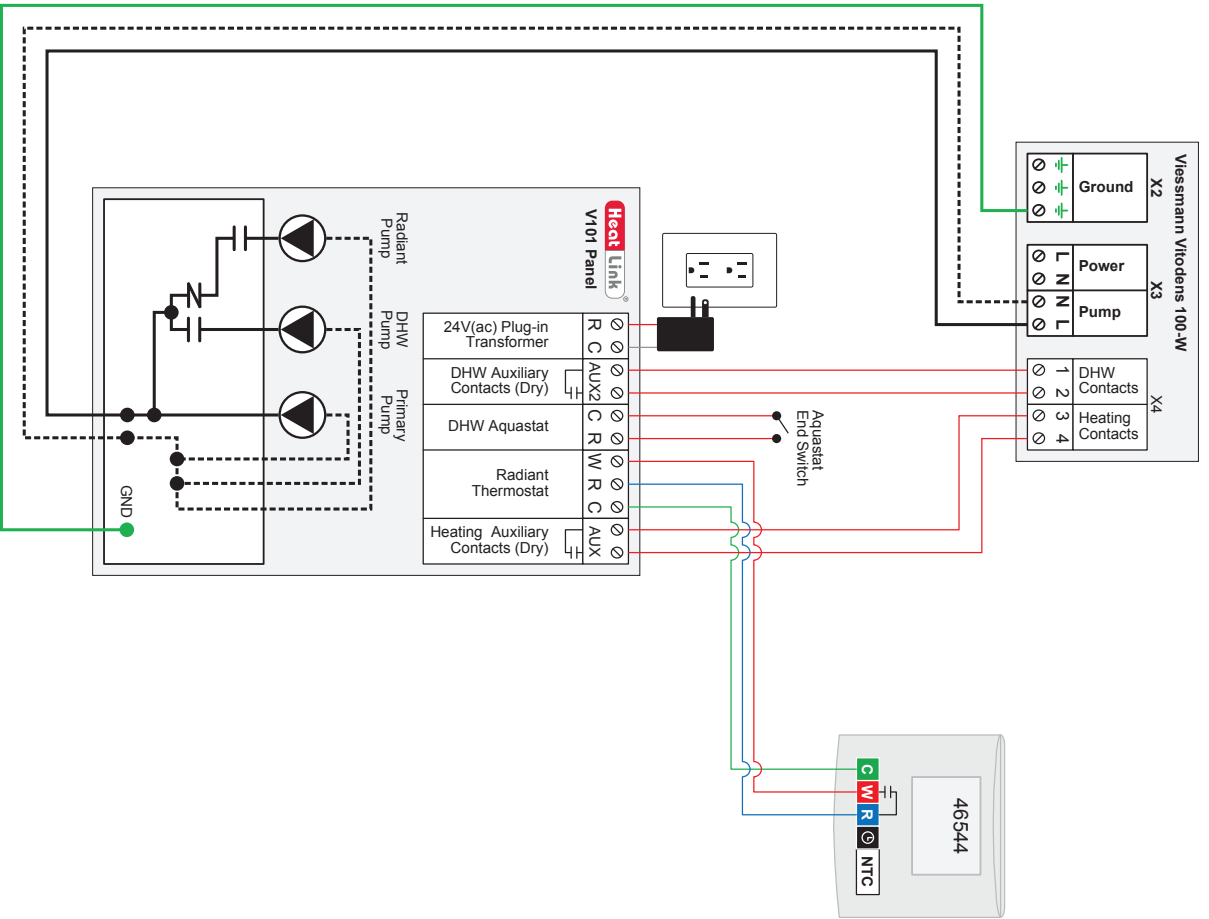

**Heat Link**  
 www.heatlink.com  
 1-866-661-5332

**Notes:**

- Drawings are for HeatLink suggested electrical schematics only! User must determine if electrical schematic will work for their particular application. User must also confirm all HeatLink schematics with manufacturer schematics of each particular control chosen.
- In all cases manufacturer equipment schematics will take precedence over HeatLink electrical schematics.
- Local codes, regulations, and authorities have final jurisdiction.

**Application:** Radiant Heating and Indirect Fired Hot Water Heater  
**Date:** 2014-08-21

**Schematic #:** SCH-V100-E001  
**Rough-in wiring see:** SCH-MRIB-R001



**info@heatlink.com**  
**www.heatlink.com**

*HeatLink, the HeatLink logo, and "Mechanical Room in a Box" logo are either registered trademarks or trademarks of HeatLink Group Inc.*