

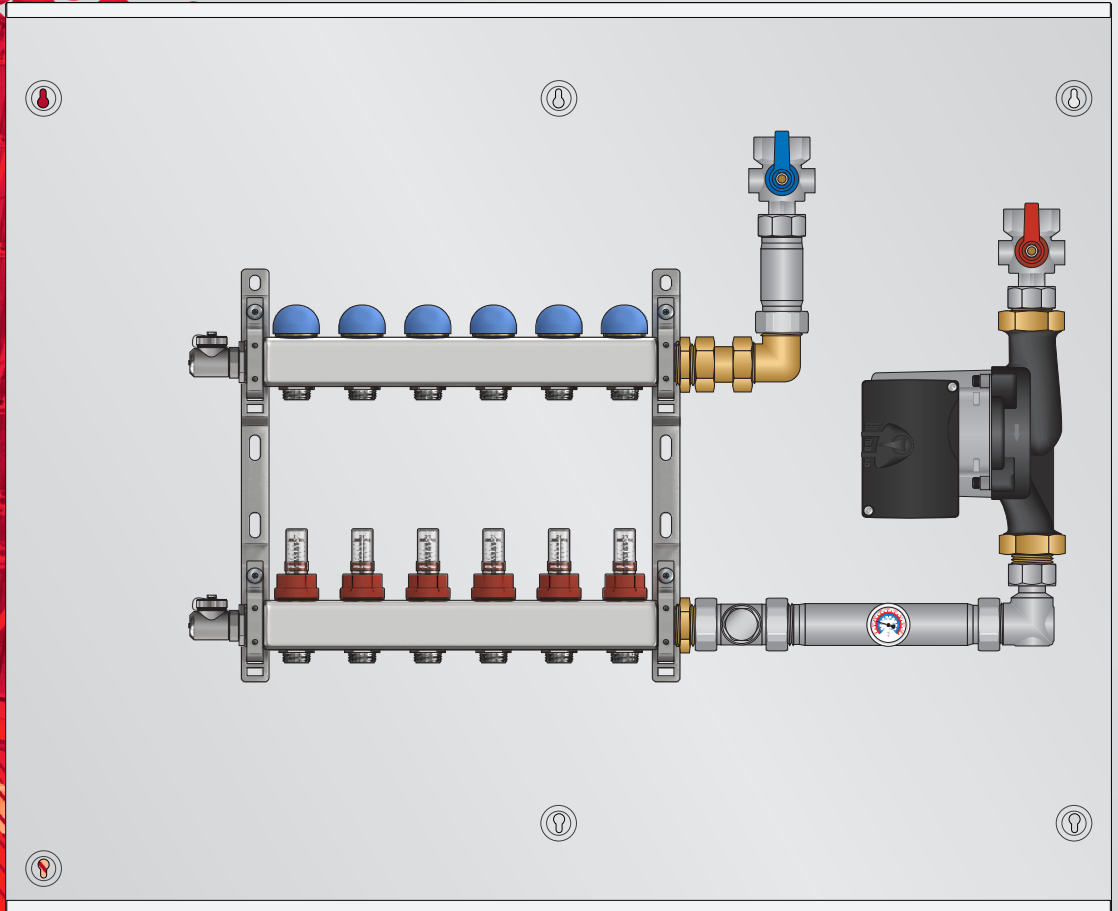

SSP Series

Installation, Operation, and Maintenance Manual



Product Safety Information	2
Warnings	2
Servicing.....	2
Function.....	2
Unpacking	3
Installation Tools Needed	3
Panel Configurations.....	4
Panel Dimensions.....	5
Panel Components (Diagram).....	6
Panel Components Breakdown.....	7
Pump Curves.....	8
Optional Add-Ons.....	9
Panel Mounting - Recessed Enclosure	10
Panel Mounting - Surface Enclosure	11
Piping Hookup.....	12
PEX Tubing to Manifold Connections	13
Fill & Purge	14
Balancing (75100 series with Flow Meters).....	16
Balancing (75200 series High Flow).....	16
75100 Series Friction Head Graph.....	17
75200 Series Friction Head Graph	18
Troubleshooting	19
Maintenance.....	19
Differential piping schematic.....	20

Disclaimer

HeatLink Group Inc. shall not be responsible for errors in its brochures or printed materials. HeatLink Group Inc. reserves the right to alter its products at any time without notice, provided that alterations to products already on order shall not require material changes in specifications previously agreed upon HeatLink Group Inc. and the Purchaser. All trademarks in this material are property of the respective companies. HeatLink and the HeatLink logotype are trademarks of HeatLink Group Inc. All rights reserved.

Product Safety Information

Warnings

The zone control panel is for indoor use only and must be installed by a qualified installer/service technician. This product must be installed and operated in strict accordance with the terms set out in this manual and in accordance with the relevant requirements of the Local Authority Having Jurisdiction. Failure to comply will result in a void of warranty, and may also result in property damage, serious injury, or death.

Servicing

Prior to commencing installation of this panel it is necessary to read and understand all sections of this manual. The symbols below are used throughout this document to ensure proper operation of the panel, and your safety. Please pay attention to these symbols.



Warning
Possible Hazard



Warning
Live Power



Warning
Hot Pipes



Warning
Treated Water



In order to avoid injury or death, switch off the power to the panel prior to inspecting or making connections to the terminal strip.

Function

This zone control panel can provide mixing, distribution, and zoning for a wide variety of hydronic heating applications.

The effectiveness of the system is dependant on the system being designed and installed correctly. Proper consideration of factors such as BTU loads, outdoor design temperature, indoor design temperature, room set-point temperature(s), differential fluid temperatures, head loss, flow rates, and transfer capacities of the heat emitters is critical.

Once these factors have been considered and the system requirements determined, these can then be evaluated and compared to the panel capabilities.

Note: This panel does not regulate or monitor the operating safety limit temperatures of the fluid leaving the heat source.

Unpacking

- Step 1** Examine carton for any damage that may have occurred during shipping. If damage is visible notify your courier and supplier immediately.
- Step 2** Open the carton by cutting the straps and removing the lid.
- Step 3** Remove the cardboard spacers from the carton, then remove the panel from the carton. Lift the panel by the enclosure, not the cover.
- Step 4** Remove the cover from the panel by unlocking the coin/screwdriver locks. Lift the top of the cover upwards to disengage the tongues from the slots at the bottom of the panel and then pull the cover off.

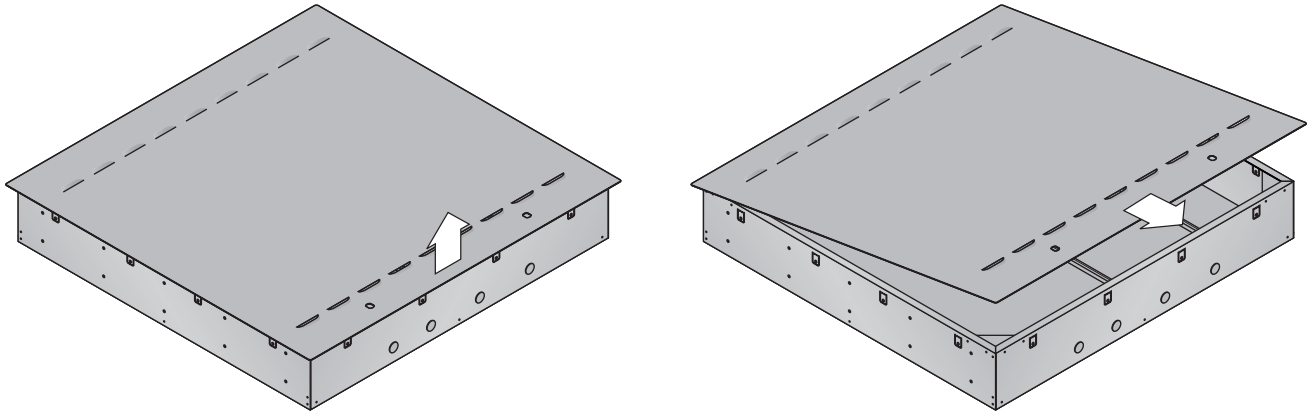

Installation Tools Needed

- Level
- Screwdriver or power drill
- Flat head bit
- Phillips head bit # 2
- 2 adjustable wrenches (or 2 × 30mm wrenches)

Panel Configurations

SSP panels are available in the mechanical configurations illustrated below. SSP panels are available with 4, 6, 8, 10, or 12 loop manifolds in a surface mount recessed cabinet.

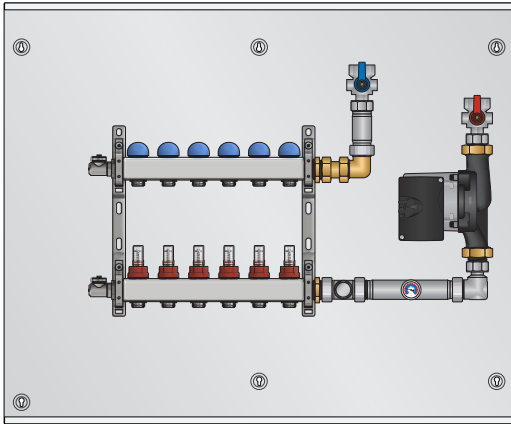

SSPLx10xT - Large (26-99) pump, mixing valve, 76100 manifold with flow meters (shown with 6 loops), top feed.

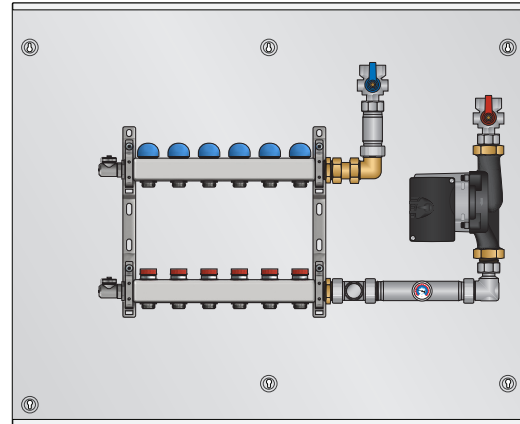

SSPLx20xT - Large (26-99) pump, mixing valve, 76200 high flow manifold (shown with 6 loops), top feed.

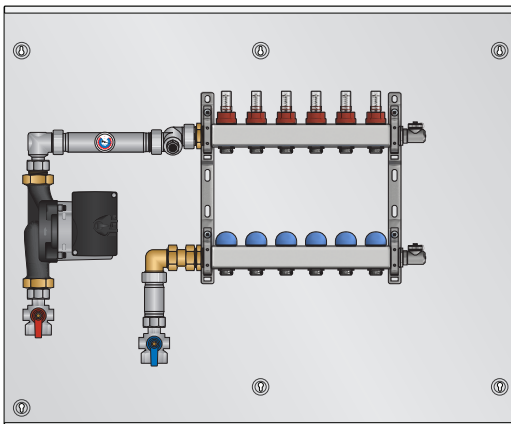

SSPLx10xB - Large (26-99) pump, mixing valve, 76100 manifold with flow meters (shown with 6 loops), bottom feed.

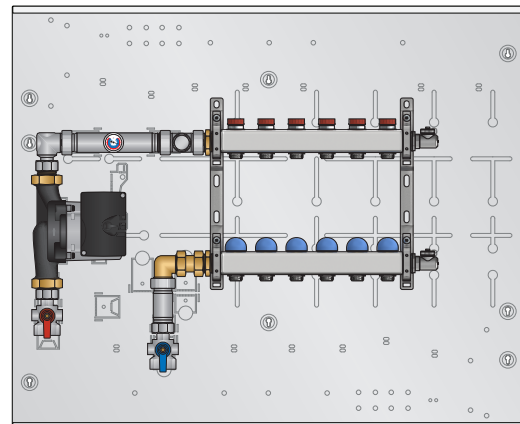

SSPLx20xB - Large (26-99) pump, mixing valve, 76200 high flow manifold (shown with 6 loops), bottom feed.

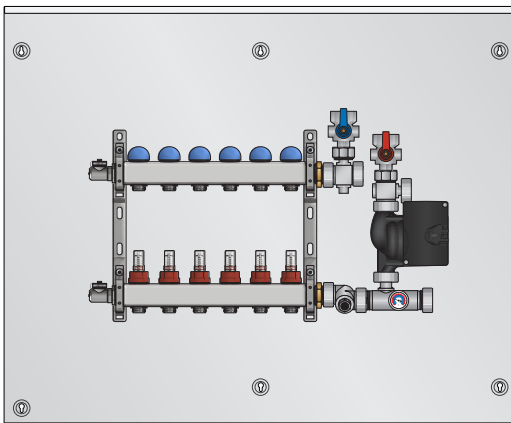

SSPSx10xT - Small (15-58) pump, 3-way mixing valve, 76100 manifold with flow meters (shown with 6 loops), top feed.

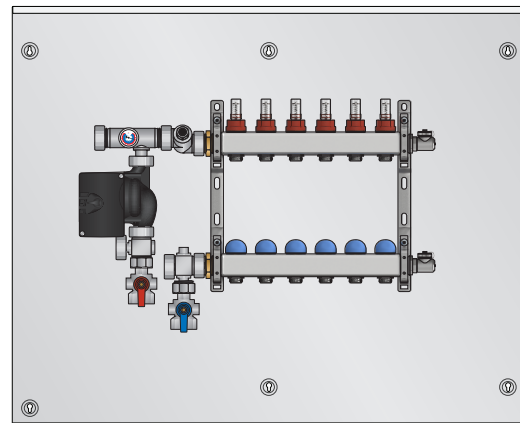

SSPSx10xB - Small (15-58) pump, mixing valve, 76100 manifold with flow meters (shown with 6 loops), bottom feed.

Panel Dimensions

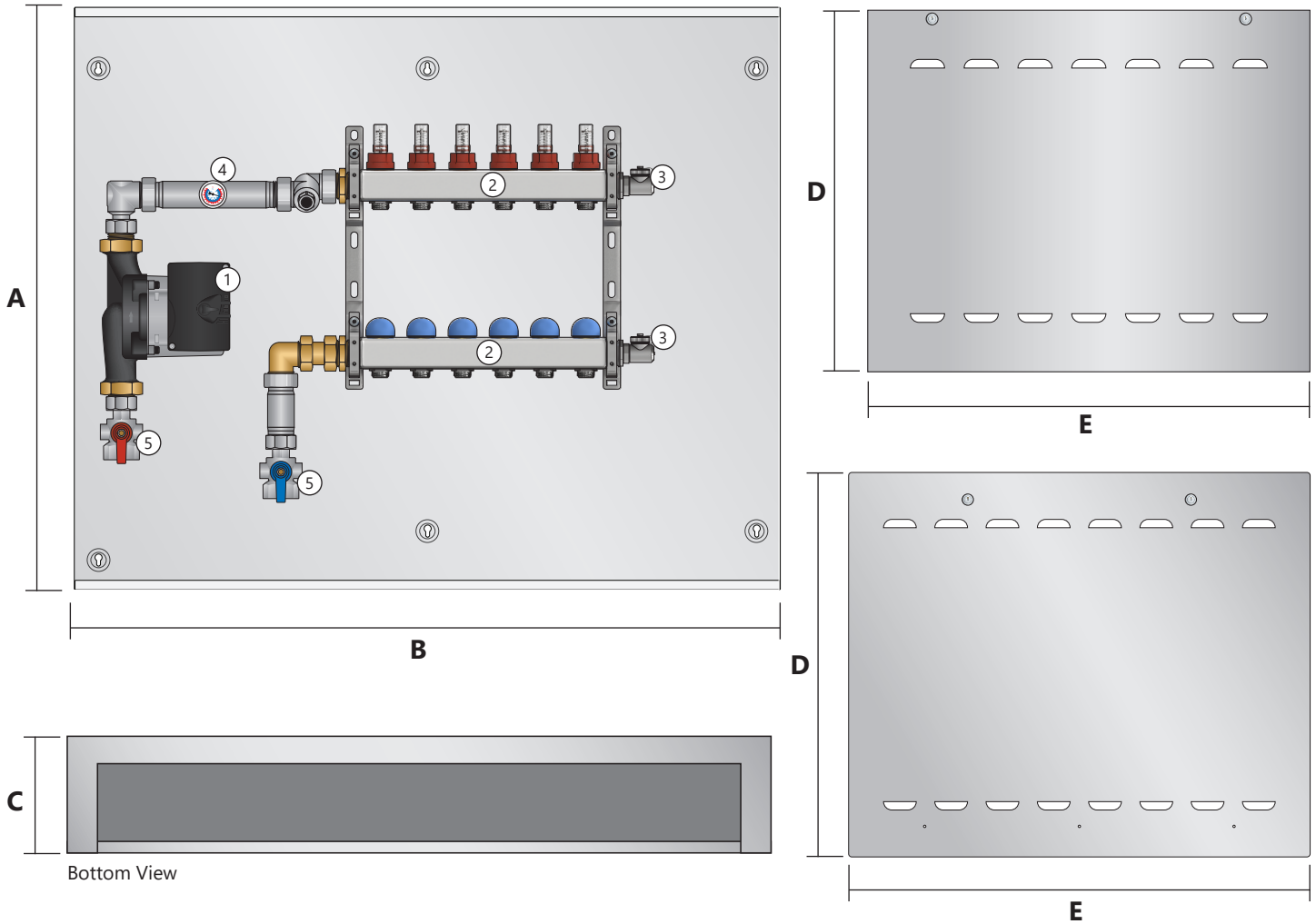

# of Loops	Enclosure Dimensions			Cover Dimensions (Recessed)		Cover Dimensions (Surface)		# of Locks
	A	B	C	D	E	F	G	
4	34-1/2"	28-1/2"	5-7/8"	36"	30"	32-7/8"	26.9"	2
6	(876 mm)	(724 mm)	(149 mm)	(915 mm)	(762 mm)	(835 mm)	(683 mm)	
8	42-1/2"	28-1/2"	5-7/8"	44"	30"	40-7/8"	26.9"	2
10	(1080 mm)	(724 mm)	(149 mm)	(1118 mm)	(762 mm)	(1038 mm)	(683 mm)	
12	46-1/2"	28-1/2"	5-7/8"	48"	30"	44-7/8" (1140 mm)	26.9" (683 mm)	3

Panel Components (Diagram)

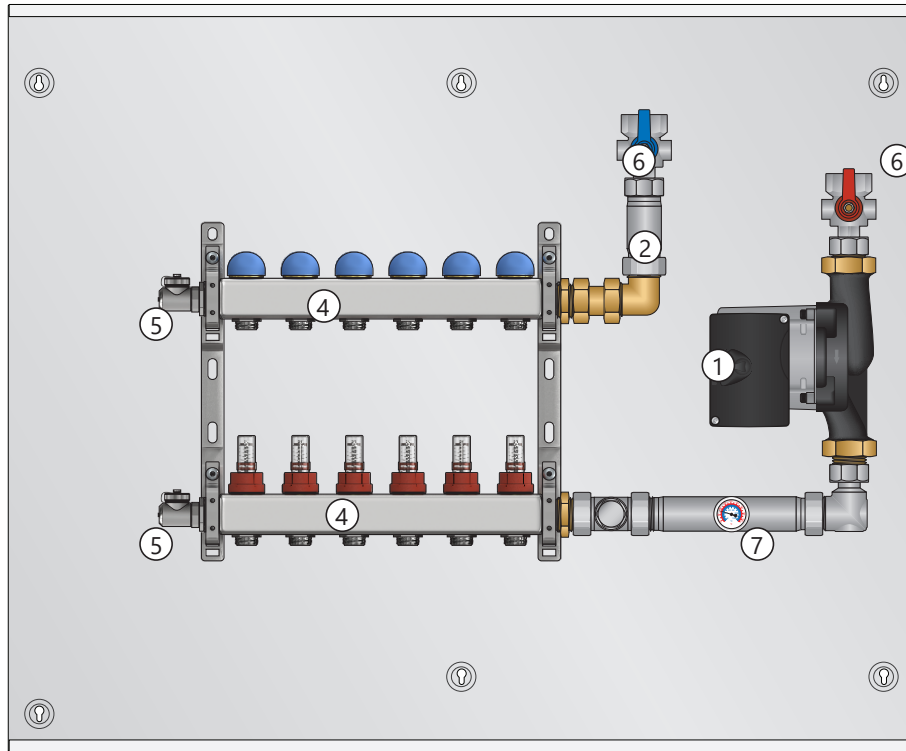

SSPLx106T shown

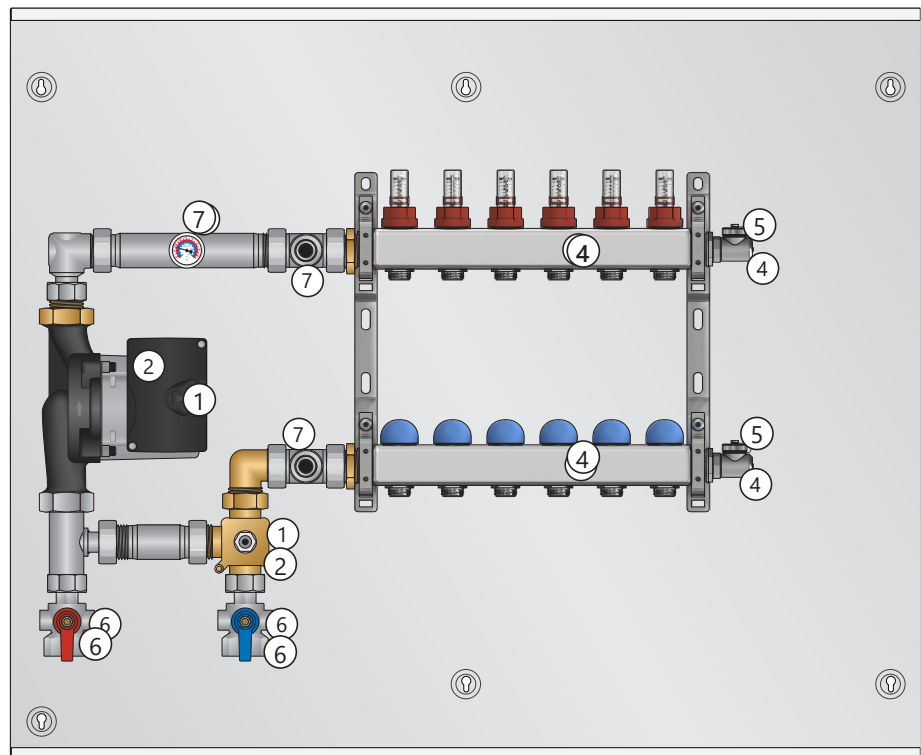
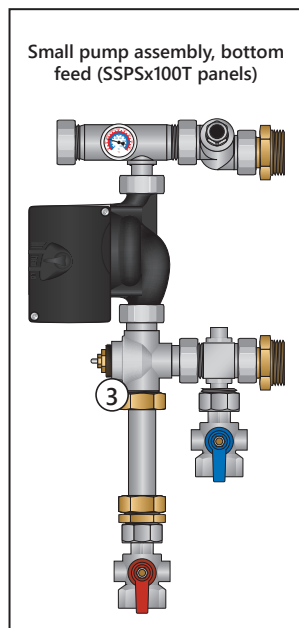
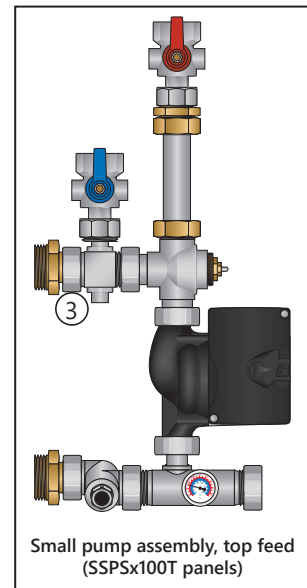

Panel Components Breakdown

#	Components	Component Description/Specifications	Part Number (Qty.)		
			SSPSx1xxx	SSPLx1xxx	SSPLx2xxx
1	Pump	The pump moves heated fluid through the hydronic system when there is a call for heat from the thermostat. Factory set to 3rd speed.	UPS15-58 (1)	UPS26-99 (1)	UPS26-99 (1)
2	Diverting valve	3-way diverting valve (SSPL series)	(1)	(1)	(1)
3	Mixing valve	3-way mixing valve (SSPS series)			
4	Manifold	Supply and return manifold with flow meters	76100 series	76100 series	76200 series
5	Hosebib	Allows for system fill and purge	(2)	(1)	(2)
6	Isolation valves	Isolates panel for servicing	(2)	(1)	(2)
7	Thermometer	Displays supply water temperature; range of 32°F - 210°F (0°C - 100°C)	(1)	(1)	(1)
8	Accessory pack		(1)	(1)	(1)
	i	Mounting screws	(4)	(1)	(4)
	ii	1" nitrile washers	(2)	(1)	(2)
Optional Installed Items					
9	SSAPB	Installed accessory - pressure bypass for SS manifolds		76945	
10	SSATH	Installed accessory - thermostatic head for manifold mixing panels	-	-	-
Sold Separately					
11	PEX to manifold connectors (F1807 Press system)	1/2"	77105		
		5/8"	77119		
		3/4"	77122		
12	PEX to manifold connectors (F1960 Expansion system)	1/2"	EX77305		
		5/8"	EX77319		
		3/4"	EX77322		

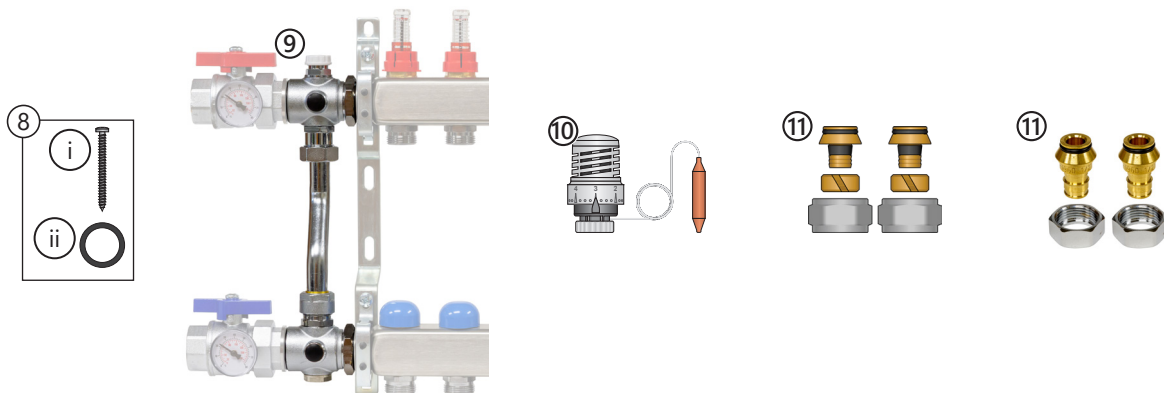

Pump Curves

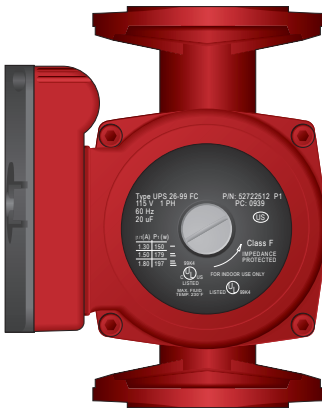
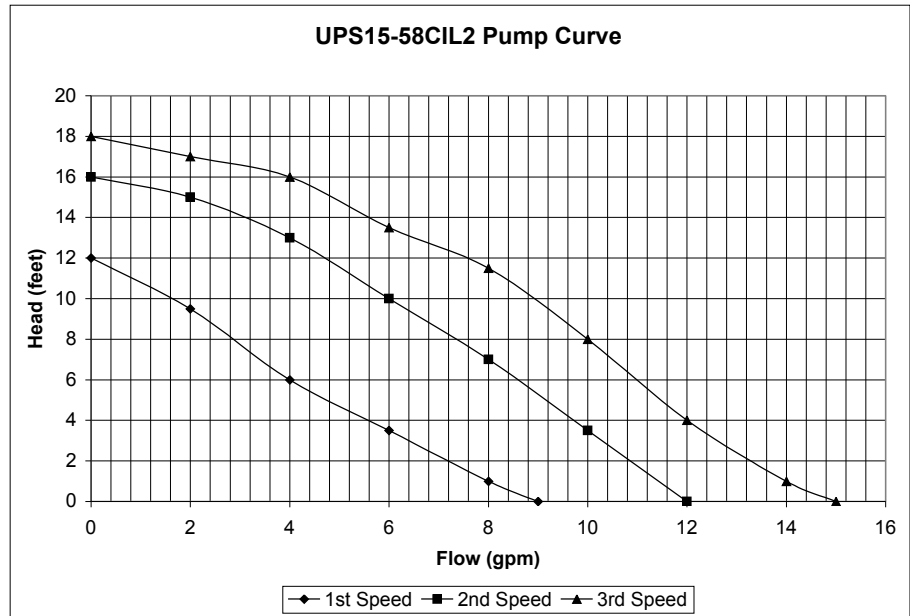
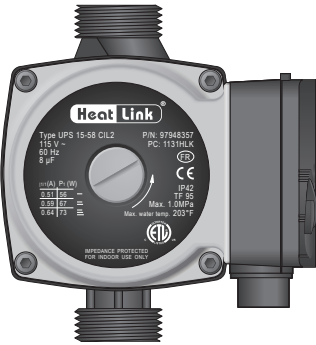

*Pump may not be exactly as illustrated

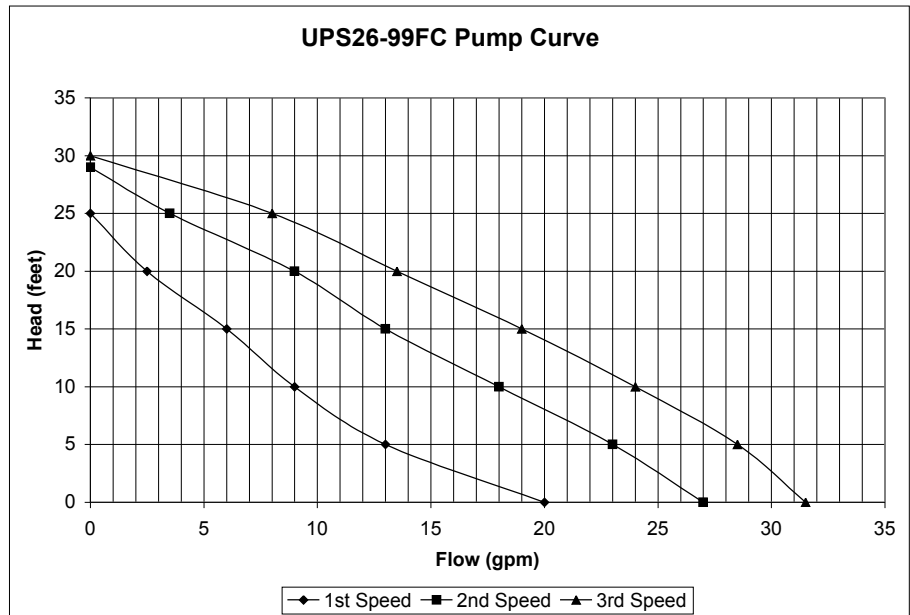

Optional Add-Ons

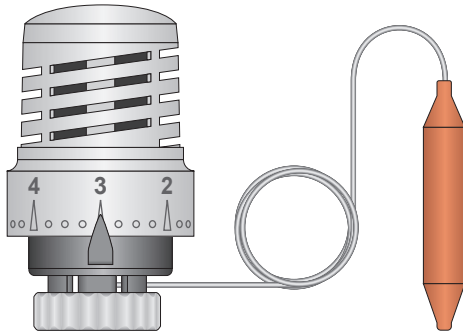

SSATH - Optional Installed Accessory Thermostatic Head

Used as thermostatic control for the mixing valve.

Specifications:

- Temperature Setting Range: 68-158°F (20-70°C)
- Sensor: Liquid filled contact sensor

Notes: Do not use any tools when installing the thermostatic head onto the zone valve! Hand tighten only!

Do not kink capillary when installing the head!! Doing so will render the capillary unusable.

Setting	Temperature	
	°F	°C
1	68	20
2	83	28
3	98	37
4	113	45
5	128	53
6	143	62
7	158	70

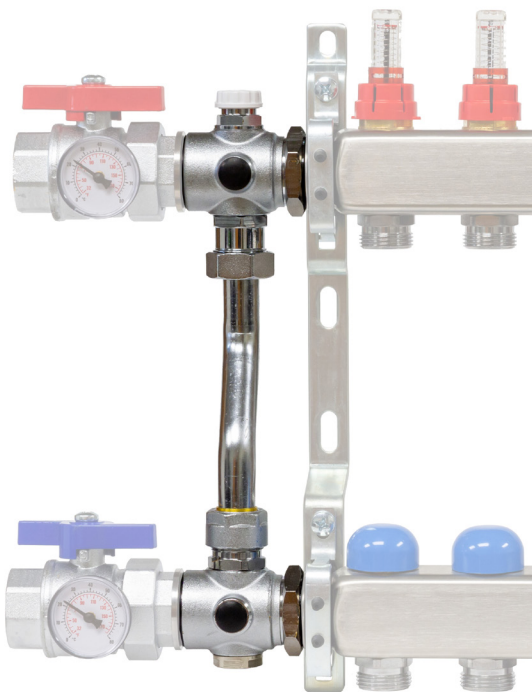

SSAPB - Optional Installed Accessory Pressure Bypass (#76945)

Adjustable pressure bypass valve kit for 76100 and 76200 series stainless steel manifolds. This valve prevents a steep rise of the pump head and maintains flow at a stable rate. Also ensures only required amount of circulating water is used for hydronic systems.

Specifications:

- Adjustment Range: 0.63-4.63 Cv (0.54-4.00 Kv)

Panel Mounting - Recessed Enclosure

Prior to mounting the panel, ensure the wall is capable of supporting the weight of the panel, and that all required power outlets and/or wiring is available at the installation location.

Step 1 Use a screwdriver or similar thin tool through the hole to bend the mounting tabs out 90 degrees from the enclosure.

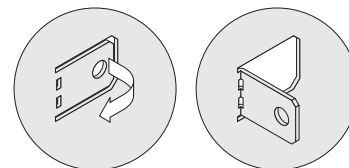

Step 2 If electrical wiring will be coming out the top of the panel remove the appropriate knockouts.

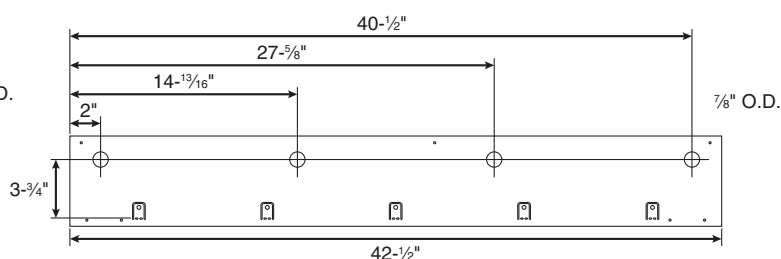
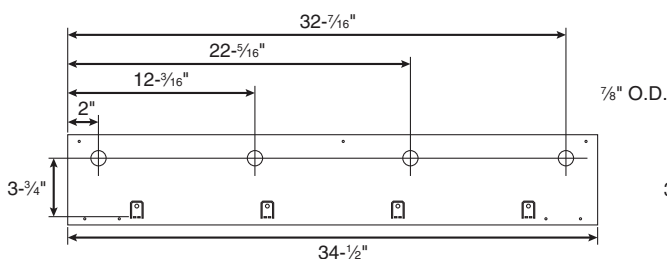

Step 3 Build a 2x6 supporting frame where the panel is to be mounted. The panel should be mounted at least 12" from the floor.

Step 4 Lift and place the panel onto the supporting frame.



Warning - panel is heavy; 2-3 person lift is required

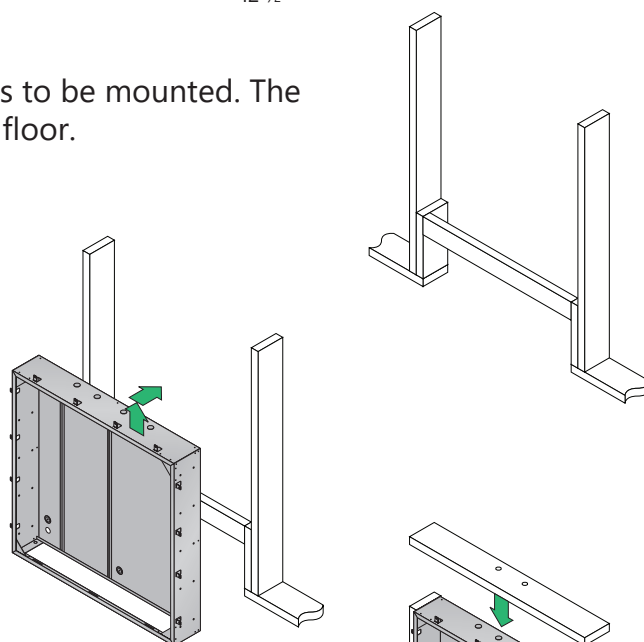

Step 5 Complete the supporting frame by adding a top plate. Be sure to drill corresponding holes in the top plate if any knockouts were removed.

Step 6 Secure the panel in place by putting screws into each of the mounting tabs.

Note: Panel contents are not shown in the mounting diagrams.

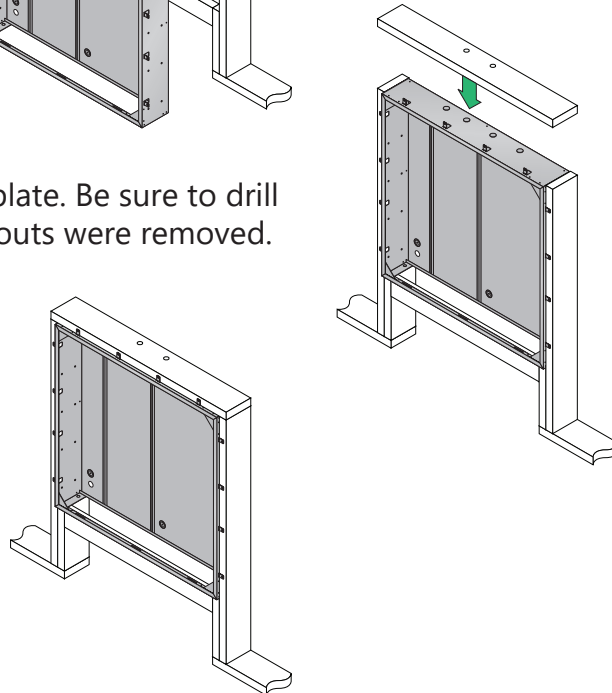

Panel Mounting - Surface Enclosure

Prior to mounting the panel, ensure the wall is capable of supporting the weight of the panel, and that the required 110V wiring is available at the installation location. See controls manual for wiring details. The top of the panel should be a minimum of 4 feet from the floor, with sufficient space left at the bottom for required piping.

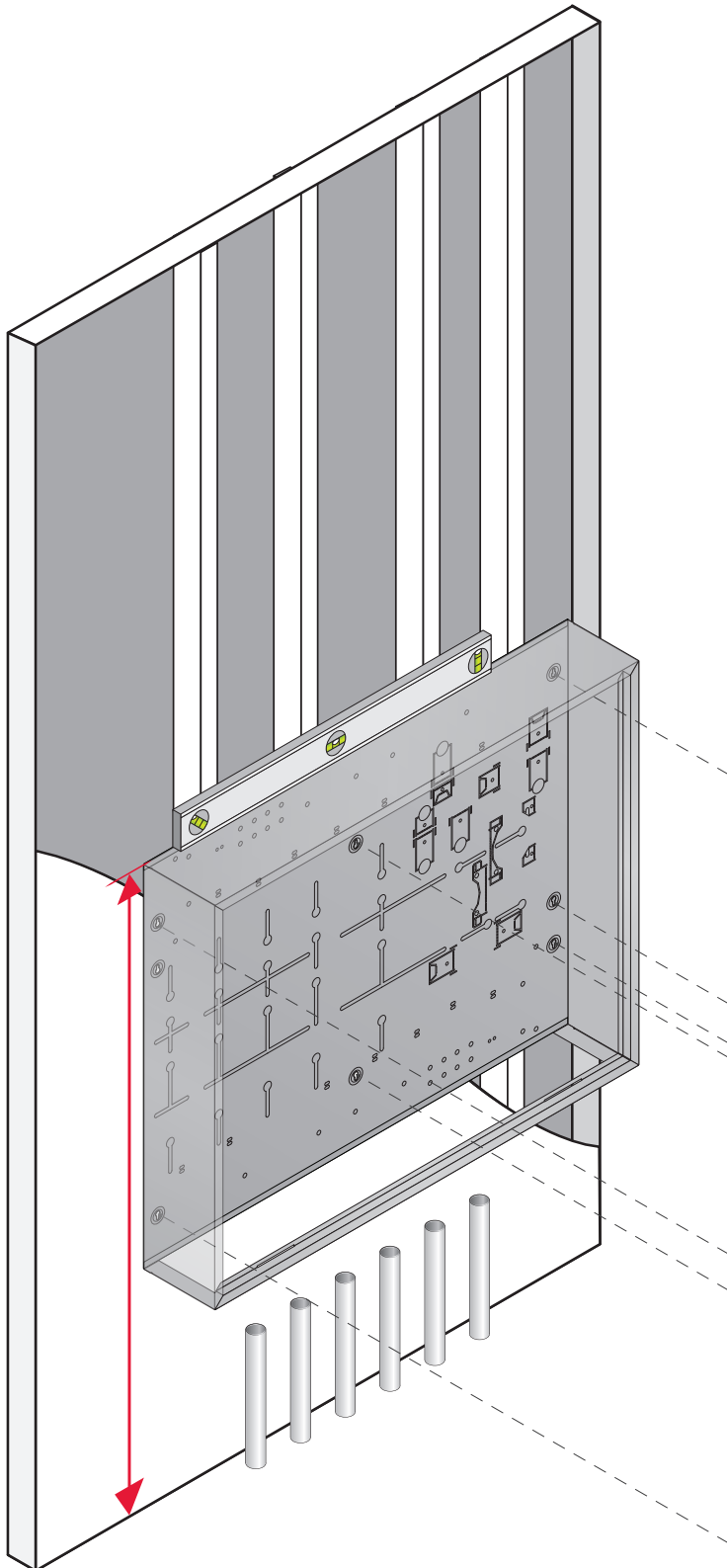

- Step 1** The panel mounting position needs to allow for enough room to access the system tubing. A minimum of 12" is recommended.
- Step 2** Mark stud locations. *If the panel cannot be secured directly to the studs, a backing board may be needed to properly install the panel.*
- Step 3** Screw three of the supplied mounting screws into the studs or backing board leaving 1/4" of the screw out of the wall.
- Step 4** Lift and place the panel onto the mounting screws using the keyhole slots.
- Step 5** Screw the remaining mounting screws into place, and tighten all screws.
- Step 6** Refer to piping hookup, fill and purge, and wiring instructions before replacing the cover.

Piping Hookup

- Step 1 Before making any connections, identify the required connections to and from the panel.
- Step 2 Connect mains piping using 1" MNPT fittings.
- Step 3 Connect all tubing to manifold connectors (77100 connectors sold separately).

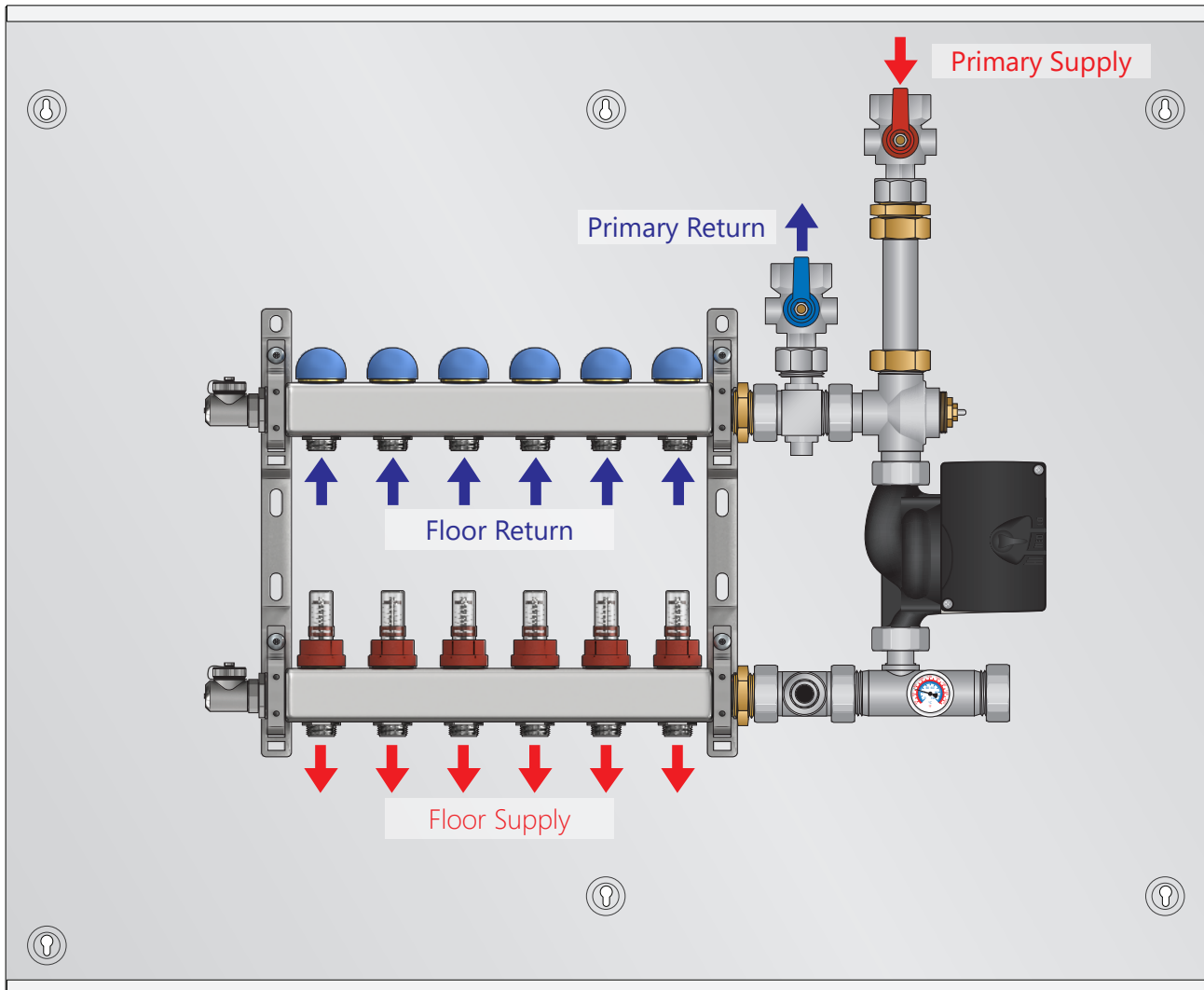

SSPSX106T shown

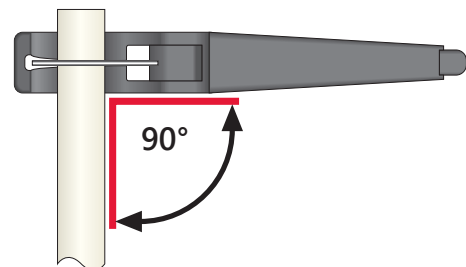

Ensure all PEX-a tubing is cut at a 90° angle for best results when connecting to the manifold.

PEX Tubing to Manifold Connections using #77100 Series Connectors (sold separately)

77105 1/2", and 77119 5/8" Connectors include a nut and split ring ferrule pre-assembly, and a brass insert with O-ring.

1. Inspect all components for debris, obstructions, and/or damage prior to installation.
2. Lubricate the inside of the manifold port with silicone o-ring lubricant (#79952).
3. Cut the PEX tubing at a 90° angle.
4. Place the Nut and Ferrule pre-assembly onto the PEX tubing.

Method A

5. Push the Brass Insert into the PEX tubing as far as it will go.
6. Push the PEX tubing with Brass Insert as far as it will go into the connector base. Ensure the o-ring is clean and take care not to pinch it.
7. Use a wrench to tighten the nut.

Method B

5. Push Brass Insert as far as it will go into the manifold. Ensure the o-ring is clean and take care not to pinch it.
6. Push PEX tubing onto the Brass Insert as far as it will go.
7. Use a wrench to tighten the nut.

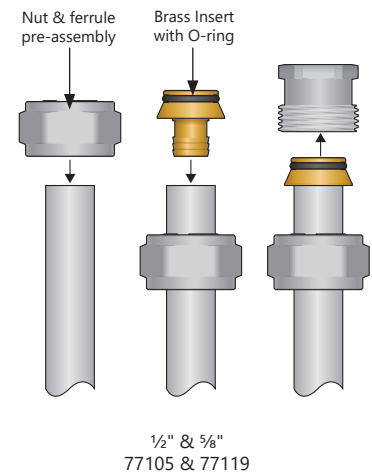

#77122 3/4" Connectors include a brass insert with O-ring, split ring ferrule, and nut.

1. Inspect all components for debris, obstructions, and/or damage prior to installation.
2. Lubricate the inside of the manifold port with silicone o-ring lubricant (#79952).
3. Cut the PEX tubing at a 90° angle.
4. Insert the split ring ferrule into the nut first. Open the split to ease insertion of the PEX.

Method A

5. Push the Brass Insert onto the PEX tubing as far as it will go.
6. Push the PEX tubing with Brass Insert as far as it will go into the connector base. Ensure the o-ring is clean and take care not to pinch it.

Method B

5. Push Brass Insert as far as it will go into the manifold. Ensure the o-ring is clean and take care not to pinch it.
6. Push PEX tubing onto the Brass Insert as far as it will go.
7. Use a wrench to tighten the nut.

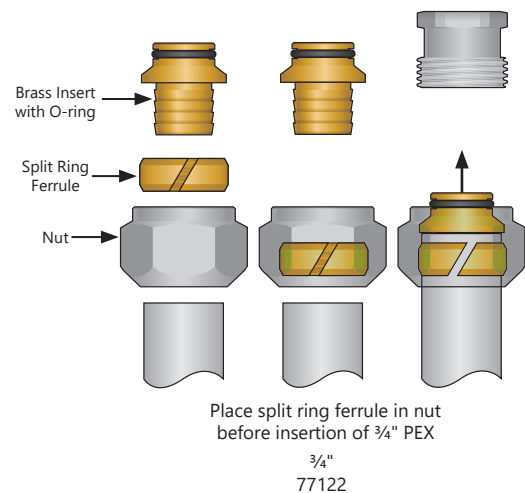

PEX Tubing to Manifold Conns using #EX77300 Series Expansion Connectors (sold separately)

#EX77300 Series Connectors (EX77305 1/2" and EX77319 5/8" and EX77322 3/4") include a nut and F1960 brass insert.

1. Inspect all components for debris, obstructions, and/or damage prior to installation.
2. Lubricate the inside of the manifold port with silicone o-ring lubricant (#79952).
3. Cut the PEX tubing at a 90° angle.
4. Push the brass insert to the manifold connector.
5. Use a wrench to tighten the nut.
6. Expand tubing and PEX ring, and place on brass insert.

For additional expansion fitting installation info see L3240 PEX-A Potable Expansion System Installation Guide

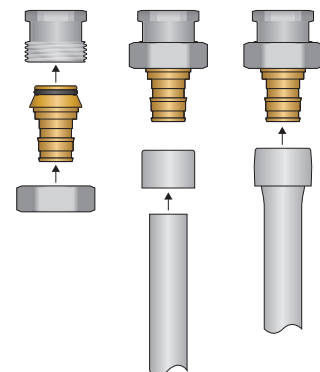

Fill & Purge

The following steps are recommended in order to fill the panel with water and purge entrained air once piping is completed, and before activation of the panel.

Use a pail to collect and dispose of the purged fluid.

Note: Additional fill & urge steps may be required for the rest of the hydronic system.

Isolation and drain valves are not included with the panel, but are necessary to properly fill and purge the panel, and to isolate the panel for service.

- Step 1 Ensure the panel is not plugged in.
- Step 2 **For small pump assemblies:** Adjust the mixing valve G so that it is fully open (ie. the cap is removed),
or
Remove the DDC actuator or Thermostatic head, if installed.
For large pump assemblies: Manually adjust the diverting valve so that it is fully open.
- Step 3 Fully close valves A, B, and C.
- Step 4 Fully close all supply E and return F manifold valves.*
- Step 5 Fully open valve D.
- Step 6 Attach purge hose (not included) to D.
- Step 7 Pressurize the main supply line. Open valve B.
- Step 8 Open the first return manifold valve E. Watch the hose in the pail/drain until you observe a steady stream of water (no air or spitting). Close the first return manifold valve.
- Step 9 Repeat step 9 for each loop until all loops are filled with water, and air is purged from pipes.
- Step 10 Purging is complete when there is not more air and/or spitting.
- Step 11 Close valve D then valve B.
- Step 12 Remove hose from drain valve D.
- Step 13 Check for leaks at connections. If any leaks are found carefully tighten (using a back-up wrench) until leak stops.
Do not overtighten.
- Step 14 Re-install the DDC actuator or thermostatic head, if applicable.

*If the return manifold has the optional 56201 actuator valves installed you must either remove them for the fill & purge process, or ensure that they are in the open position when filling the corresponding loop.

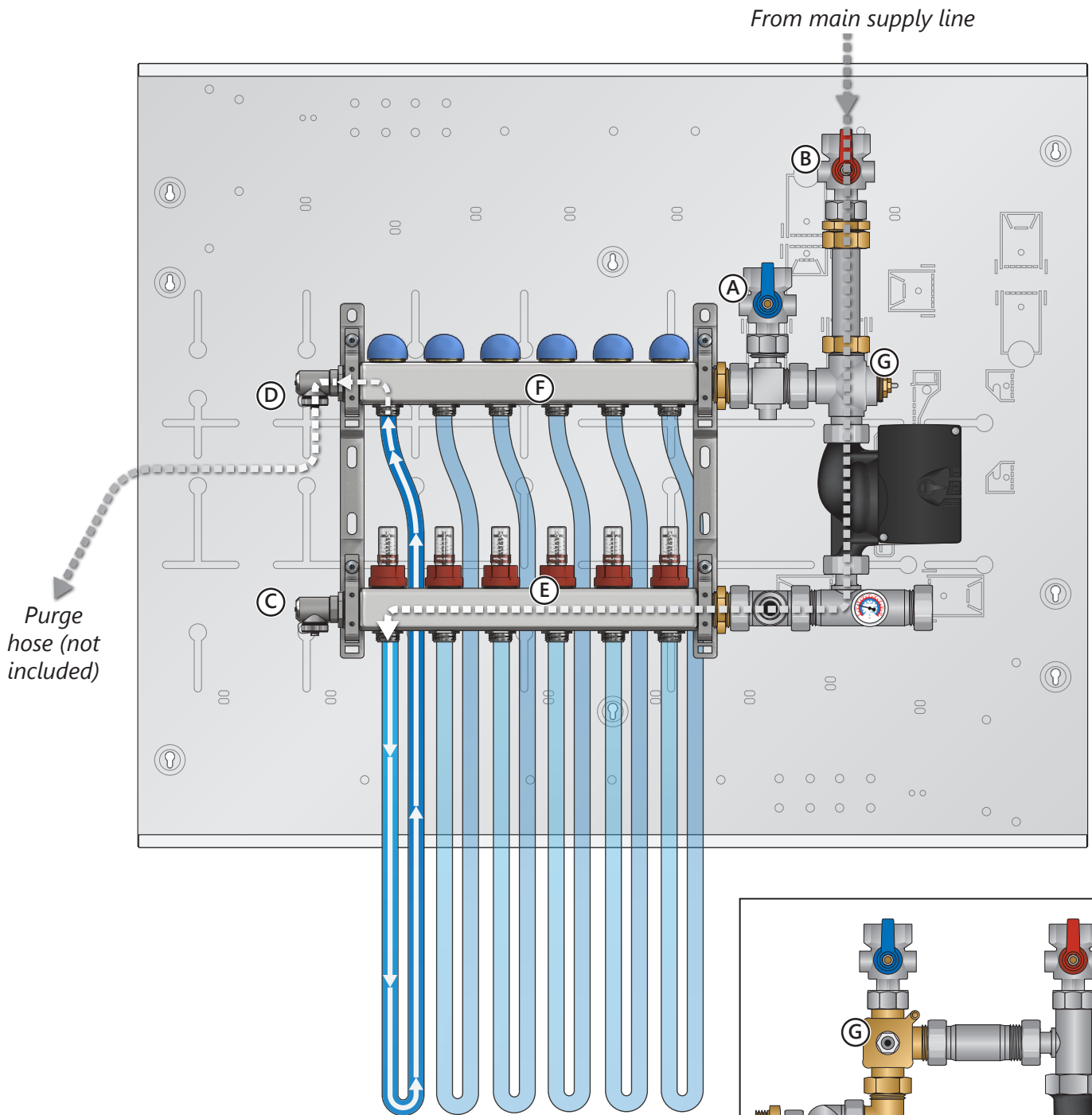

Notes

- Hose bib thread is 3/4" GH thread. **2**
- After fill procedure: the drip cap **1** should be placed back on to the hose bib **2**

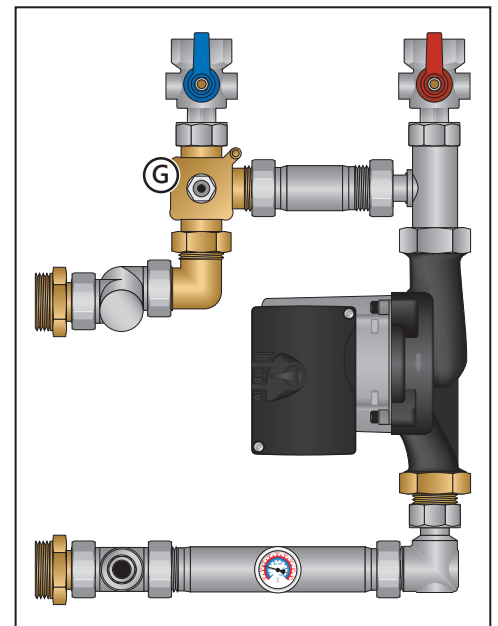
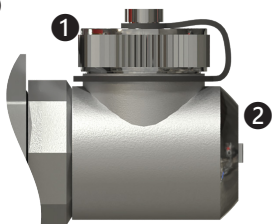

Large pump assembly, for reference

Balancing (75100 series with Flow Meters)

HeatLink Stainless Steel Manifolds (75000 series) are balanced on the supply side only.

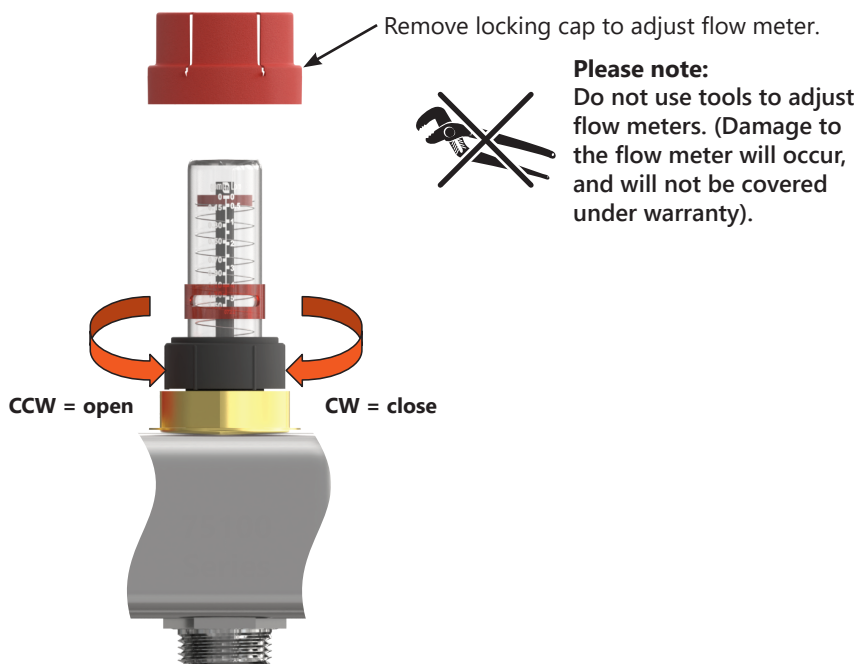

Flow meter balancing adjustment range: 0-2 US gpm or 0-7.5 L/min.

Balancing Method:

1. Ensure all supply valves are open [factory open].
2. Ensure all return valves are open (remove blue cap).
3. Adjust the flow meters to desired setting using the above chart.
4. Loops adjusted first may need to be re-adjusted once all other loops have been set.

Flow Meter Opening Turns	CV	KV
1	0.35	0.30
1.25	0.39	0.34
1.5	0.46	0.40
1.75	0.56	0.48
2	0.70	0.60
2.25	0.92	0.79
2.5	1.06	0.92
2.75	1.21	1.05
3 - Fully Open	1.39	1.20

Return Zone Valves Fully Open

Balancing Notes:

Supply : Use for primary balancing / fine tuning the flow rate. Remove locking cap to adjust the flow meter by hand, do not use tools.

Return: No balancing available. Cap is used for shut off only.

Balancing (75200 series High Flow)

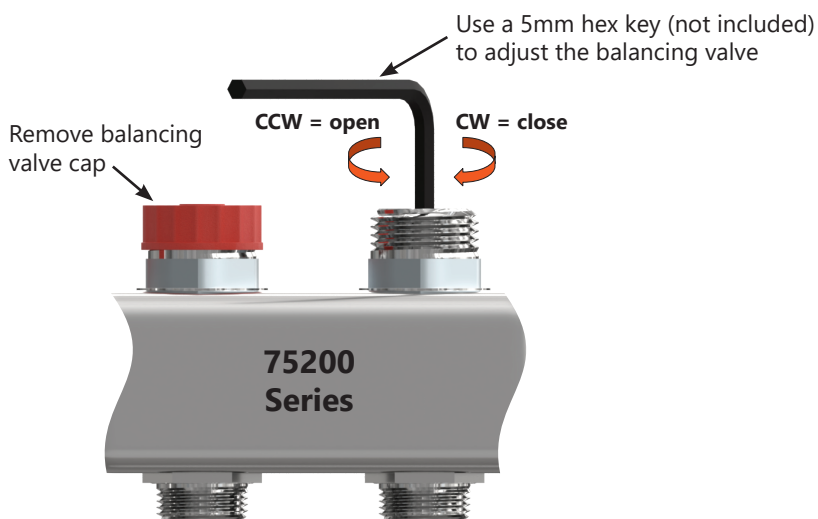

Balancing Valve Opening Turns	CV	KV
1	0.33	0.29
1.5	0.65	0.56
2	0.85	0.73
3	1.39	1.20
4	1.79	1.55
5	2.46	2.13
5.5 - Fully Open	2.73	2.36

Return Zone Valves Fully Open

Balancing Method:

1. Ensure all supply valves are open [factory open].
2. Ensure all return valves are open (remove blue cap).
3. Adjust the balancing valves to desired setting using the above chart.
4. Loops adjusted first may need to be re-adjusted once all other loops have been set.

Balancing Notes:

Supply : Use for primary balancing / fine tuning the flow rate. Remove balancing valve cap and use a 5mm hex key (not included) to adjust.

Return: No balancing available. Cap is used for shut off only.

75100 Series Friction Head Graph

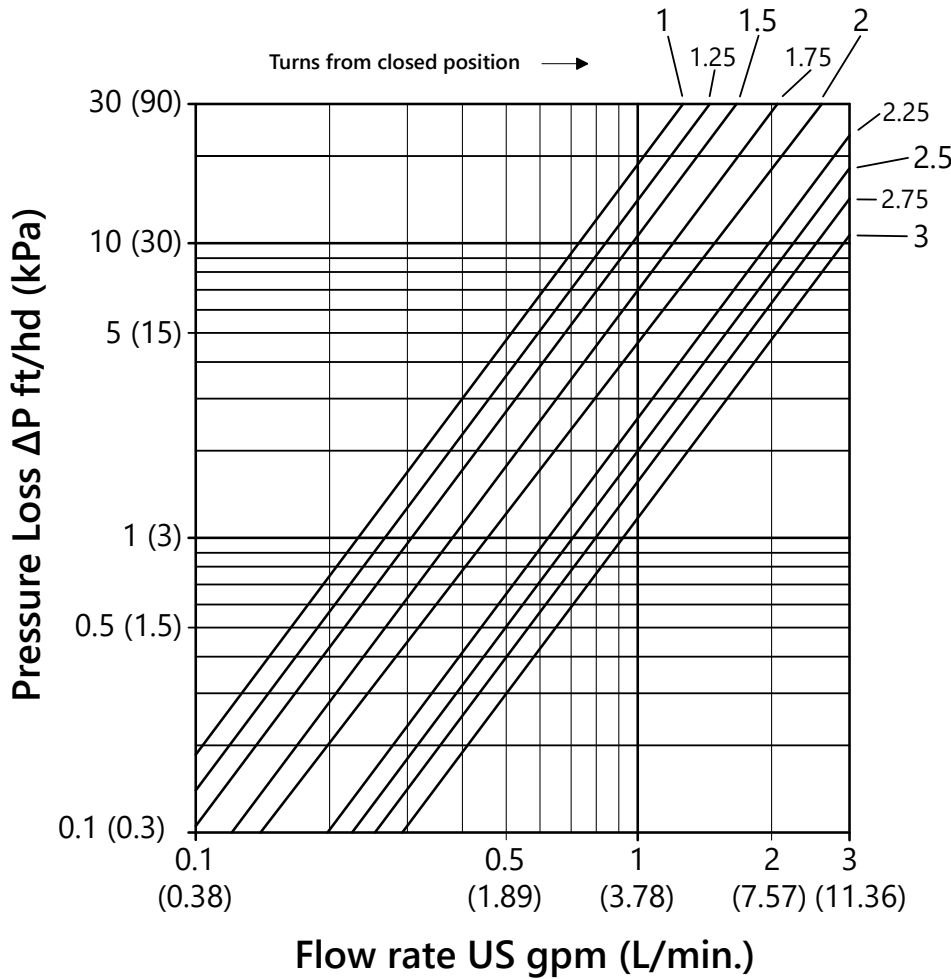

75100 Series Technical Data

Operating pressure87 psi (6 bar)
Maximum pressure at 70°F (21°C).....	145 psi (10 bar)
Maximum continuous working temperature	160 °F (71 °C)
Maximum intermittent working temperature.....	185 °F (85 °C)(maximum 10 minutes/day)
Maximum differential pressure.....	14.5 psi (1 bar)
Heat Transfer Fluid.....	Water / Mixture of water with anti-freeze liquids
Maximum glycol percentage.....	50%
Flow meter scale.....	0 to 2 GPM (precision ± 10%)
Thermometer scale.....	32 to 175 °F (0 to 80 °C)
Supply Balancing Flow Meter (wide open)	Cv 1.39 (1.20 Kv)
Return Zone Valve (wide open)	Cv 3.24 (2.80 Kv)
Manifold Union.....	G1" Female
Full Port ball valve connection.....	1" NPT Female x G1" Male
Loop connections	G¾" Eurocone (EK20)
Hose bib connections.....	¾"GHT
Actuator adapter connection	M30x1.5
Manifold body material.....	Stainless Steel ASTM/AISI304 EN10088 1.4306
Brass components material.....	ASTM B124 C37700 (CW614N and CW617N)
Bracket material.....	Carbon steel white zinc plated

75200 Series Friction Head Graph

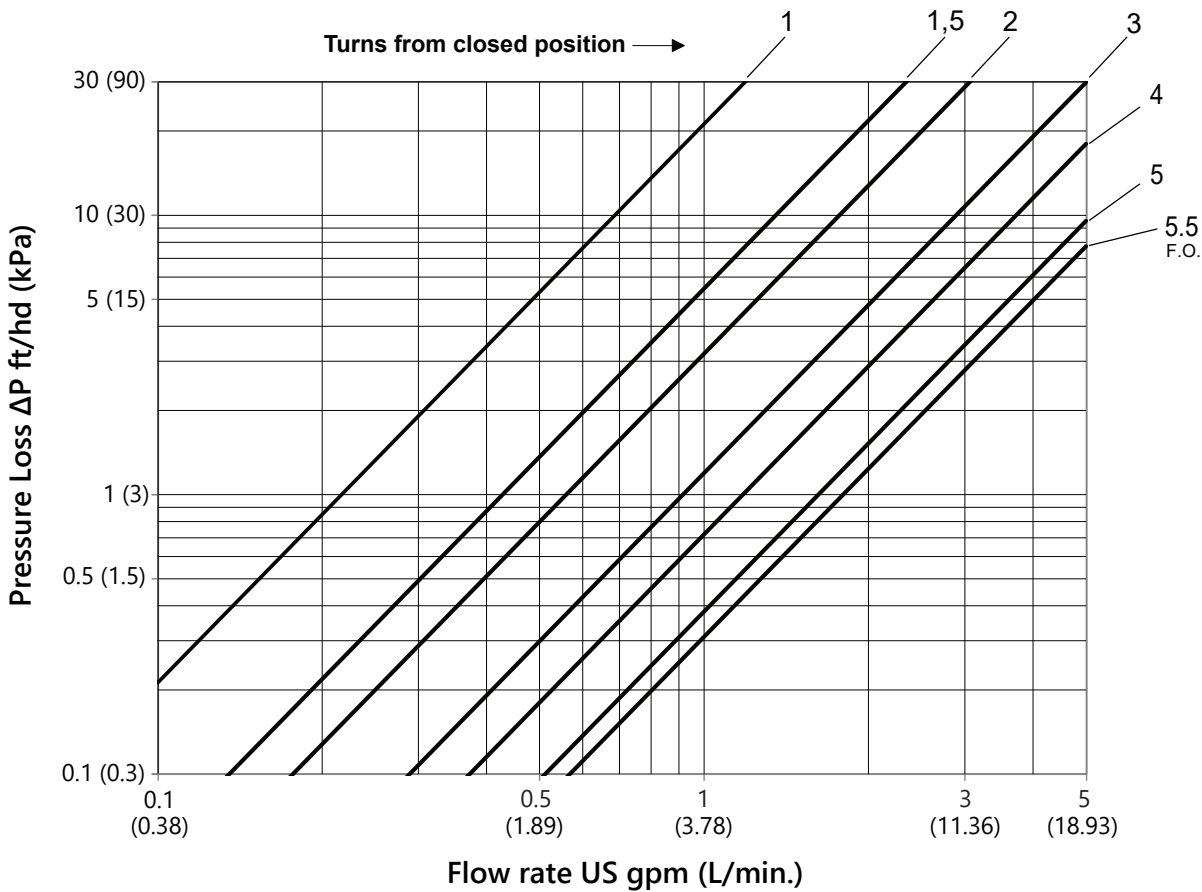

75200 Series Technical Data

Operating pressure	145 psi (10 bar)
Maximum continuous working temperature	185 °F (85°C)
Maximum Test Pressure	232 psi (16 bar)
Maximum differential pressure.....	14.5 psi (1 bar)
Heat Transfer Fluid.....	Water / Mixture of water with anti-freeze liquids
Maximum glycol percentage.....	50%
Thermometer scale.....	32 to 175 °F (0 to 80 °C)
Supply Balancing Valve (wide open).....	Cv 5.1 (Kv 4.41)
Return Zone Valve (wide open)	Cv 3.24 (Kv 2.80)
Global Flow Coefficient of the manifold	Cv 2.73 (Kv 2.36)(Supply + Return together)
Manifold Union.....	G1" Female
Full Port ball valve connection	1" NPT Female x G1" Male
Loop connections	G ³ / ₄ " Eurocone (EK20)
Fill and Drain valve connections	³ / ₄ "GHT
Actuator adapter connection	M30x1.5
Manifold body material.....	Stainless Steel ASTM EN10088 1.4306 (AISI304)
Brass components material.....	ASTM B124 C37700 (CW614N and CW617N)
Bracket material.....	Carbon steel white zinc plated

Troubleshooting

Problem	Check / Verify	Possible Cause
Low Temperature Within Room	Misplacement of thermostat location within room.	Make sure thermostat is not being influenced by an additional heat source, such as lighting or air duct.
	Low temperature setting of the thermostat.	Adjust the temperature setting on thermostat.
	The system fails to turn on if the thermostat is set to high setting	Thermostat may be out of calibration or defective. Replace thermostat.
	The electronic actuator fails to open during a call for heat	The electronic actuator may be improperly seated or may be defective. Replace if necessary.
	Low supply mixed fluid temperature.	Adjust the Mixing Valve to the appropriate settings.
	Wiring from heat source to panel.	Check that the wiring is done properly. Consult qualified electrician prior to alteration of wiring between heat source and panel.
	Output of heat source is unable to meet demand of heating system.	Compare output of heat source to the requirements of the heating system.
	Circulator is not on during a call for heat. (Use a stethoscope or similar device to verify)	The StatLink® module or circulator may be defective.
	A qualified electrician should verify 24V power is supplied to the thermostats and actuator.	The 24V transformer may have failed.
High Temperature Within Room	Check current setting of the thermostat.	Adjust the temperature setting on thermostat to a lower setting.
	High supply mixed fluid temperature.	Adjust the Mixing Valve to the appropriate settings.
	Installed electronic actuators remain open after the thermostat is satisfied.	An obstruction inside the zone valve is not allowing the actuator to fully close or the thermostat is still calling for heat.

Maintenance

Yearly maintenance should be done on the panel prior to each heating season to ensure the efficient and accurate operation of the panel.

Complete the following check list:

- Raise all thermostats to cause a call for heat within the system. Verify that the circulator starts, via a stethoscope or similar device.
- Confirm that the Auxiliary Contacts close.
- If applicable, verify that each zone valve opens during the call for heat – the actuator should be warm to the touch, the LED will light up (on 5620x models) and the white indicator should rise from the top of the actuator.
- Return all thermostats to a desirable setting.

You are now ready for another heating season with HeatLink.

Differential piping schematic

The recommended pressure differential for SSP panels is 20psi.
 In systems where there is a pressure differential higher than 20psi, SSPS panels (with the UPS15-58 pump) should be piped as per the schematic below to avoid valve noise or damage.

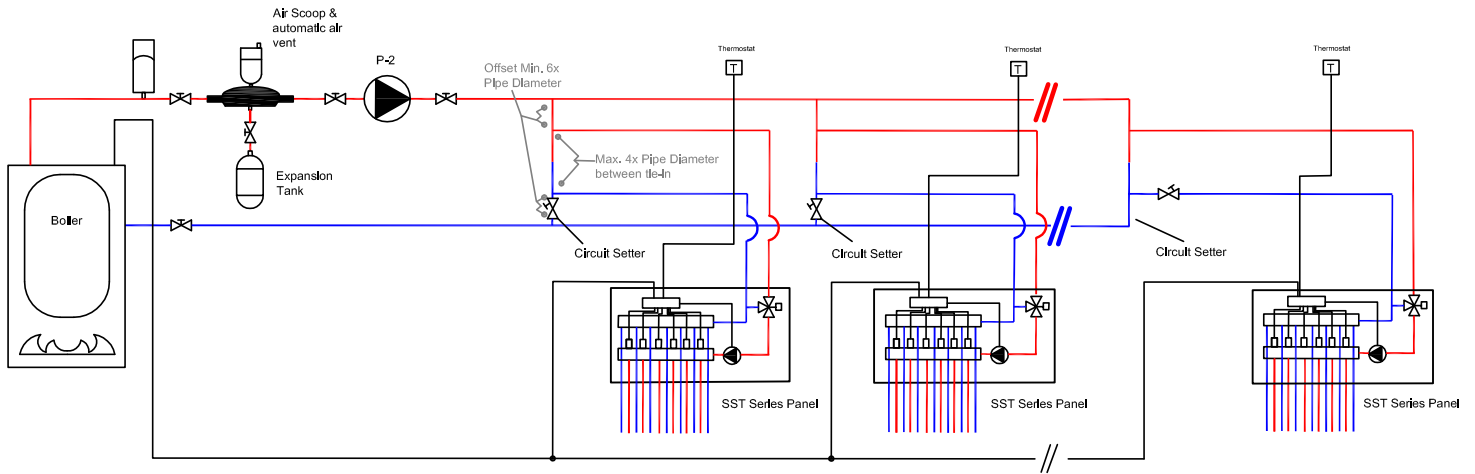



www.heatlink.com

Printed in Canada

January 24, 2024

©HeatLink Group Inc.