



HEP025RT

Installation, Operation, and Maintenance Manual

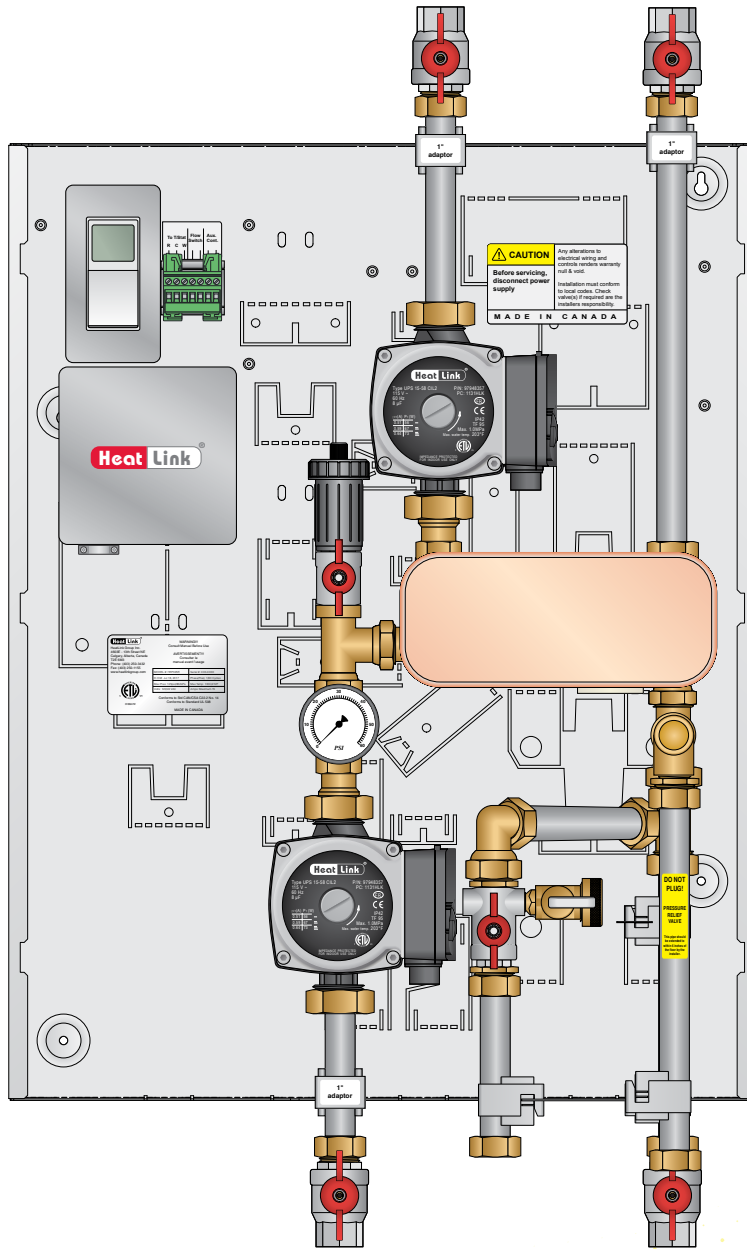

Table of Contents

4	Warnings
4	Servicing
5	Function
5	Unpacking
6	Panel Components
7	Panel Components
8	Specifications & Listings
9	Panel Mounting
10	Piping Hookup
11	Fill & Purge
12	Panel Wiring
12	Thermostat Wiring
12	Wiring Diagram
13	24hr Timer
13	Panel Control Sequence
14	Flow Switch Installation
15	Troubleshooting

Disclaimer

HeatLink Group Inc. shall not be responsible for errors in its brochures or printed materials. HeatLink Group Inc. reserves the right to alter its products at any time without notice, provided that alterations to products already on order shall not require material changes in specifications previously agreed upon HeatLink Group Inc. and the Purchaser. All trademarks in this material are property of the respective companies. HeatLink and the HeatLink logotype are trademarks of HeatLink Group Inc. All rights reserved.

Warnings

The zone control panel is for indoor use only and must be installed by a qualified installer/service technician. This product must be installed and operated in strict accordance with the terms set out in this manual and in accordance with the relevant requirements of the Local Authority Having Jurisdiction. Failure to comply will result in a void of warranty, and may also result in property damage, serious injury, or death.

Servicing

Prior to commencing installation of this panel it is necessary to read and understand all sections of this manual. The symbols below are used throughout this document to ensure proper operation of the panel, and your safety. Please pay attention to these symbols.



Warning
Possible Hazard



Warning
Live Power



Warning
Hot Pipes



Warning
Treated Water

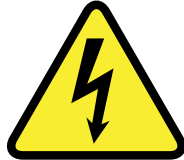

In order to avoid injury or death, switch off the power to the panel prior to inspecting or making connections to the terminal strip.

Function

This zone control panel can provide mixing, distribution, and zoning for a wide variety of hydronic heating applications.

The effectiveness of the system is dependant on the system being designed and installed correctly. Proper consideration of factors such as BTU loads, outdoor design temperature, indoor design temperature, room set-point temperature(s), differential fluid temperatures, head loss, flow rates, and transfer capacities of the heat emitters is critical.

Once these factors have been considered and the system requirements determined, these can then be evaluated and compared to the panel capabilities.

Note: This panel does not regulate or monitor the operating safety limit temperatures of the fluid leaving the heat source. Dependant on local codes, the HEP025RT panel may be suitable for application in either open or closed systems supplied with potable water, where the system utilizes the domestic hot water as a heat source for the hydronic system. In such cases, all components of the panel (and system components) must be specified as non-ferrous material, suitably approved for potable use. Prior to installation consult your Local Authority Having Jurisdiction to determine the suitability of such an application.

Unpacking

- Step 1** Examine carton for any damage that may have occurred during shipping. If damage is visible notify your courier and supplier immediately.
- Step 2** Open the carton by removing the staples.
- Step 3** Remove the cardboard spacers from the carton, then remove the panel from the carton. Lift the panel by the base, not the pipework.

Note: The HEP025RT does not include a cover.

Panel Components

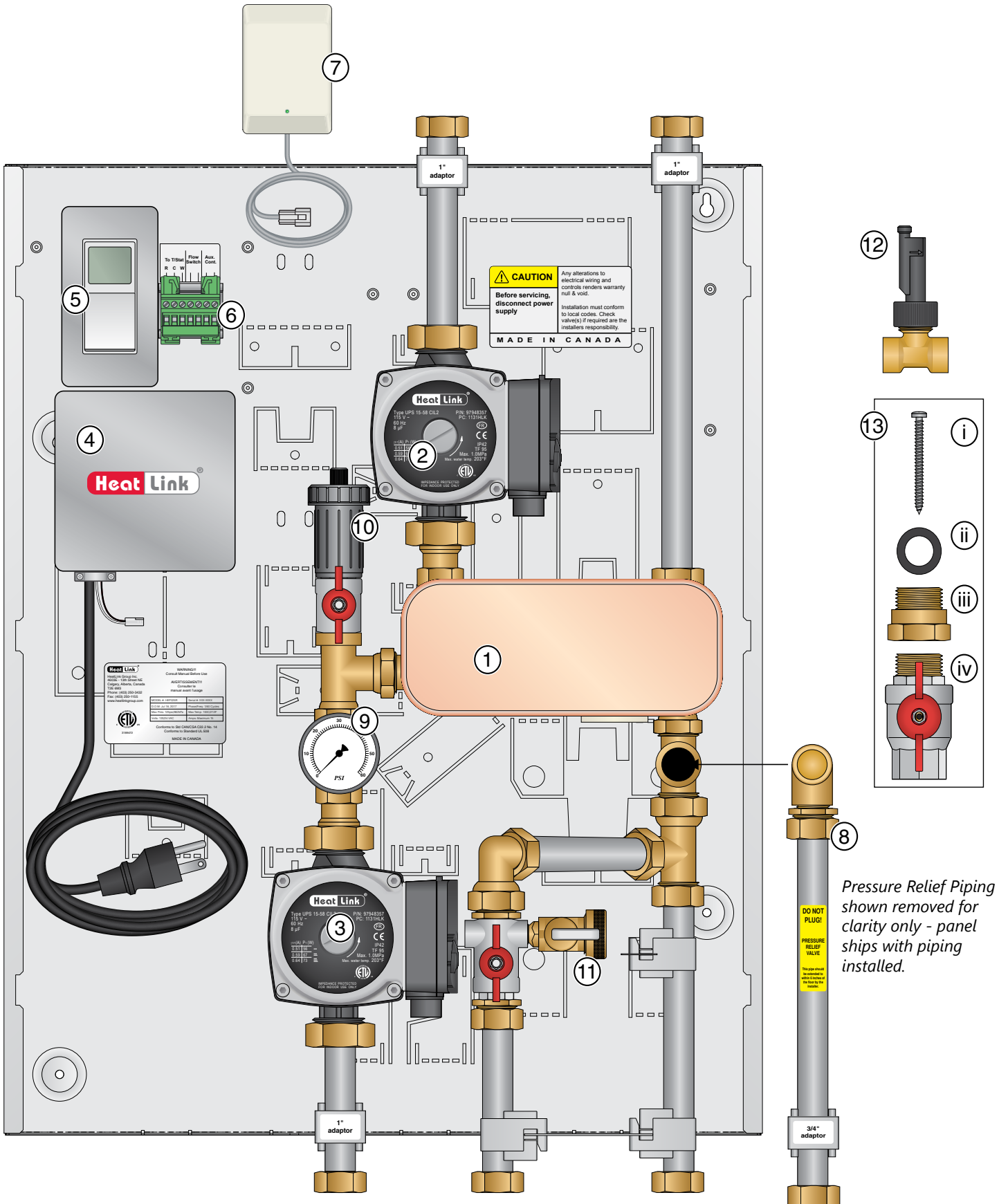

Pressure Relief Piping shown removed for clarity only - panel ships with piping installed.

Panel Components

#	Components	Component Description	Part Number (Qty.) HEP025RT
1	Single wall, brazed-plate heat exchanger	The heat exchanger provides separation of the primary and secondary loops.	n/a
2	Primary pump	The pump moves the heated fluid through the hydronic system when there is a call for heat from the thermostat. Factory set to 3rd speed. See pump curves below.	PUMP1558
3	Secondary pump		PUMP1558
4	Electrical box	Houses relays and wiring.	n/a
5	Timer	Circulates fluid for 15 minutes every 24 hours.	n/a
6	Terminal block	Provides easy access wiring for thermostats, flow switch (opt.), and aux. contacts.	n/a
7	24Vac 40VA plug-in transformer	Provides power to the panel electronics.	PLINTR40VA
8	½" Safety relief valve	For pressure relief only. Furnished without a lever. 1/2"female drain. Pressure range 75-175psi (5.17-12.06 bar). Setting 50, 75, 125 and 150psi (3.45, 5.17, 8.61 and 10.34 bar). This protects the system from thermal expansion pressure buildup during times when reducing valve thermal expansion bypass is ineffective due to high inlet water pressure.	n/a
9	Pressure gauge	The rear connection pressure gauge reads the secondary loop pressure. May not be exactly as shown. Range: 0-60psi	n/a
10	Automatic air vent	Automatic air vent purges air trapped in the secondary loop. May not be exactly as shown.	79932
11	Drain and fill valve	Access point for filling and draining the panel.	n/a
12	Optional flow switch	The electronic flow indicator provides DHW priority when the DHW flow rate reaches a factor pre-set level (approx. 0.5 US gpm). Must be piped in downstream of panel.	FLWSWTCH
13	Accessory pack	Panel installation accessories.*	n/a
	i Mounting screw	Panel mounting screws.	(x4)
	ii ¾" Nitrile washer	Washers for installation of adapters, plus (4) spares.	NTRWSH34 (x10)
	iii ¾" MBSP x ¾" FNPT adapters	Adapters for expansion tank, and pressure relief piping.	(x2)
	iv ¾" isolation valve	Zone valve used to isolate the panel from the system during fill & purge, and maintenance.	(x4)
14	Optional cover	Powder coated cover	PC2319CVR

*Contact your HeatLink representative if the accessory pack is missing in whole or in part.

Specifications & Listings

	HEP025R
Listing	cETLus
Conforms to	CAN/CSA-C22 No.14, UL508
Dimensions	24"H × 18¾"W × 7¾"D
Weight	30 lbs
Nominal panel output *see conditions below	25,000 Btu/hr
Max ambient temperature	120°F
Max water temperature	200°F
Settable fluid temp range	dependant on heat source temperature
½" Safety relief valve	Calibrated adjustment allows for setting valve to required pressure relief. Adjustable range 50-175psi (3.45-12.06 bar). The Series 530C and LF530C is ideal for bypass thermal expansion pressure relief.
Power supply: pre-wired on system controller	120 V ac; max. current 2A
Primary pump	Non-ferrous, Grundfos UPS15-58CIL2
Secondary pump	Non-ferrous, Grundfos UPS15-58CIL2
Heat exchanger	Single-wall brazed plate; 3×8-12
Auxiliary terminal	Yes, dry contacts, max. load 10A
DHW priority	Optional @ ~0.5 US gpm DHW flow
Temperature control method	None
Piping	¾" 304 Stainless steel tubing
Piping connections	1" FNPT, ¾" FNPT
DHW priority switch connection	½" FNPT (FLWSWTCH optional)
Backplate	Galvanized steel
Enclosure	Powder coated steel

Panel Mounting

Prior to mounting the panel, ensure the wall is capable of supporting the weight of the panel. Ensure that a 120V receptacle is within reach of the 6-foot cord and plug and 24V plug-in transformer.

The top of the panel should be a minimum of 4 feet from the floor.

Step 1 Find and mark the wall stud locations. If the panel cannot be secured directly to the studs, or suitable backing boards, plywood may need to be installed behind the panel to properly secure it in place.

Step 2 Using a level, draw a line between the studs at a minimum of 4' from the floor.

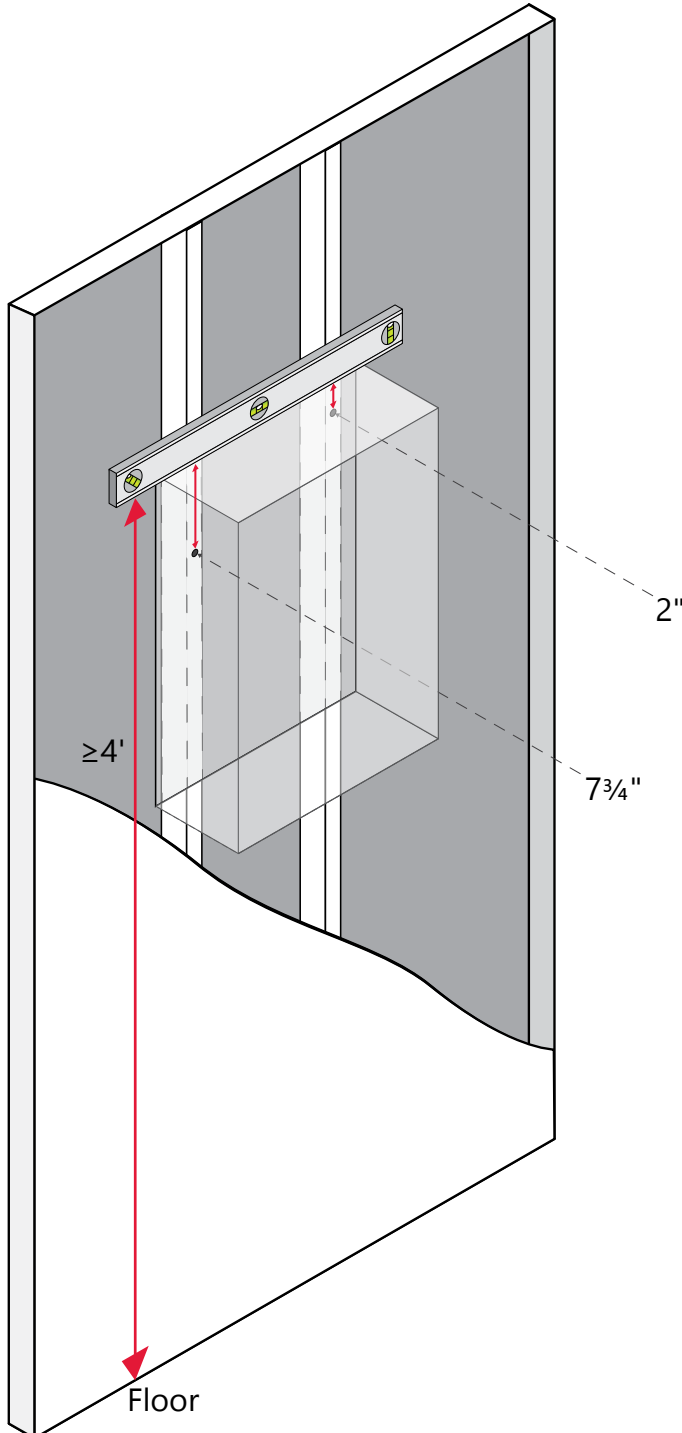

Step 3 Screw two of the supplied mounting screws into the wall studs (or backing plywood) at 2" and 7³/₄" below the desired height, leaving 1/4" of the screw out of the wall.

Step 4 Lift panel onto mounting screws.

Step 5 Screw remaining mounting screws into the holes at the bottom of the panel. Tighten the top two screws.

Step 6 Refer to piping hookup and fill and purge.

Step 7 See page 14 for optional flow switch installation instructions.

Piping Hookup

Before making any connections, identify the required connections to and from the panel (see page 5 for adapter sizes). The supplied rubber washers must be used.

- Step 1** Connect the valves (C) to copper pipe or PEX tubing using a MNPT fitting or adapter (D) (not included), and then to the panel pipework.
- Step 2** Connect MNPT adapter (not included) to copper pipe, or tubing E.
- Step 3** Screw supplied M×FNPT adapter C onto D using appropriate thread sealant.
- Step 4** Place included rubber washer B on flat surface of C, and place against flanged edge of stainless steel pipe.
- Step 5** Slide nut A over adapter C and finger tighten, then using two 30mm wrenches tighten the nut - **do not overtighten the nut as this will damage the rubber washer.**
- Step 6** See page 14 for optional flow switch connection instructions.

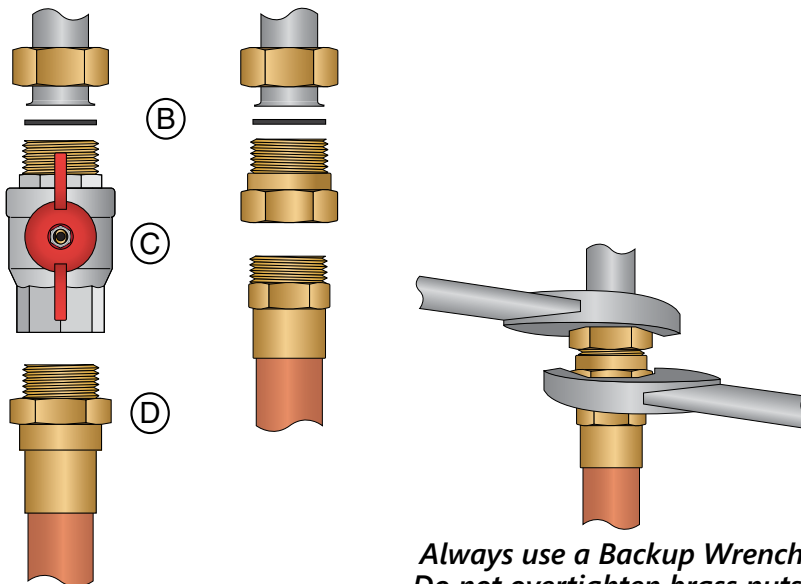

**Always use a Backup Wrench
Do not overtighten brass nuts!**

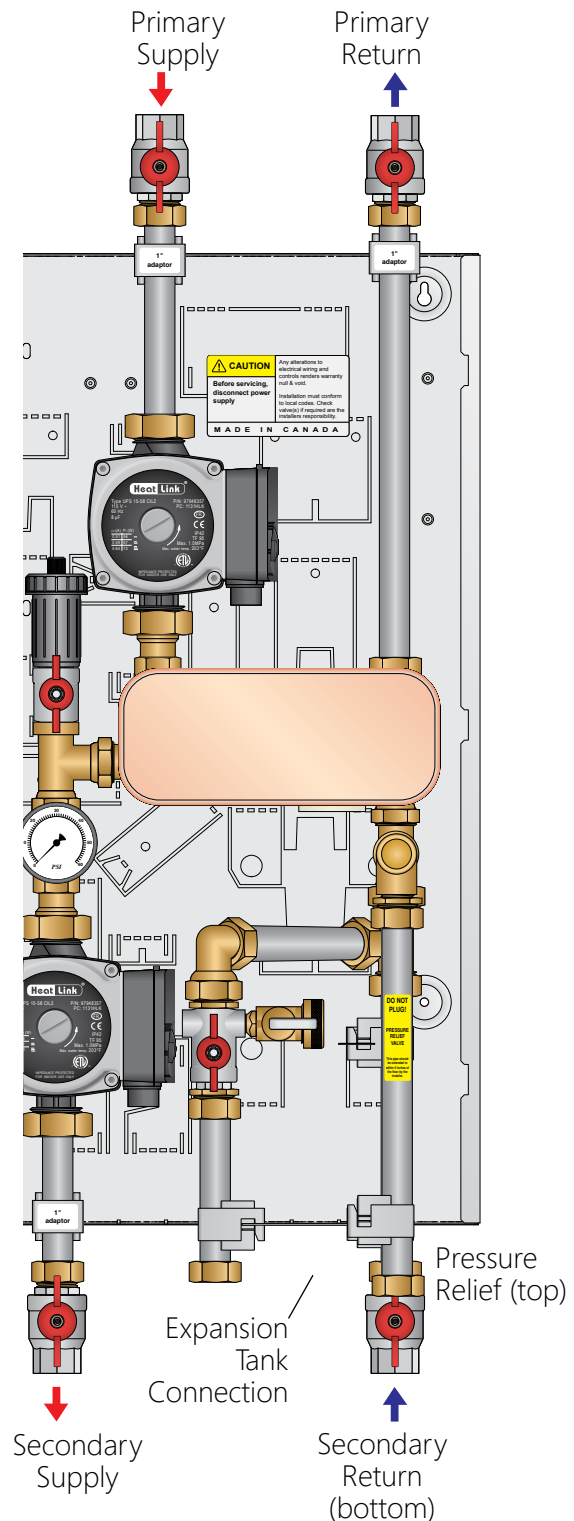

Fill & Purge

The following steps are recommended in order to fill the panel with water and purge entrained air once piping is completed, and before activation of the panel.

Note: Additional steps may be required for the rest of the hydronic system.

Note: Because the panel contains a heat exchanger, each side of the panel must be filled and purged separately.

Note: Isolation and drain valves are not included with the panel, but are necessary to properly fill and purge the panel, and to isolate the panel for service.

- Step 1 Ensure the panel is not plugged in.
- Step 2 Close all isolation and drain valves.
- Step 3 Attach fill and purge hoses (not included) as per diagram.
- Step 4 For system-side fill and purge, open valves (A), (B), (C), and (D).
- Step 5 When purged water is free of bubbles close valves (C) and (D).
- Step 6 For heating-side fill and purge, open valves (E), (F), (G), and (H).
- Step 7 When purged water is free from bubbles close valves (G) and (H).
- Step 8 Remove fill and purge hoses.
- Step 9 Vent both pumps using a large flat head screwdriver before starting system.

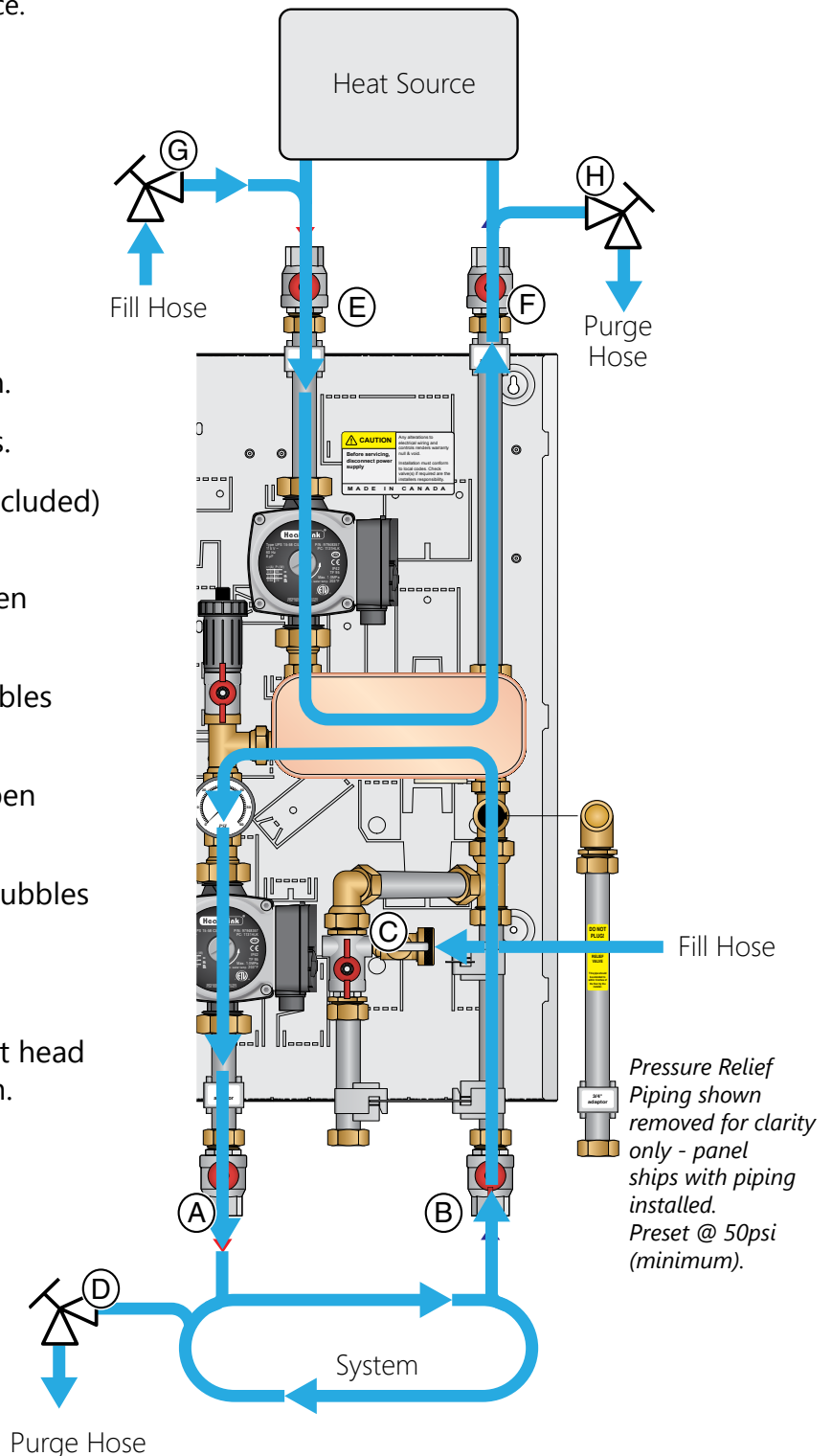

Panel Wiring

Thermostat Wiring



24V low voltage power may be supplied to the thermostat. Wiring of thermostat should be done by qualified electrician and should meet local codes and jurisdictions. Wiring to the terminal strip requires 18 gauge wire.



- Do not exceed 2VA per thermostat.
- Do not cross terminals C and R

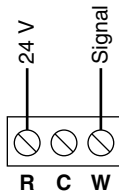

2-Wire Thermostat
(battery only or non-electric)

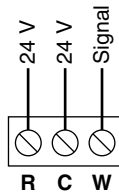

3-Wire Thermostat
(HeatLink thermostats)

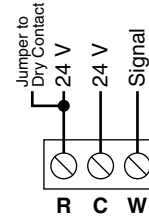

4-Wire Thermostat
(with dry contact signal)

Wiring Diagram

Other Contacts

Aux(iliary) Contacts: The auxiliary contact set is dry, meaning no supply of power is present at the terminal. The maximum allowable load is 10A. The auxiliary dry contact is for switching another device (ie. the heat source) when there is a call for heat.

Flow Sw(itch) Contacts: The wiring harness of the optional Flow Switch for DHW Priority (FLWSWITCH) uses these contacts (see page 14).

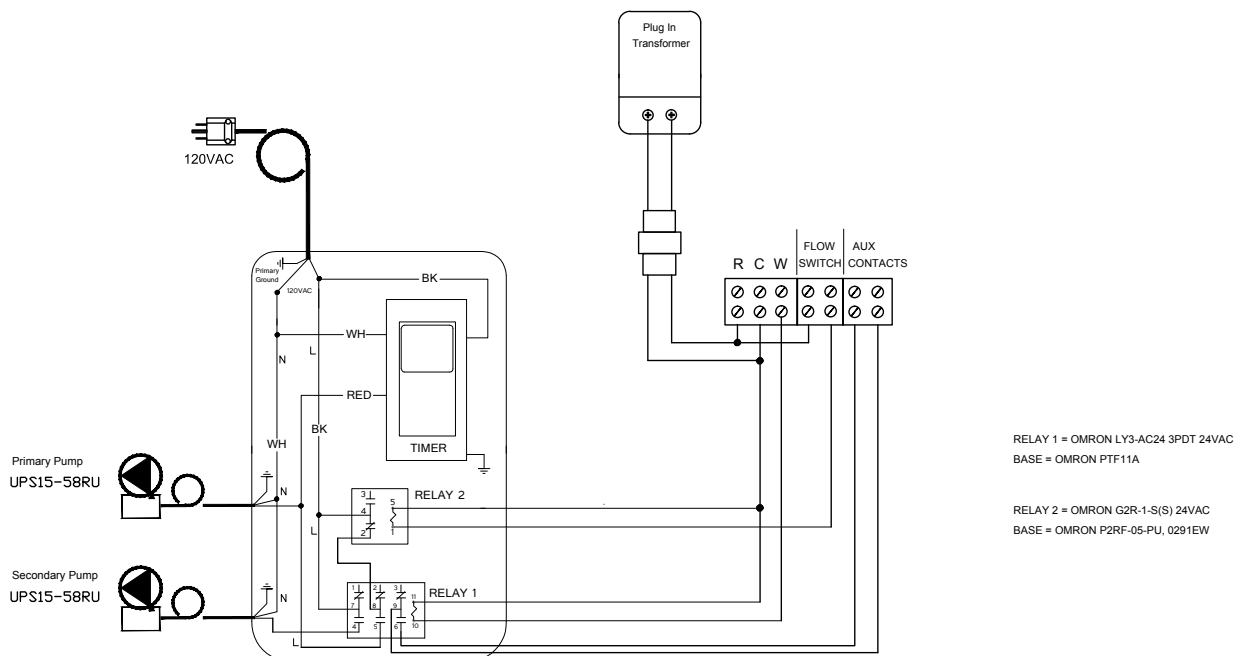

RELAY 1 = OMRON LY3-AC24 3PDT 24VAC
BASE = OMRON PTF11A

RELAY 2 = OMRON G2R-1-S(S) 24VAC
BASE = OMRON P2RF-05-PU, 0291EW

24hr Timer The HEP025RT features a timer which will activate the pump in order to circulate water within the system for 15 minutes every 24 hours. This prevents stale water from accumulating in an open system during periods of low heat demand (ie. summer).



It is recommended that any HEP025RT installed in an open system remain plugged in (with the thermostat on low during summer periods) in order to allow the timer to activate this circulation.

If the HEP025RT is installed in a closed system it can be unplugged during these periods.

The timer is set at the manufacturing facility for this function, and should not be altered.

See insert for detailed Timer instructions.

Panel Control Sequence

1. When the power cord ① and transformer ② are plugged in, the panel will be able to operate properly.
2. The timer ③ activates the primary pump for 15 minutes every 24 hours to ensure that potable water in the piping is not stagnant.
3. When a thermostat calls for heat, its internal 24V contacts close, the relays close, and both pumps ④ turn on.
4. When the requirements of the thermostat are met, the internal contacts of the thermostat open, the auxiliary contacts open, and the pumps stop.

Note: If the FLWSWTC optional DHW priority flow switch ⑤ is installed and the DHW flow is above the factory setting for this device, the primary pump stops. When the DHW flow drops below the factory setting the panel resumes normal operation.

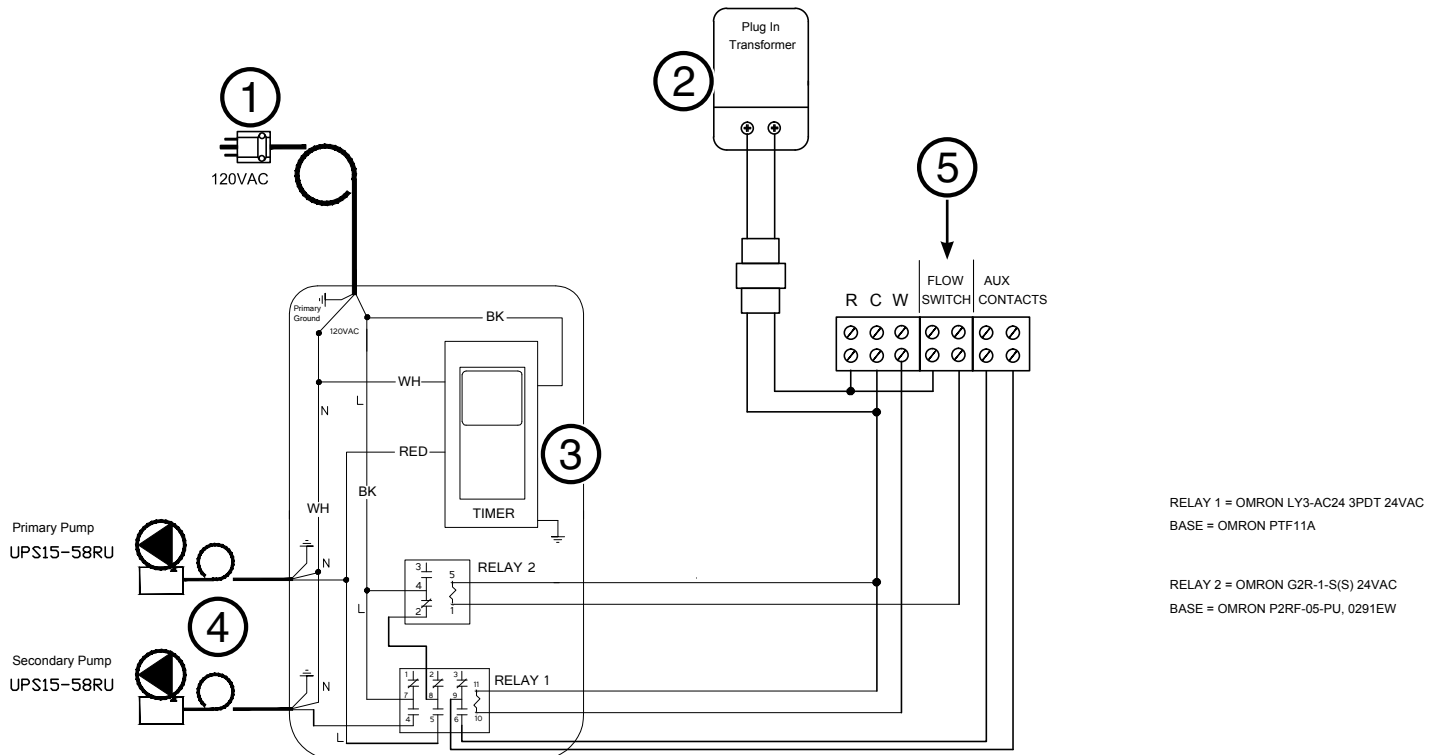

Flow Switch Installation

Sold separately, the optional flow switch for DHW priority can be easily installed by following the instructions below.

Notes:

- Make sure the cable to the flow switch isn't under tension.
- Clean the pipe system in which the flow switch is to be installed and remove any magnetic particles, e.g. welding residue.
- The straight in- and outlet pipe (in front of and behind the flow switch) has to be at least 2-1/2" (65 mm).
- The flow switch should be installed in an "upright standing position" in horizontal pipework.
- The switch should only be installed in a vertical position, deviation max. 45°.
- Make sure that there are no external magnetic fields or large ferromagnetic bodies in the immediate vicinity of the flow switch, since these can impair device functioning.
- Screw on the union plastic nut with a maximum torque of 8 Nm.
- To prevent overheating when soldering near the flow switch, the flow switch (body with paddle system) and the o-ring must be removed from the pipe section.

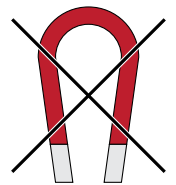
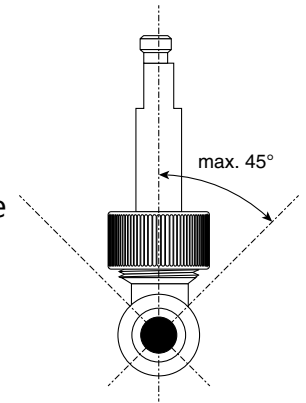

Step 1 DHW connectors are 1/2" FNPT. Using appropriate thread sealant and fittings, connect the water heater output to the input on the flow switch; and house hot water system to output on flow switch. The straight in- and outlet pipe (in front of and behind the flow switch) has to be at least 2-1/2" (65 mm).

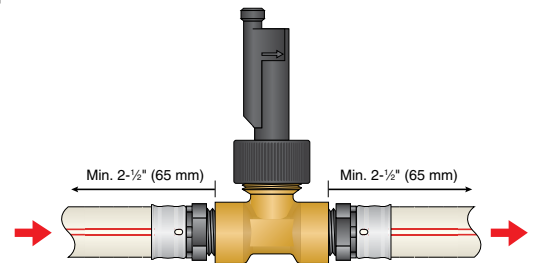

Step 2 Observe flow direction when making connections.

Step 3 Be sure to connect the DHW priority *downstream* from the panel (see schematic at right).

Step 4 Disconnect power from the panel. Remove the terminal header of the wiring harness from the flow switch. Connect the flow switch wires to the flow switch terminals.

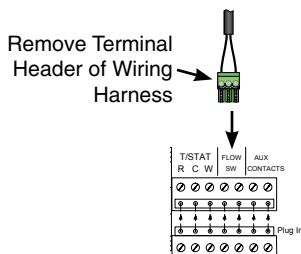
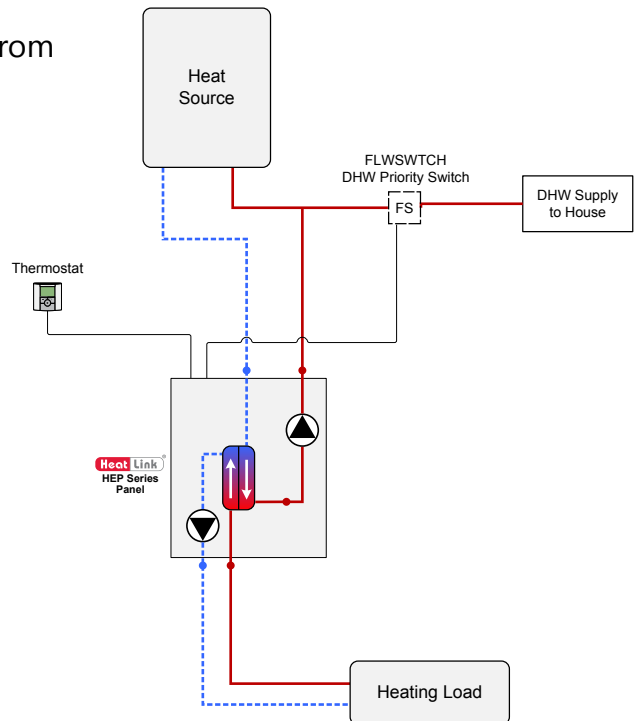

Troubleshooting

Problem	Check / Verify	Possible Cause
Low Temperature Within Room	Misplacement of thermostat location within room.	Make sure thermostat is not being influenced by an additional heat source, such as lighting or air duct.
	Low temperature setting of the thermostat.	Adjust the temperature setting on thermostat.
	The system fails to turn on if the thermostat is set to high setting	Thermostat may be out of calibration or defective. Replace thermostat.
	The electronic actuator fails to open during a call for heat	The electronic actuator may be improperly seated or may be defective. Replace if necessary.
	Wiring from heat source to panel.	Check that the wiring is done properly. Consult qualified electrician prior to alteration of wiring between heat source and panel.
	Output of heat source is unable to meet demand of heating system.	Compare output of heat source to the requirements of the heating system.
	Pump is not on during a call for heat. (Use a stethoscope or similar device to verify)	The wiring or pump may be defective.
	When zone valves are installed outside the panel a qualified electrician should verify 24V power is supplied to the thermostats and actuator.	The 24V transformer may have failed. Any zone valves must be opened manually to avoid dead-heading of the pump.
High Temperature Within Room	Check current setting of the thermostat.	Adjust the temperature setting on thermostat to a lower setting.
	Installed electronic actuators remain open after the thermostat is satisfied.	An obstruction inside the zone valve is not allowing the actuator to fully close or the thermostat is still calling for heat.

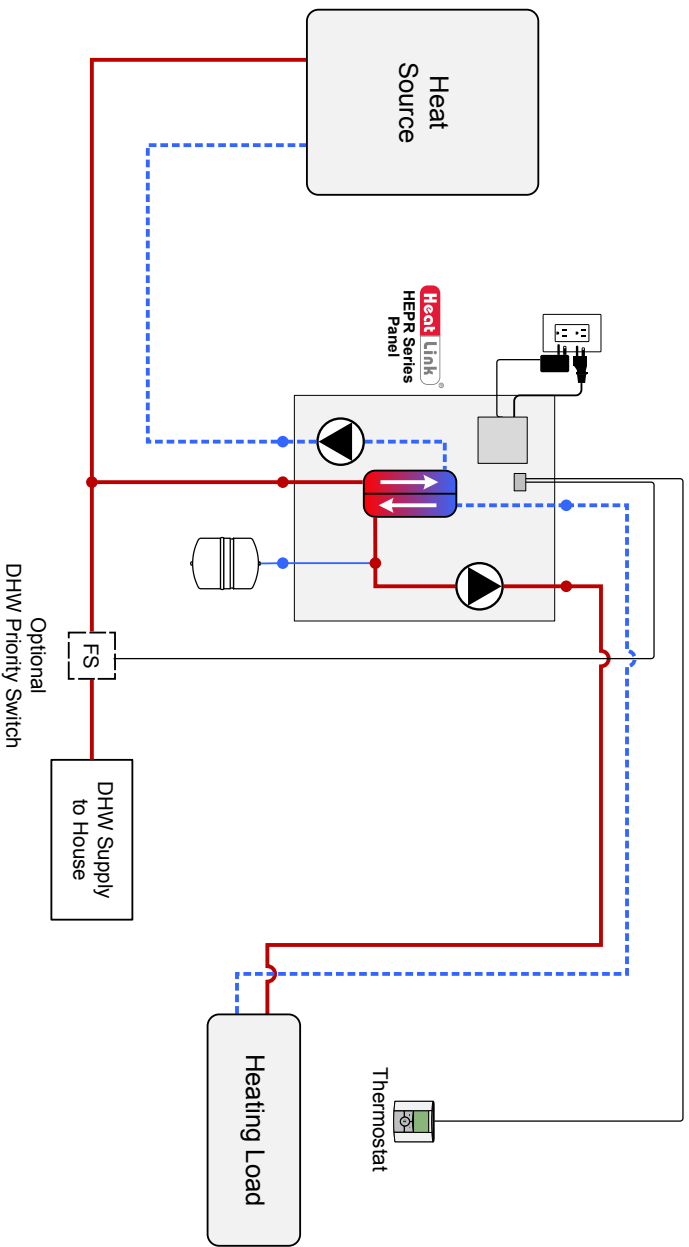

Heat Link[®]
 www.heatlink.com
 1-866-661-5332

- Notes:**
- Drawings are for HeatLink suggested system layout only! User must determine if system layout will work for their particular application.
 - Air Vents, expansion tanks, pressure relief valves, etc. for heat source as per local codes.
 - Use isolation ball valves for all circuits and components.
 - Local codes, regulations, and authorities have final jurisdiction.

Heat Source: Generic
 Panel(s): HEP Series
 Heat Load(s): Generic – Single Zone
 Date: 2017-05-11

Schematic #: **SCH-HEPR-M001**
 Rough-in wiring see: SCH-MRIB-R001
 Wiring detail see:

info@heatlink.com
www.heatlink.com