

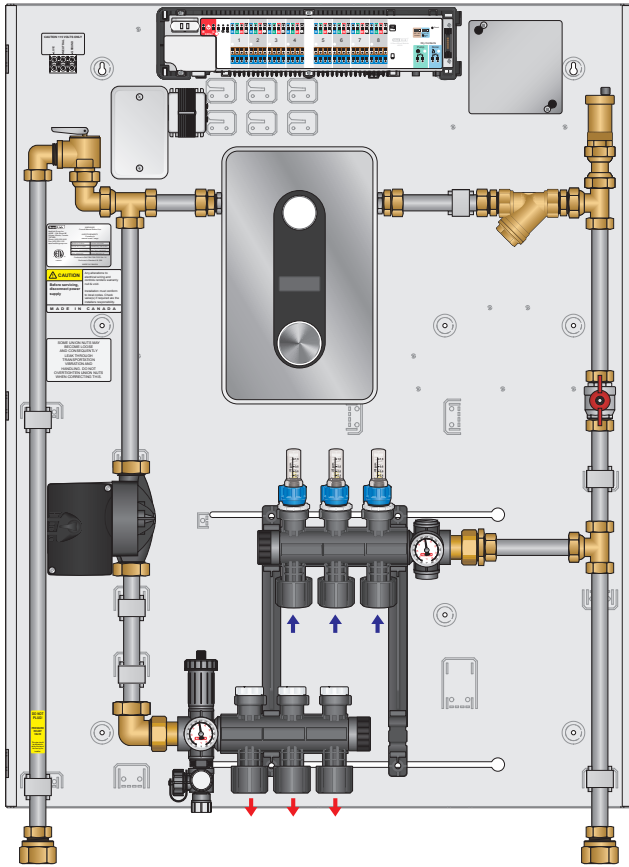

ELBPxxTSx Series

Installation, Operation, and Maintenance Manual

ELBP18TS3



ELBP50TS7

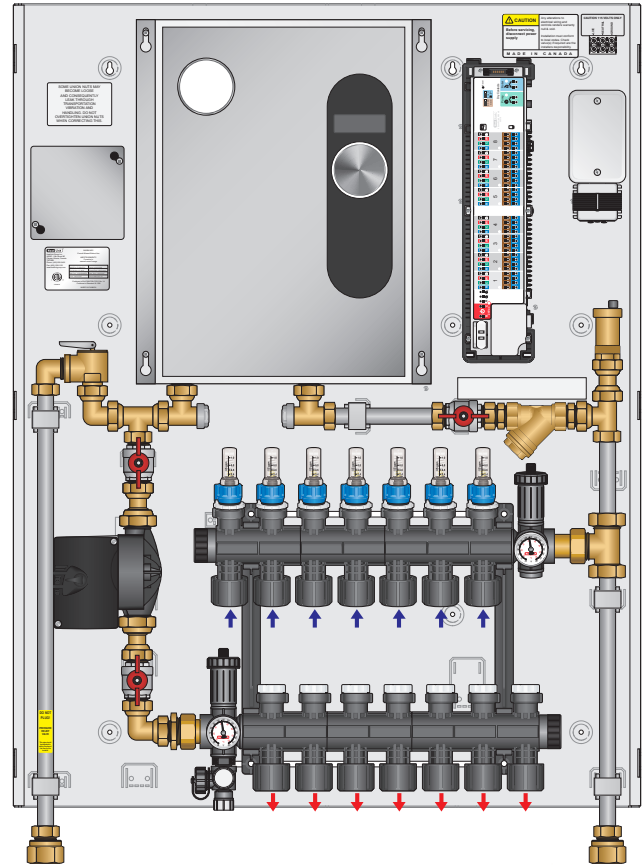

Table of Contents

Product Safety Information	2
Warnings	2
Servicing	2
Function	2
Unpacking	3
Unpacking	3
Installation Tools Needed	3
Panel Specifications	4
Panel Components (Diagram)	4
Dimensions	4
Panel Components	5
Specifications & Listings	6
Panel Installation	7
Panel Mounting	7
Piping Hookup	8
Piping Hookup (Diagram)	9
Fill & Purge	10
Panel Control Sequence & Wiring	12
Wiring Diagram	12
Troubleshooting	13

Disclaimer

HeatLink Group Inc. shall not be responsible for errors in its brochures or printed materials. HeatLink Group Inc. reserves the right to alter its products at any time without notice, provided that alterations to products already on order shall not require material changes in specifications previously agreed upon HeatLink Group Inc. and the Purchaser. All trademarks in this material are property of the respective companies. HeatLink and the HeatLink logotype are trademarks of HeatLink Group Inc. All rights reserved.

Product Safety Information

Warnings

The zone control panel is for indoor use only and must be installed by a qualified installer/service technician. This product must be installed and operated in strict accordance with the terms set out in this manual and in accordance with the relevant requirements of the Local Authority Having Jurisdiction. Failure to comply will result in a void of warranty, and may also result in property damage, serious injury, or death.

Servicing

Prior to commencing installation of this panel it is necessary to read and understand all sections of this manual. The symbols below are used throughout this document to ensure proper operation of the panel, and your safety. Please pay attention to these symbols.



Warning
Possible Hazard



Warning
Live Power



Warning
Hot Pipes



Warning
Treated Water



In order to avoid injury or death, switch off the power to the panel prior to inspecting or making connections to the terminal strip.

Function

This zone control panel can provide mixing, distribution, and zoning for a wide variety of hydronic heating applications.

The effectiveness of the system is dependant on the system being designed and installed correctly. Proper consideration of factors such as BTU loads, outdoor design temperature, indoor design temperature, room set-point temperature(s), differential fluid temperatures, head loss, flow rates, and transfer capacities of the heat emitters is critical.

Once these factors have been considered and the system requirements determined, these can then be evaluated and compared to the panel capabilities.

Note: For boiler operation see the boiler manual included with your ELBP panel.

Unpacking

Unpacking

- Step 1** Examine carton for any damage that may have occurred during shipping. If damage is visible notify your courier and supplier immediately.
- Step 2** Open the carton by removing the staples.
- Step 3** Remove the cardboard spacers from the carton, then remove the panel from the carton. Lift the panel by the base, not the enclosure.
- Step 4** There are two screws holding the cover to the backplate. Remove these with a Philips head screwdriver and put them aside.



This panel is heavy; 2-3 person lift required.

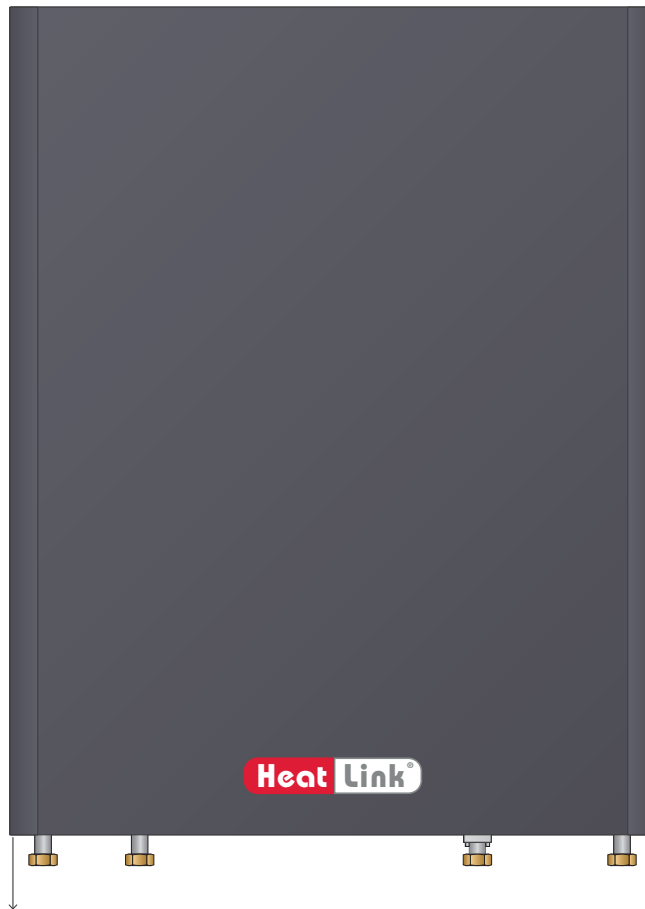

Installation Tools Needed

- Level
- Screwdriver or power drill
- Flat head bit
- Phillips head bit # 2
- 2 adjustable wrenches (or 2 × 30mm wrenches)

Panel Specifications

Panel Components (Diagram)

ELBP18TS3

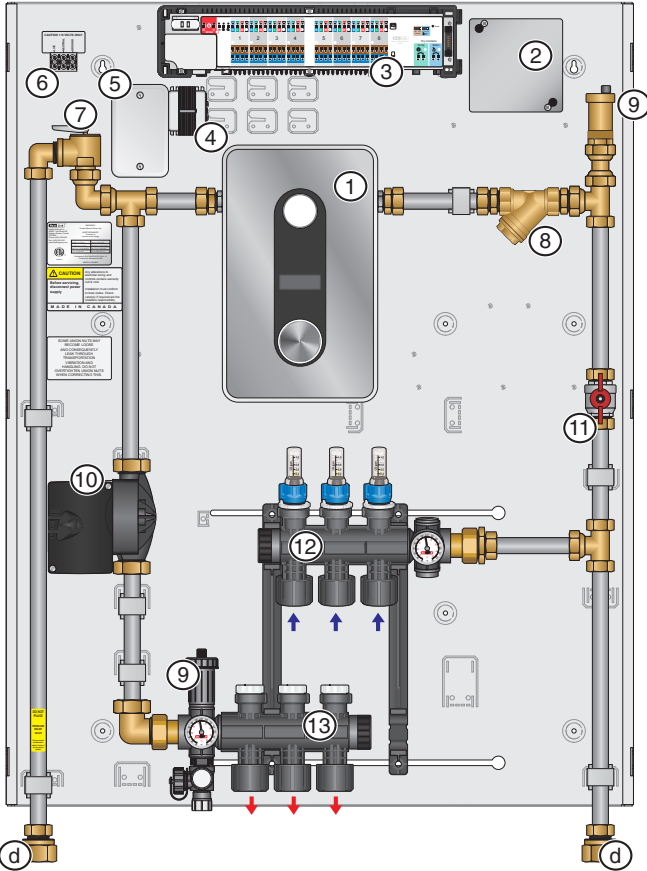

ELBP30TS5

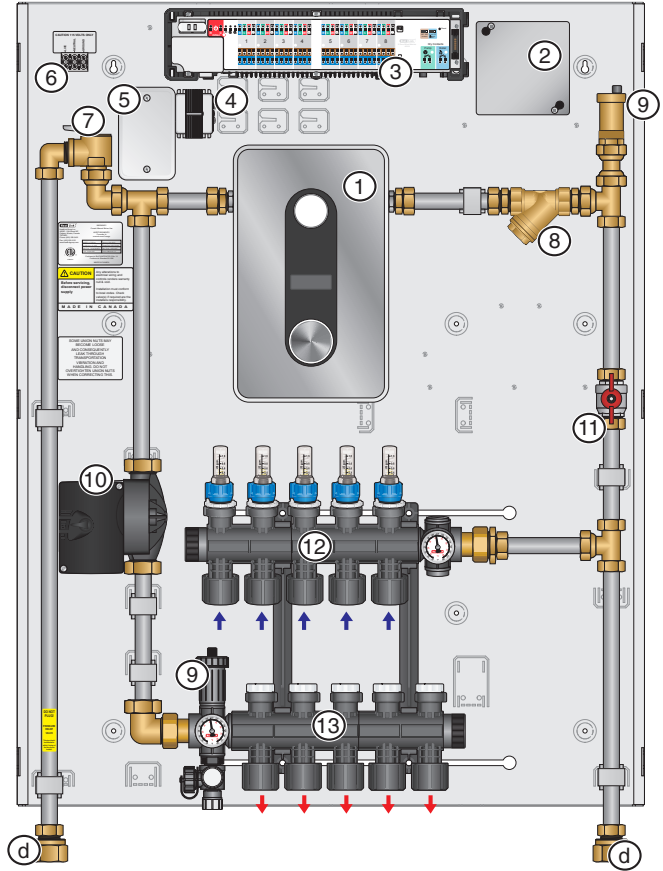

ELBP50TS7

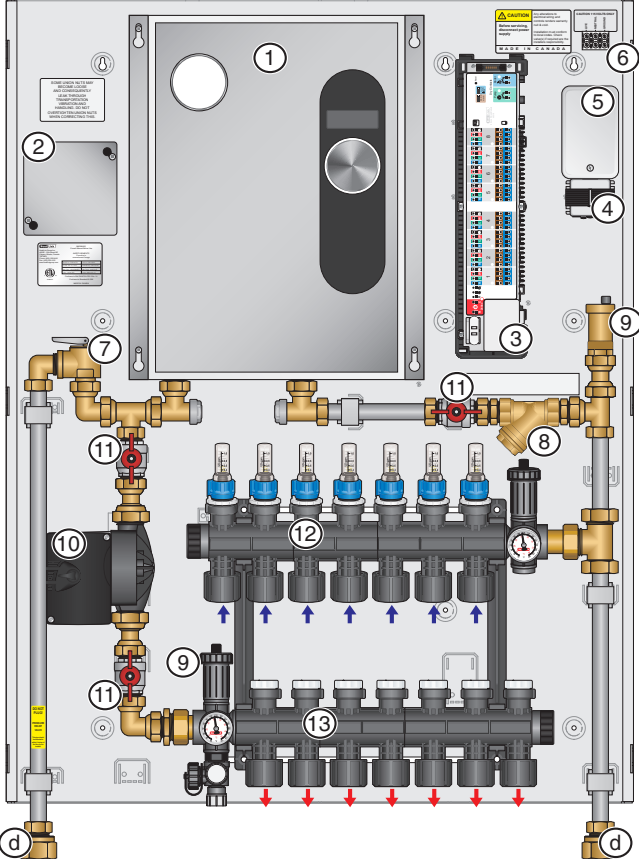

Dimensions

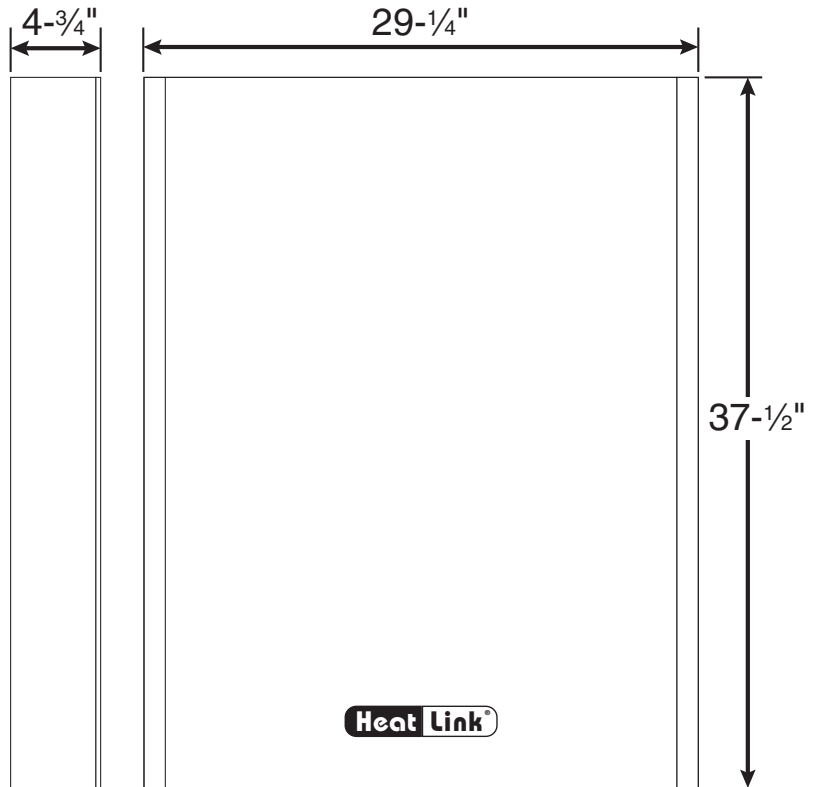

Panel Components

#	Components	Component Description	Part Number (Qty.)		
			ELBP18TSxx	ELBP30TSxx	ELBP50TSxx
1	Electric boiler	The electric boiler supplies hot water to the system, and is activated when there is a call for heat via a built in flow switch (see page xx for details). Requires 240V power source.	HA008240 (1)	HA011240 (1)	HA018240 (1)
2	Junction box	Wiring connection box for 240V	n/a	n/a	n/a
3	StatLink® 8 Zone Wired Module	Connects room thermostats to their corresponding actuators. Each zone has an LED which indicates a call for heat.		40318 (1)	
4	24Vac Transformer	Supplies 24V power to the StatLink®	(1)	(1)	(1)
5	Electrical box	Houses transformer wiring	(1)	(1)	(1)
6	Terminal strip	Field wiring connections	(1)	(1)	(1)
7	Pressure relief valve	Vents excess system pressure	(1)	(1)	(1)
8	Y strainer	Removes entrained air	(1)	(1)	(1)
9	Automatic air vent	Automatically vents entrained air	(1)	(1)	(1)
10	Pump	The circulator moves the heated fluid through the hydronic system when there is a call for heat from the thermostat. See pg 6 for pump curve.		PUMP1558 (1)	
11	Ball valve	Allows for panel isolation for fill & purge/maintenance	(1)	(1)	(3)
12	Return manifold	Modular TwistSeal® manifold for distribution to heating zones			
13	Supply manifold	Modular TwistSeal® manifold for distribution to heating zones			
14	Accessory pack	Installation Accessories		ACCELBP (1)	
a	1" nitrile washer	Spare washers for pump		NTRWSH1 (4)	
b	¾" nitrile washer	Washers for adapters, plus 2 spares for ball valves		NTRWSH34 (8)	
c	Mounting screw	Screws to mount panel to wall		(9)	
d	Piping adapters	¾"MSBP x 1"NPT Lead Free adapters		(2)	

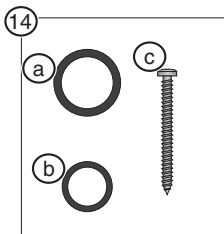

Specifications & Listings

Headings	ELBP18TSxx	ELBP30TSxx	ELBP50TSxx
Listing		cETLus	
Conforms to		CAN/CSA-C22 No.14, UL508	
Dimensions		37.5" W x 29.25" H x 4.75" D	
Weight			
Nominal panel output	18,000 BTU	30,000 BTU	50,000 BTU
Max ambient temperature		120°F	
Max water temperature			
Settable fluid temperature range		80-140°F	
Power supply 1		110 - 120V	
Power supply 2		210 - 240V	
Circulator		Non-ferrous Grundfos 15-58	
Piping		¾" Stainless steel tubing	
Piping connections		1" FNPT	
Backplate		Galvanized steel	
Enclosure		Powder coated steel	

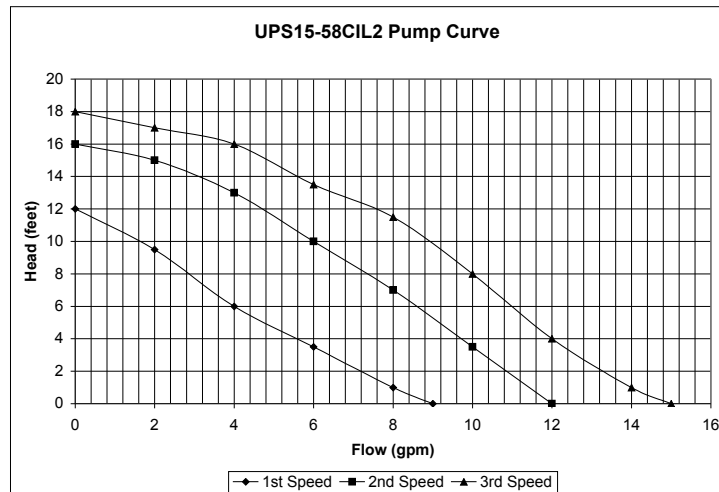

Panel Installation

Panel Mounting

Prior to mounting the panel, ensure the wall is capable of supporting the weight of the panel, and that the required 110V & 240V wiring is available at the installation location. See page xx for wiring details. The top of the panel should be a minimum of 5 feet from the floor, with sufficient space left at the bottom for required piping.

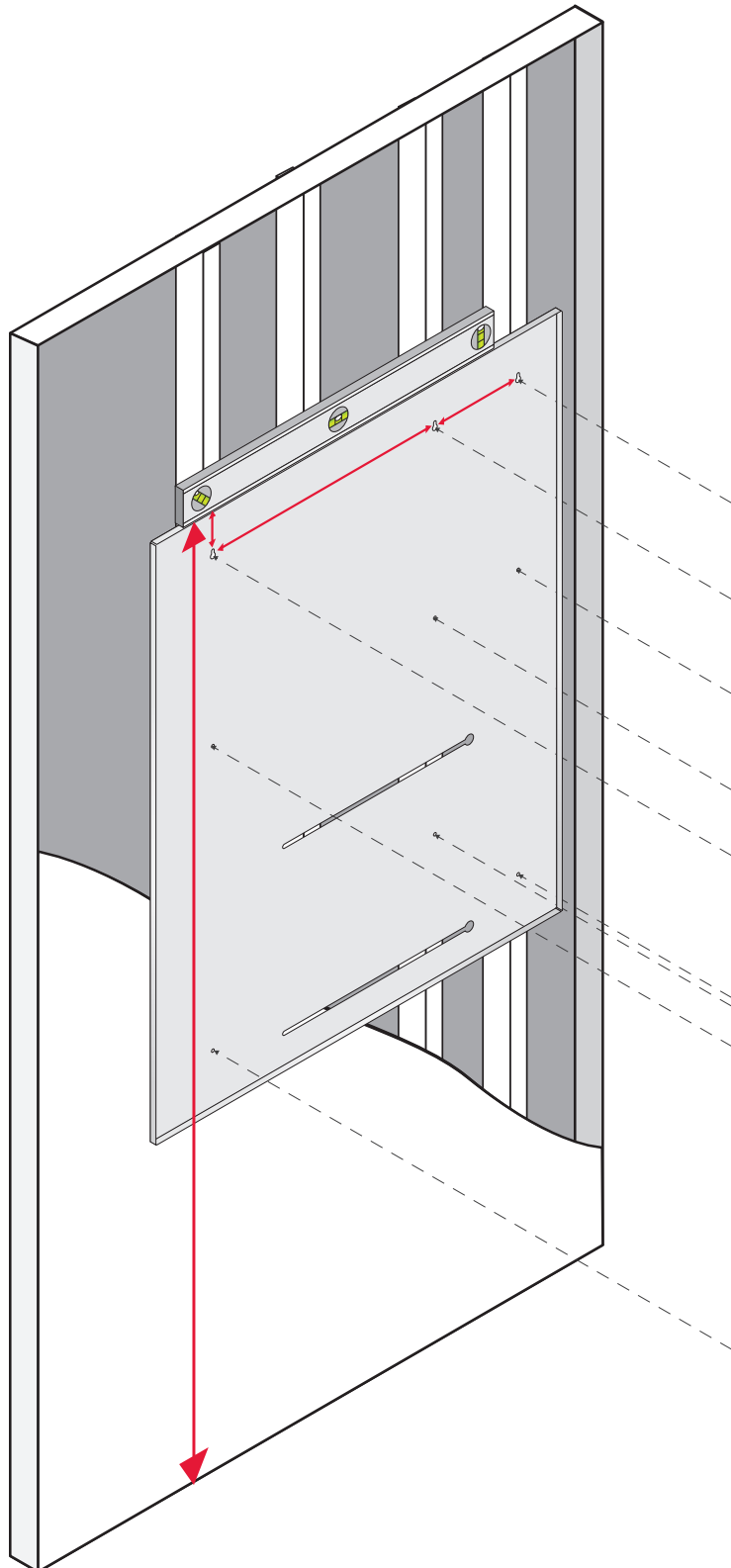

- Step 1** Using a level at the minimum height of 5 feet, draw a straight line on the wall.
- Step 2** Mark stud locations. *If the panel cannot be secured directly to the studs, a backing board may be needed to properly install the panel.*
- Step 3** Screw three of the supplied mounting screws into the studs or backing board 3" from the desired height, 6" and 16" apart (see diagram).
- Step 4** Lift and place the panel onto the mounting screws using the keyhole slots.
- Step 5** Screw the remaining mounting screws into place, and tighten all screws.
- Step 6** Refer to piping hookup, fill and purge, and wiring instructions before replacing the cover.

Piping Hookup

- Step 1** Identify the piping connections on the panel. *You will need 2x 30mm, or large adjustable or smooth jaw pipe wrenches to tighten the fittings.*
- Step 2** Ensure that the panel is mounted in the correct position
- Step 3** Connect the 2 adapters to the supply and return piping on the panel, using the supplied washers. Do not overtighten the panel connections, as this will damage the rubber washers.
- Step 4** Attach the PEX tubing to the manifold connection using #77000 series connectors (not included).

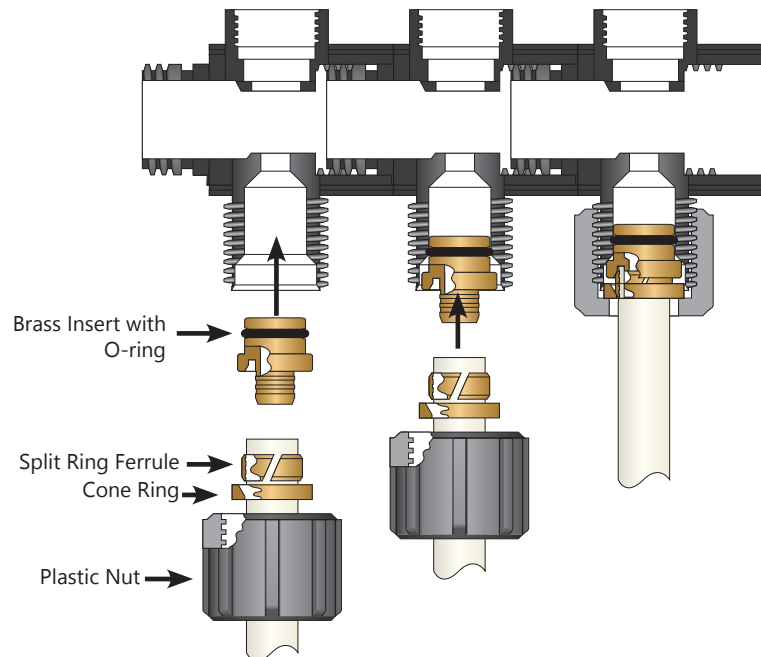
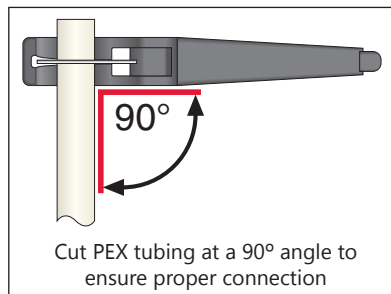

- Step 5** Remove the plastic manifold nut.
- Step 6** Lubricate the inside of the manifold port with silicone o-ring lubricant (#79952).
- Step 7** Cut the PEX tubing at a 90° angle.
- Step 8** Place the plastic manifold nut, cone ring, and split ring ferrule onto the PEX tubing (the bevelled edge of the cone ring must be facing the split ring ferrule).
- Step 9** Method A
- Push the brass insert onto the PEX tubing as far as it will go.
 - Push the PEX tubing with the brass insert as far as it will go into the manifold. Ensure that the o-ring is clean and take care not to pinch it.
- Step 10** Method B
- Push brass insert as far as it will go into the manifold. Ensure the o-ring is clean and take care not to pinch it.
 - Push PEX tubing onto the brass insert as far as it will go.
- Step 11** Use the multi-purpose wrench to tighten the nut.

Piping Hookup (Diagram)

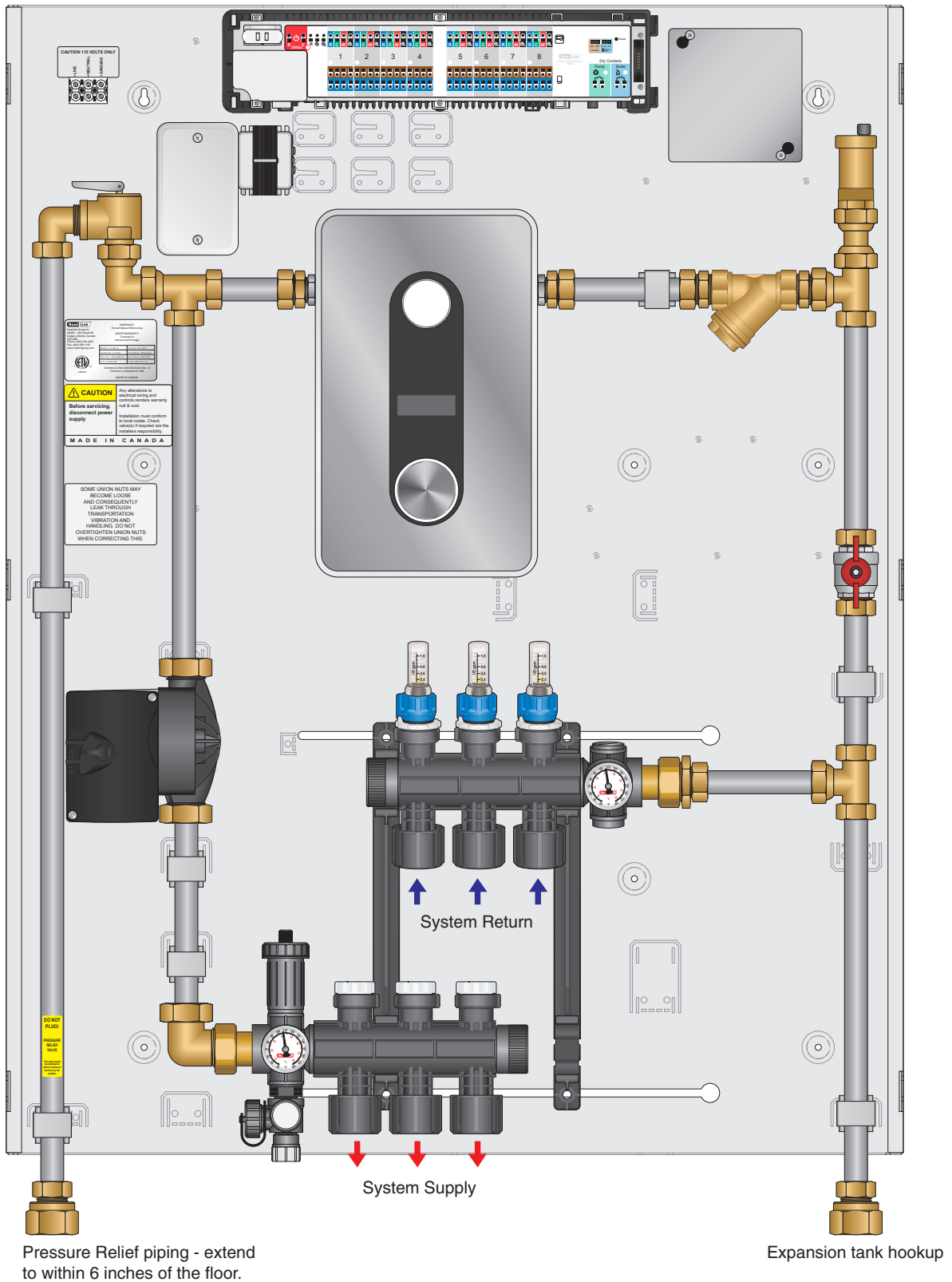

Fill & Purge

The following steps are recommended in order to fill the panel with water and purge entrained air once piping is completed, and before activation of the panel.

Note: Additional purging steps may be required for the rest of the system.



The discharged system fluid from the fill and purge process is not for consumption or washing.

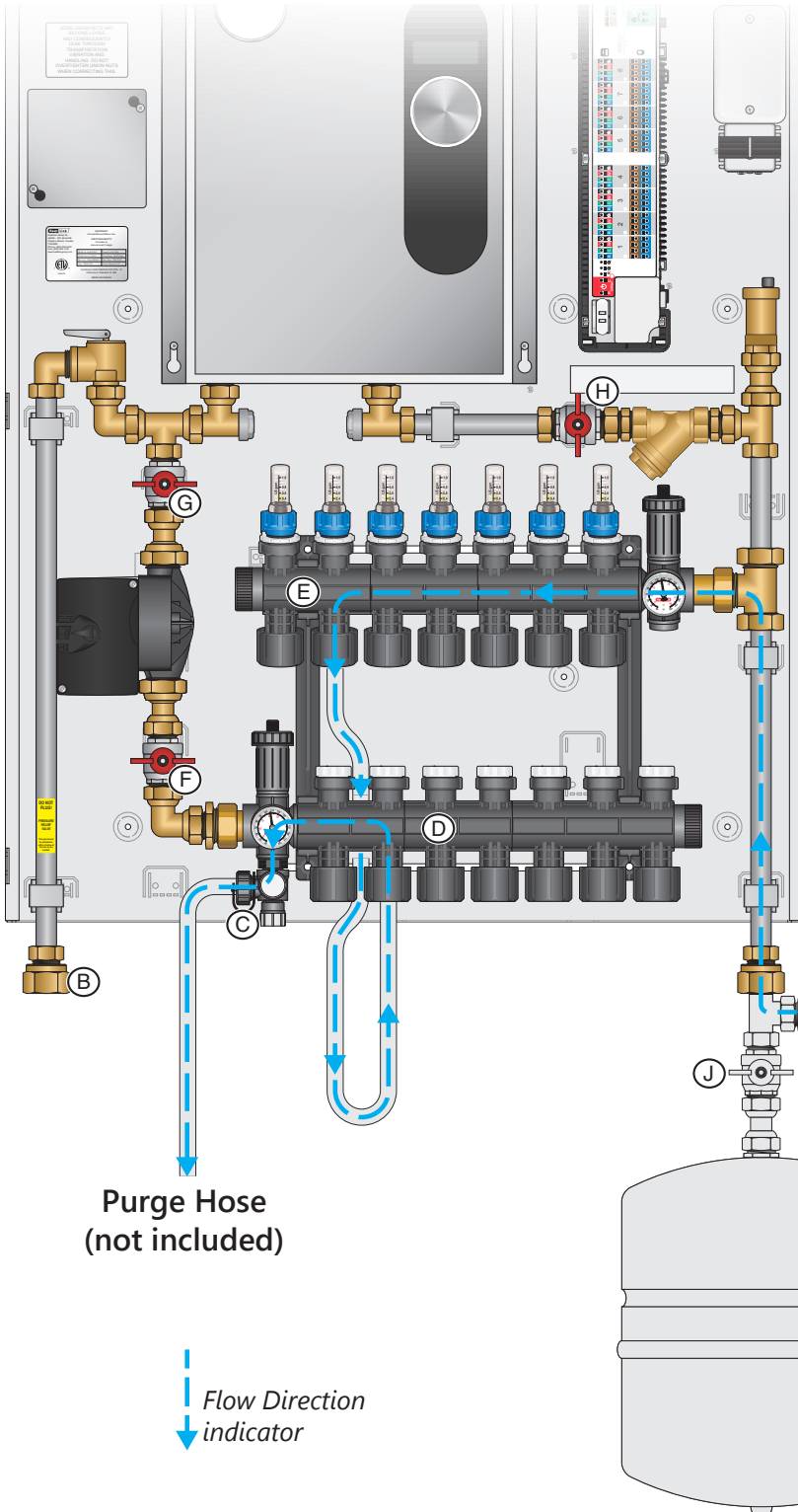

- Step 1** Ensure the panel is **not** powered.
- Step 2** Close valve J, or ensure expansion tank piping is closed/plugged.
- Step 3** Fully close valves A, C, F, G, H. Plug pressure relief valve B for fill and purge only.
- Step 4** Fully close all Supply D and Return E manifold valves.
- Step 5** Attach purge hose (not included) to C; run hose to bucket or drain.
- Step 6** Attach fill hose (not included) to A.
- Step 7** Open first Return manifold E valve, and first Supply manifold D valve.
- Step 8** Open valves C and A.
- Step 9** Watch the purge hose in the pail until you observe a steady stream of water (no air or spitting).
- Step 10** Close the first Return manifold E valve and the first Supply manifold D valve.
- Step 11** Repeat for each loop in the system.

Fill Hose
(not included)

Purge Hose
(not included)

Flow Direction
indicator

Step 12 Once each loop has been filled, close all supply and return manifold valves.

Step 13 Open valves F, G, H.

Step 14 Watch the purge hose in the pail until you observe a steady stream of water (no air or spitting).

Step 15 Open valve J.

Step 16 Close valve C.

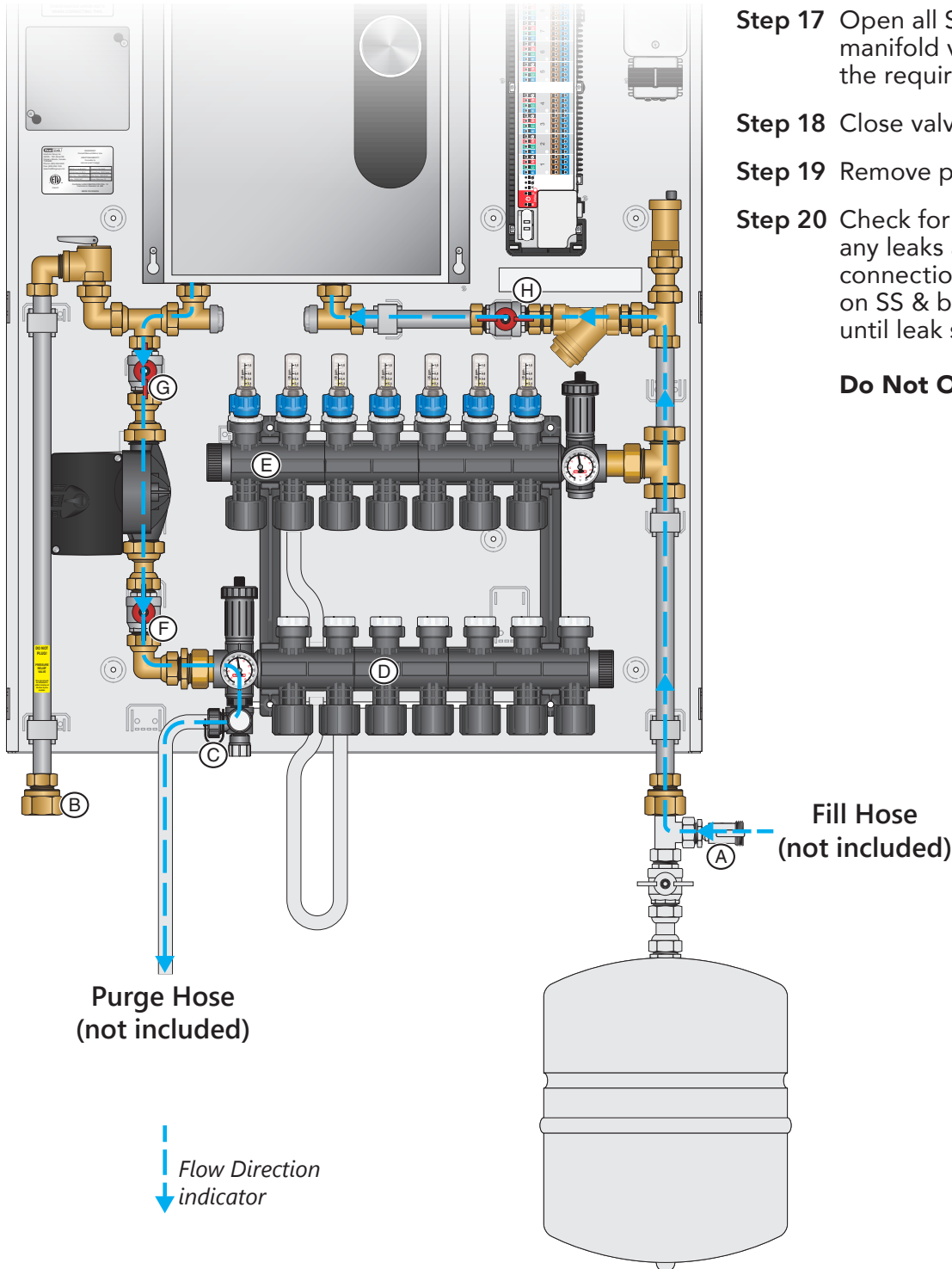

Step 17 Open all Supply D and Return E manifold valves; fill the system to the required operating pressure.

Step 18 Close valve A.

Step 19 Remove plug from B.

Step 20 Check for leaks at connections. If any leaks are found, tighten the connection (using a backup wrench on SS & brass connections) slowly until leak stops.

Do Not Overtighten.

Thermostat & Actuator Wiring

Step 1 Remove the plastic cover. Open (and close) the four white screws with a quarter turn only. Note that screws on opposite sides turn in the opposite direction.

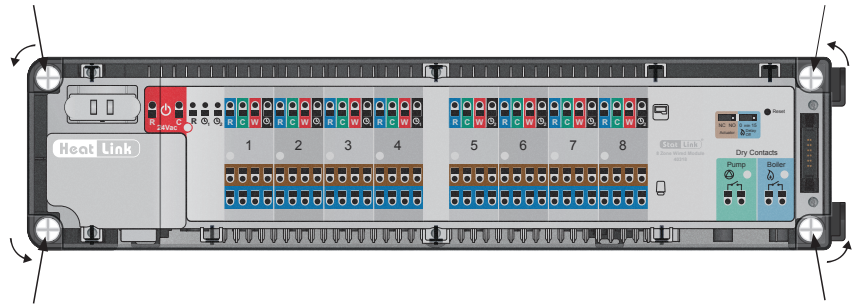

Step 2 Remove the white terminal connection board by removing the six screws shown below. Take precautions not to remove the 24V power cable, or the pump and boiler cables.

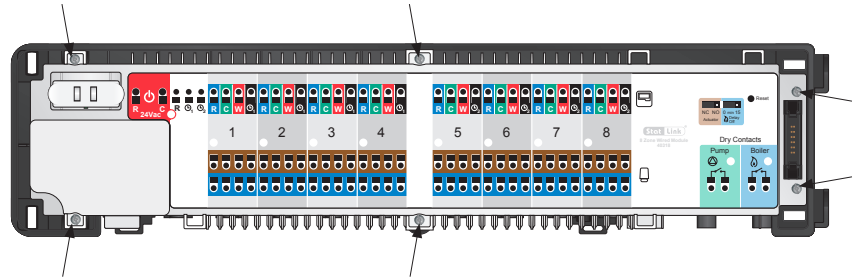

Step 3 Cut the thermostat, and actuator cables to length.

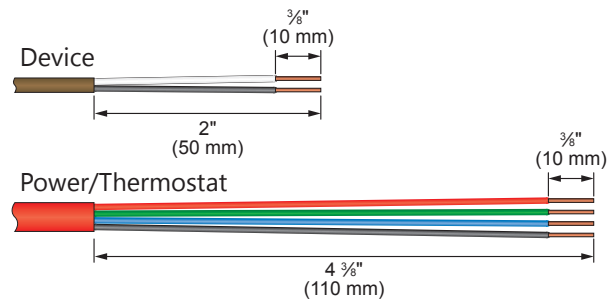

Step 4 Clip all power and thermostat cables into their correct positions. The following shows the power, zone 1, and 2 thermostat cables in position:

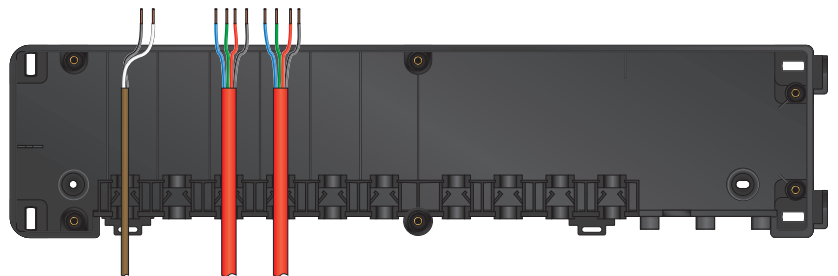

Step 5 Replace the white terminal connection board.

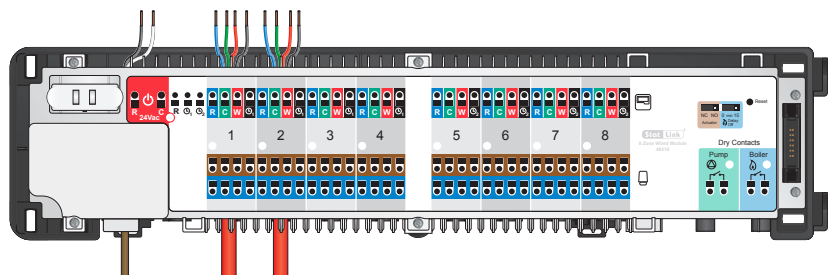

Step 6 Bend over and push all thermostat wires into the round holes at the top of the module.

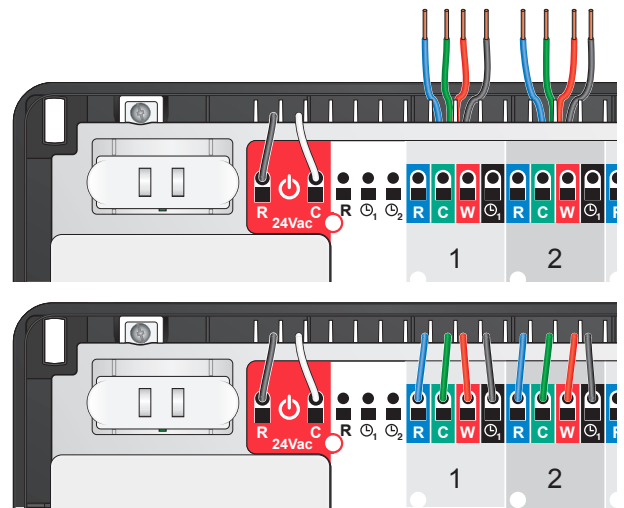

Step 7 Push the actuator wires into the round holes at the bottom of the module. Clip wires into the strain relief. You can connect up to four actuators in each zone.

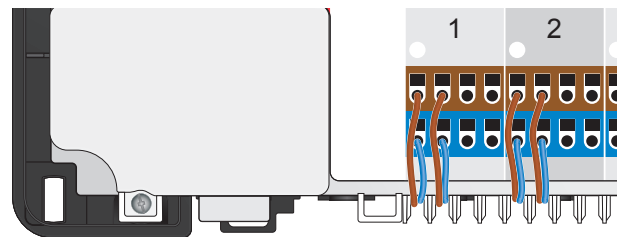

Step 8 Replace the plastic cover.

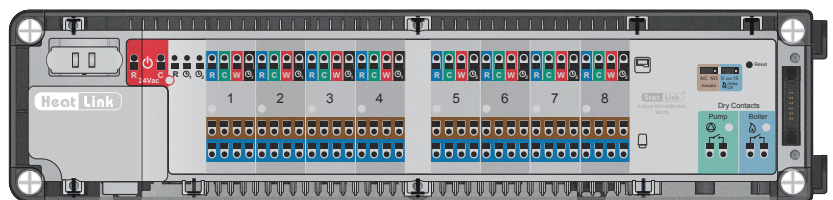

Step 9 Switch on mains power supply to the unit. The red LED comes on.

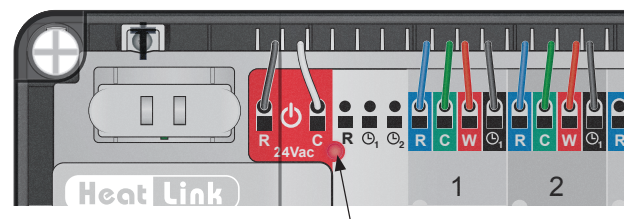

40318 LED Indications

Power	● red	40318 is supplied with 24Vac
Zone 1 Actuator(s)	● green	Demand from zone 1 thermostat: actuator open
Zone 2 Actuator(s)	● green	Demand from zone 2 thermostat: actuator open
Zone 3 Actuator(s)	● green	Demand from zone 3 thermostat: actuator open
Zone 4 Actuator(s)	● green	Demand from zone 4 thermostat: actuator open
Zone 5 Actuator(s)	● green	Demand from zone 5 thermostat: actuator open
Zone 6 Actuator(s)	● green	Demand from zone 6 thermostat: actuator open
Zone 7 Actuator(s)	● green	Demand from zone 7 thermostat: actuator open
Zone 8 Actuator(s)	● green	Demand from zone 8 thermostat: actuator open
Pump	● red	Pump is on
Boiler	● red	Boiler is on

Note: the reset button is to the right of the boiler delay jumpers. Using a suitable tool, press this button at any time to power cycle the module.

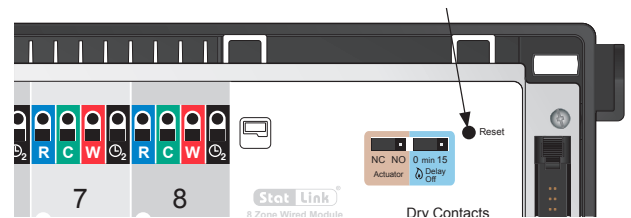

Panel Control Sequence & Wiring

Two (2) Double Pole 50 Amp circuit breakers must be installed in the main electrical panel.

All wiring should be done by a qualified electrician, and should meet local codes and jurisdictions.

HeatLink® ELBP panels require two (2) separate power sources: 120V to power the pump, and via the 24Vac transformer, the StatLink®, and actuators (optional, sold separately); and 240V to power the electric boiler. Both power sources must be connected for the ELBP panel to function properly. Refer to the wiring diagram below.

When there is a call for heat from the thermostats wired to the StatLink® 8 Zone Wired Module, a relay is switched on, activating the pump; the electric boiler is then activated via a flow meter and supplies heat based on the user settings.

Note: A timer thermostat (46645) can send a setback signal to other thermostats via terminal Clock 1 or 2.

Wiring Diagram

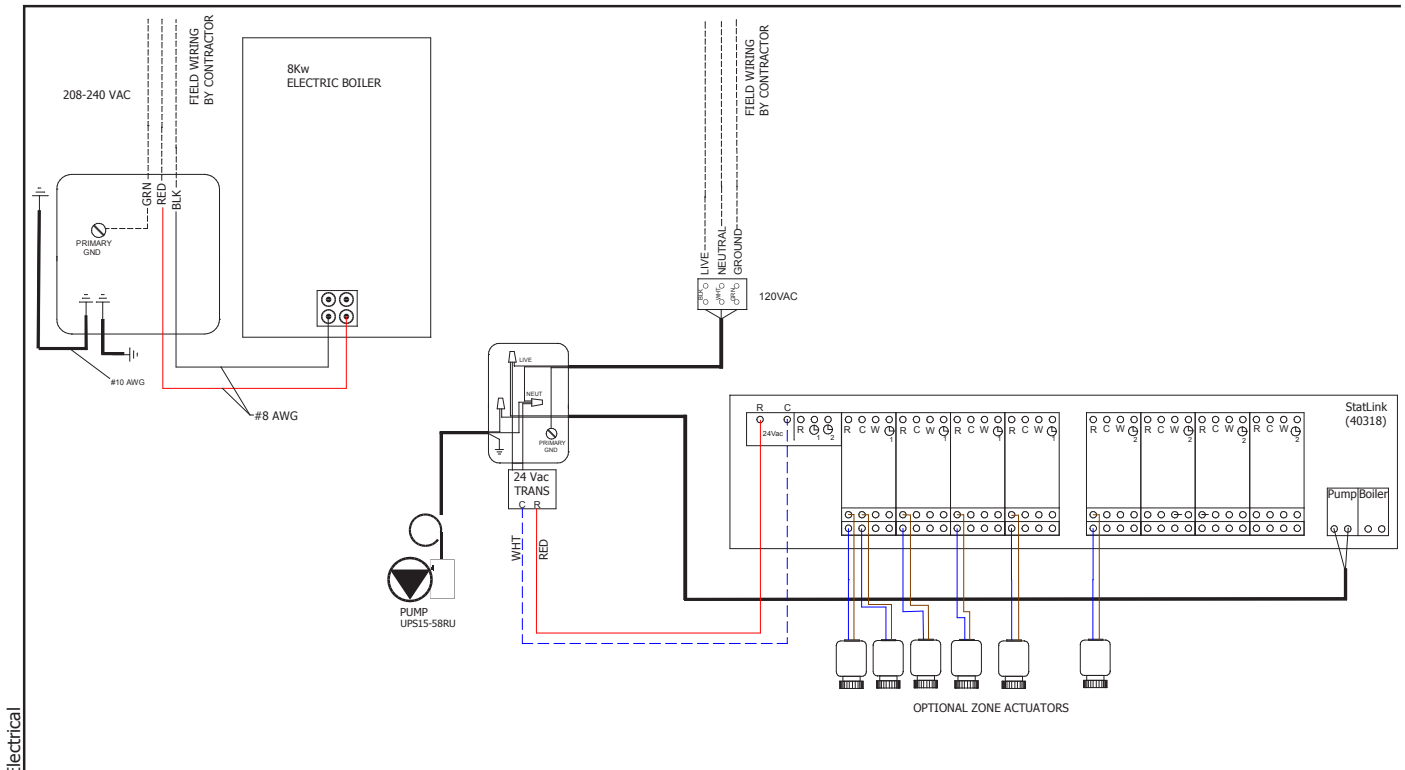

DesignSpark Electrical

ELBP - 8 kW

CONTRACT:	LOCATION: L1	Main electrical closet	REVISION
			0
REV. 0	DATE 11/01/2019	NAME jsinclair	SCHEME
CHANGES			03
User data 1		User data 2	

Document created with version: 2018.0.3.20

Troubleshooting

Problem	Check / Verify	Possible Cause
Low temperature within room	Misplacement of thermostat location within room.	Make sure thermostat is not being influenced by an additional heat source, such as lighting or air duct.
	Low temperature setting of the thermostat.	Adjust the temperature setting on thermostat.
	The system fails to turn on if the thermostat is set to high setting	Thermostat may be out of calibration or defective. Replace thermostat.
	The electronic actuator fails to open during a call for heat	The electronic actuator may be improperly seated or may be defective. Replace if necessary.
	Low supply mixed fluid temperature.	Voltage supplied to Electric Boiler may be less than 240 volts, causing the boiler to read the water temperature as slightly higher than it actually is. Increase the setting on your boiler to compensate.
	Wiring from heat source to panel.	Check that the wiring is done properly. Consult qualified electrician prior to alteration of wiring between heat source and panel.
	Output of heat source is unable to meet demand of heating system.	Compare output of heat source to the requirements of the heating system.
	The user setting may be too low.	Turn up the user setting on the electric boiler.
	Circulator is not on during a call for heat. (Use a stethoscope or similar device to verify)	Check that the wiring is done properly. Consult qualified electrician prior to alteration of wiring between pump and electrical box.
When zone valves are installed outside the panel a qualified electrician should verify 24V power is supplied to the thermostats and actuator.	The 24V transformer may have failed. If this so, switch the power module to Bypass mode. This will provide constant circulation so long as there is still 110V power to the panel. Prior to Bypass mode selection, any zone valves must be opened manually to avoid dead-heading of the circulator.	
High Temperature within Room	Check current setting of the thermostat.	Adjust the temperature setting on thermostat to a lower setting.
	High supply mixed fluid temperature.	Adjust the Thermostatic Mixing Valve to the appropriate settings.
	Installed electronic actuators remain open after the thermostat is satisfied.	An obstruction inside the zone valve is not allowing the actuator to fully close or the thermostat is still calling for heat.
Low Water Temperature	Check current setting of the aquastat.	Adjust the temperature setting on aquastat to a higher setting.
	Circulator is not on during a call for heat. (Use a stethoscope or similar device to verify)	The power box or circulator may be defective.
	The red and green LED's on the power module do not light up during a call for heat.	The power box may be defective.
High Water Temperature	Check current setting of the aquastat.	Adjust the temperature setting on aquastat to a lower setting.

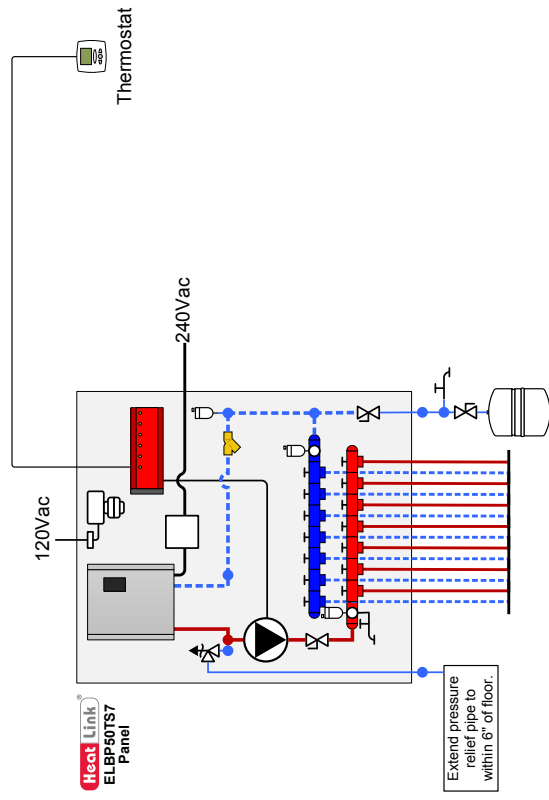

Notes:

- Drawings are for HeatLink suggested system layout only! User must determine if system layout will work for their particular application.
- Air vents, expansion tanks, pressure relief valves, etc. for heat source as per local codes.
- Use isolation ball valves for all circuits and components.
- Local codes, regulations, and authorities have final jurisdiction.

Heat Source: Electric Boiler
Panel(s): ELBP30TS3, ELBP30TS5, ELBP50TS7
Heat Load(s): Radiant Heating – Single Zone

Date: 2014-05-15

Schematic #: SCH-ELBP-M002

Rough-in wiring see: SCH-MRIB-R001

Wiring detail see: SCH-ELBP-E001

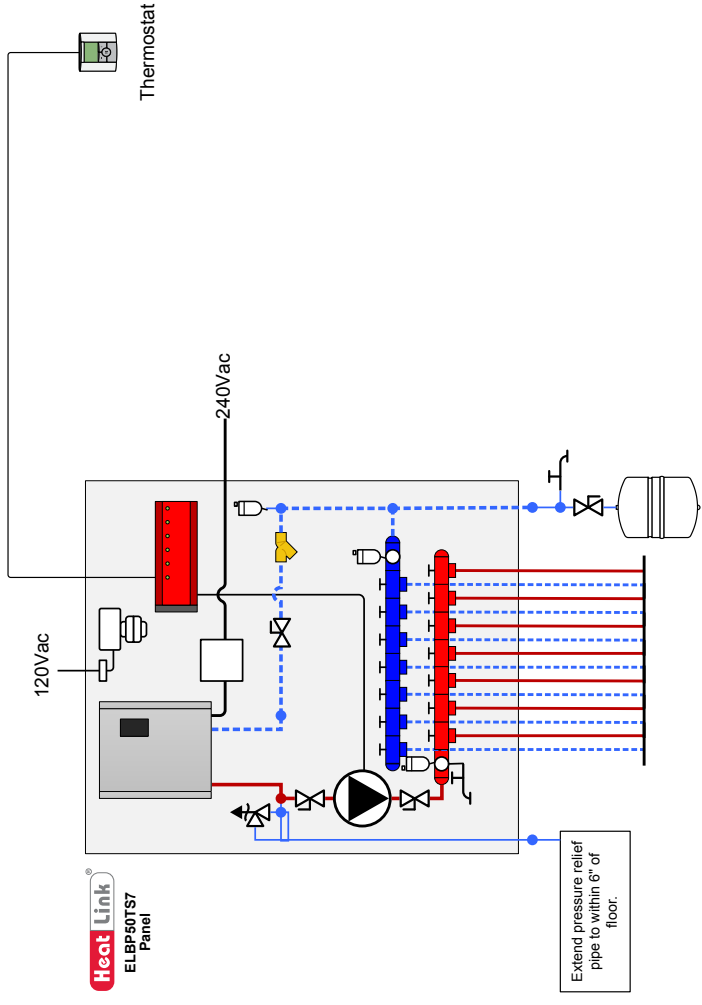

Heat Link
 www.heatlink.com
 1-866-661-5332

Notes:

- Drawings are for HeatLink suggested system layout only! User must determine if system layout will work for their particular application.
- Air vents, expansion tanks, pressure relief valves, etc. for heat source as per local codes.
- Use proper ball valves for all circuits and components.
- Local codes, regulations, and authorities have final jurisdiction.

Heat Source: Electric Boiler
Panel(s): ELBP30TS3, ELBP30TS5, ELBP50TS7
Heat Load(s): Radiant Heating – Single Zone
Date: 2017-04-28

Schematic #: SCH-ELBP-M004
Rough-in wiring see: SCH-MRIB-R001
Wiring detail see: SCH-ELBP-E001



Heat Link[®] Canada

Manufactured & distributed by HeatLink Group Inc.

Head Office:

4603E - 13th Street N.E.
Calgary, Alberta, T2E 6M3

Toll Free: 1-800-661-5332
International Phone: +1 (403) 250-3432
Fax: 1-866-450-1155

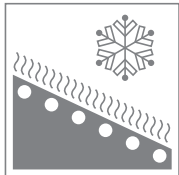

Heat Link[®] China

Distributed by Cathay-Links International

Phone: 852-25693213
Fax: 852-25359271

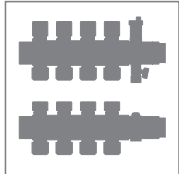

Heat Link[®] Ireland

Distributed by Jamoni Ltd.

Phone: 057 - 932 4062
Fax: 057 - 932 4063
Freephone: 1800-311338

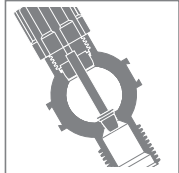

Heat Link[®] México

Distributed by Distribuidora Caisa S.A. de C.V.

Phone: (52-55) 3300-4400
Fax: (52-55) 3300-4406

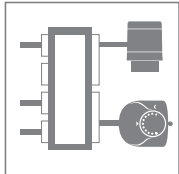

Heat Link[®] United States

Distributed by HeatLink Group Inc.

USA Distribution Center:

1000 - 100th Street SW, Suite B
Byron Center, MI, 49315

Toll Free: 1-800-661-5332
Fax: 1-800-869-6098



info@heatlink.com
www.heatlink.com