

Table Of Contents

Warnings.....	3
Servicing.....	3
Disclaimer.....	3
Tools For Installation.....	3
Function.....	4
Unpacking.....	4
Panel Components.....	5
Specifications.....	6
Panel Component Specifications.....	7
Circulators.....	7
Mounting.....	8
Piping Hookup.....	9
Fill And Purge.....	10
Panel Wiring.....	11
CAD01 Panel Control Sequence & Wiring.....	12
CAD02 Panel Control Sequence & Wiring.....	13
Troubleshooting.....	14
Maintenance.....	15
Schematics.....	16-19

Warnings

The CAD panel is for indoor use only and must be installed by a qualified installer/service technician. This product must be installed and operated in strict accordance with the terms set out in this manual and in accordance with the relevant requirements of the Local Authority Having Jurisdiction. Failure to comply will result in a void of warranty, and may also result in property damage, serious injury, or death.

Servicing

Prior to commencing installation of this panel it is necessary to read and understand all sections of this manual. The symbols below are used throughout this document to ensure proper operation of the panel, and your safety. Please pay attention to these symbols.



Warning
Possible Hazard



Warning
Live Power



Warning
Hot Pipes



Warning
Treated Water



In order to avoid injury or death, switch off the power to the panel prior to inspecting or making connections to the terminal strip.

Disclaimer

HeatLink Group Inc. shall not be responsible for errors in its brochures or printed materials. HeatLink Group Inc. reserves the right to alter its products at any time without notice, provided that alterations to products already on order shall not require material changes in specifications previously agreed upon HeatLink Group Inc. and the Purchaser. All trademarks in this material are property of the respective companies. HeatLink and the HeatLink logotype are trademarks of HeatLink Group Inc. All rights reserved.

Tools For Installation

- Level
- Screwdriver or power drill
- Flat head bit
- Phillips head bit # 2
- 2 adjustable wrenches (or 2× 30mm wrenches and 2× 40mm wrenches)

Function

This panel is specially designed to work with the Cadet boiler and can provide distribution and zoning for a wide variety of hydronic heating applications.

The effectiveness of the system is dependant on the system being designed and installed correctly.

Proper consideration of factors such as BTU loads, outdoor design temperature, indoor design temperature, room set-point temperature(s), differential fluid temperatures, head loss, flow rates, and transfer capacities of the heat emitters is critical.

Once these factors have been considered and the system requirements determined, these can then be evaluated and compared to the zone control panel capabilities (refer to pages 5-8).

Note: This panel does not regulate or monitor the operating safety limit temperatures of the fluid leaving the heat source.

Unpacking

Step 1 Examine carton for any damage that may have occurred during shipping. If damage is visible notify your courier and supplier immediately.

Step 2 Open the carton by removing the staples.

Step 3 Remove the cardboard spacers from the carton, then remove the panel from the carton. Lift the panel by the base, not the cover.

Step 4 There are 4 screws holding the cover in place. Remove these 4 screws.

Step 5 Remove the cover from the panel.



Step 6 Verify the following items:

- Installation, Operation and Maintenance Manual
- Accessory Pack (see next page for details)

Panel Components

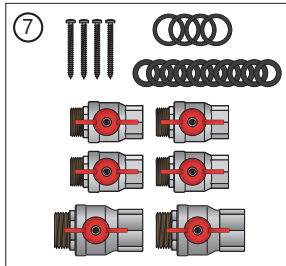
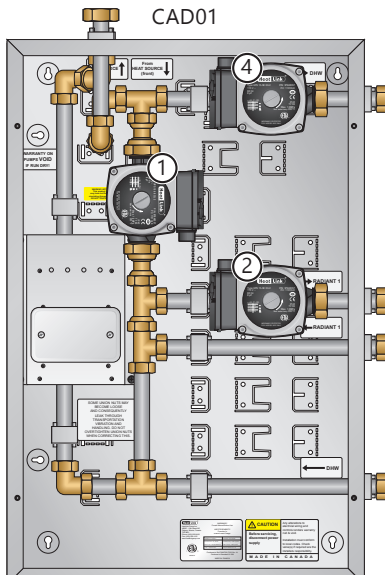

- (4) mounting screws
- (10) 3/4" rubber washers
- (4) 1" rubber washers
- (4) 3/4" M G x 3/4" FNPT Ball Valves
- (2) 1" M G x 1" FNPT Ball Valves

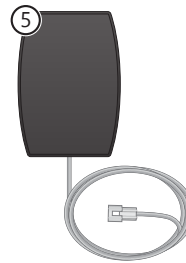
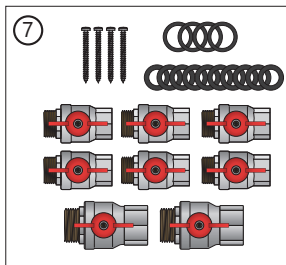
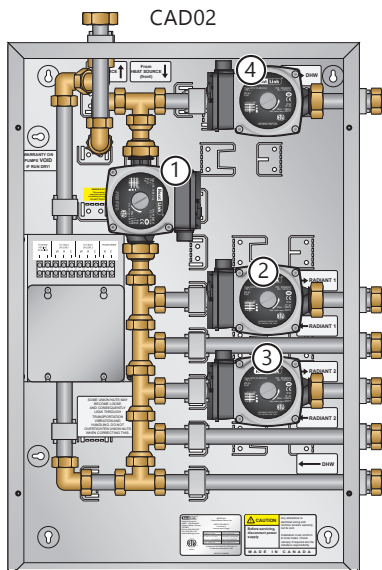

- (4) mounting screws
- (12) 3/4" rubber washers
- (4) 1" rubber washers
- (6) 3/4" M G x 3/4" FNPT Ball Valves
- (2) 1" M G x 1" FNPT Ball Valves

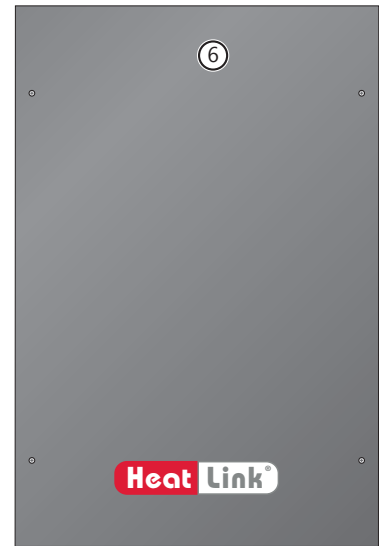

#	Component	Part Number	
		CAD01	CAD02
①	Primary Circulator	PUMP1558	PUMP1558
②	Radiant 1 Circulator	PUMP1558	PUMP1558
③	Radiant 2 Circulator	n/a	PUMP1558
④	DHW Circulator	PUMP1558	PUMP1558
⑤	40VA Plug-in Transformer	n/a	PLINTR40VA
⑥	Enclosure	n/a	n/a
⑦	Accessory Pack	-	-
	3/4" Washer	NTRWSH34	NTRWSH34
	1" Washer	NTRWSH1	NTRWSH1

Specifications

	CAD01	CAD02
Listing	cETLus	
Conforms to	CAN/CSA-C22 No.14, UL508	
Dimensions	26.566"H x 17.609"W x 7.628"D	
Nominal panel output	80,000 btu/hr	100,000 btu/hr
Nominal flow	6.0 US gpm @ 35°F ΔT	10.0 US gpm @ 35°F ΔT
Max ambient temperature	120°F (49°C)	
Min operating temperature	40°F (4°C)	
Max operating temperature	200°F (93°C)	
Max operating pressure	125 psi (862 kPa)	
Power requirements	120 V(ac)/24 V(ac) 60 Hz	
Primary circulator	Non-ferrous, Grundfos UPS15-58	
Radiant 1 circulator	Non-ferrous, Grundfos UPS15-58	
Radiant 2 circulator	n/a	Non-ferrous, Grundfos UPS15-58
DHW circulator	Non-ferrous, Grundfos UPS15-58	
Auxiliary terminal	n/a	1 dry contact, max. load 1.5A
Piping	3/4" 304 Stainless steel tubing	
Piping connections	1" MNPT	
Backplate	16 gauge galvanized steel	
Enclosure	Powder coated steel	

Panel Component Specifications

Circulators

The circulators moves the heated fluid through the hydronic system when there is a call for heat from the thermostat.

Specifications:

- The following pump curves apply.

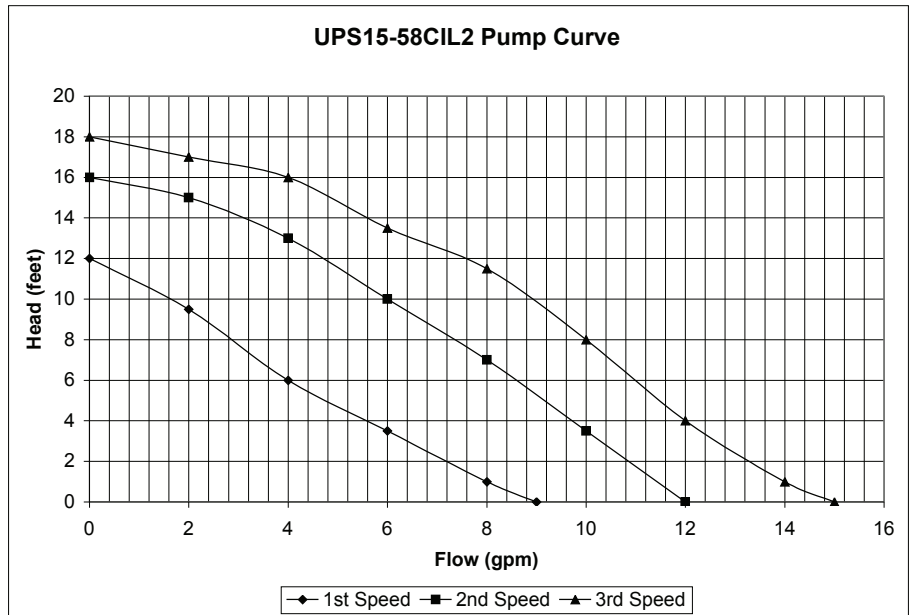
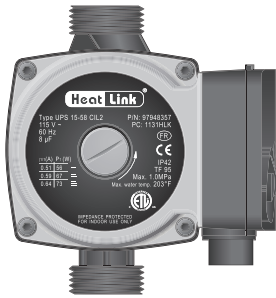

Mounting

Prior to mounting the panel, ensure the wall is capable of supporting the weight of the panel.
CAD02 only - Ensure that a 120V receptacle is within reach of the plug-in transformer.

The CAD series panel should be mounted directly below the boiler.

Step 1 Align and level the panel inlet/outlet piping with the boiler outlet/inlet piping.

Step 2 Secure the panel in place with supplied screws.

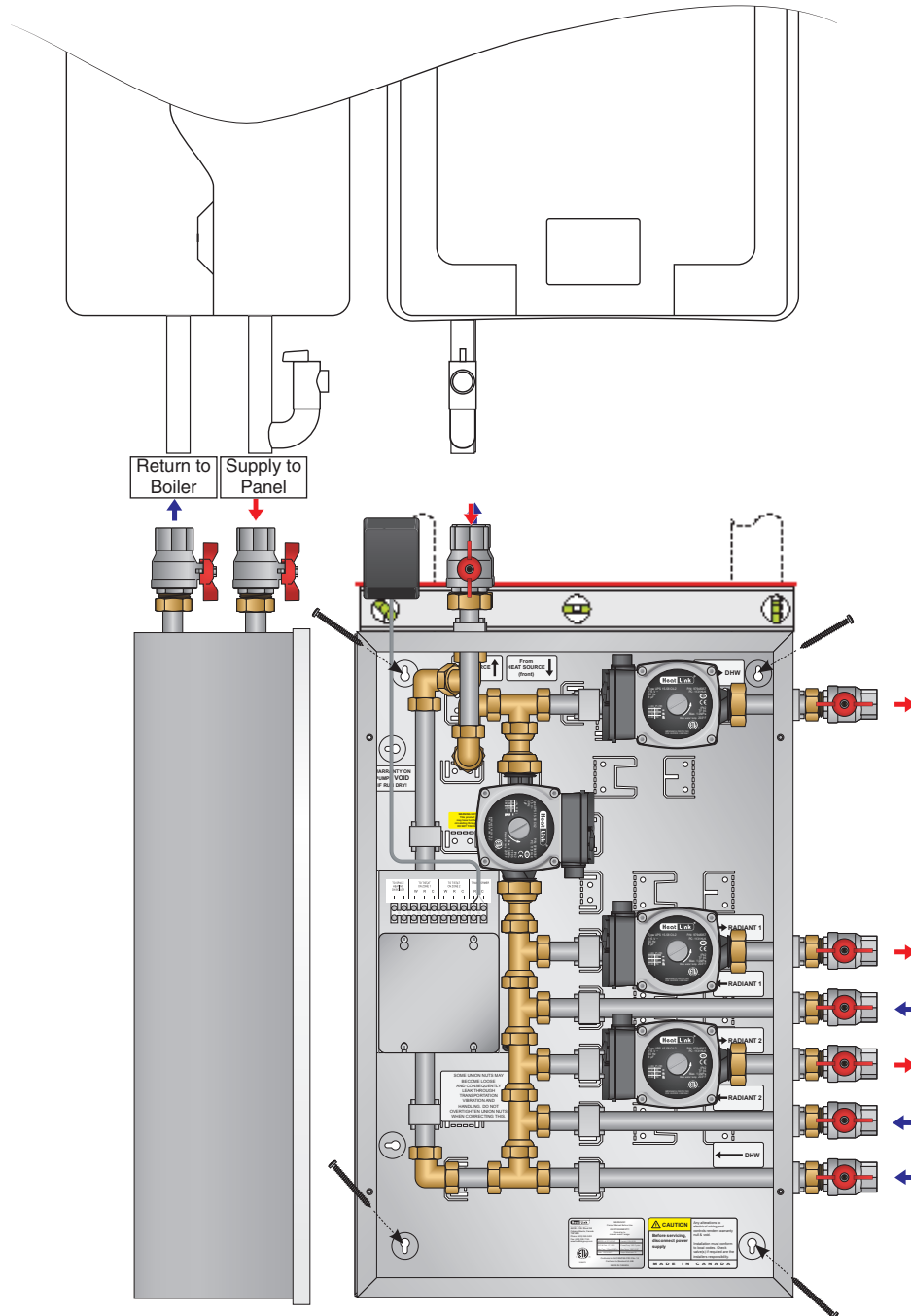

Piping Hookup

With the panel hooked up to the boiler (see page 8) you can now make the rest of the connections. The supplied washers (B) must be used for all panel connections - do not overtighten the panel connections, as this will damage the rubber washers.

You will need 2 x 30mm, or large adjustable (Crescent®) or smooth jaw pipe wrenches to tighten fittings.

Step 1 Connect the ball valves (C) to copper pipe or PEX tubing using a MNPT fitting or adapter (D), and then to the panel pipework.

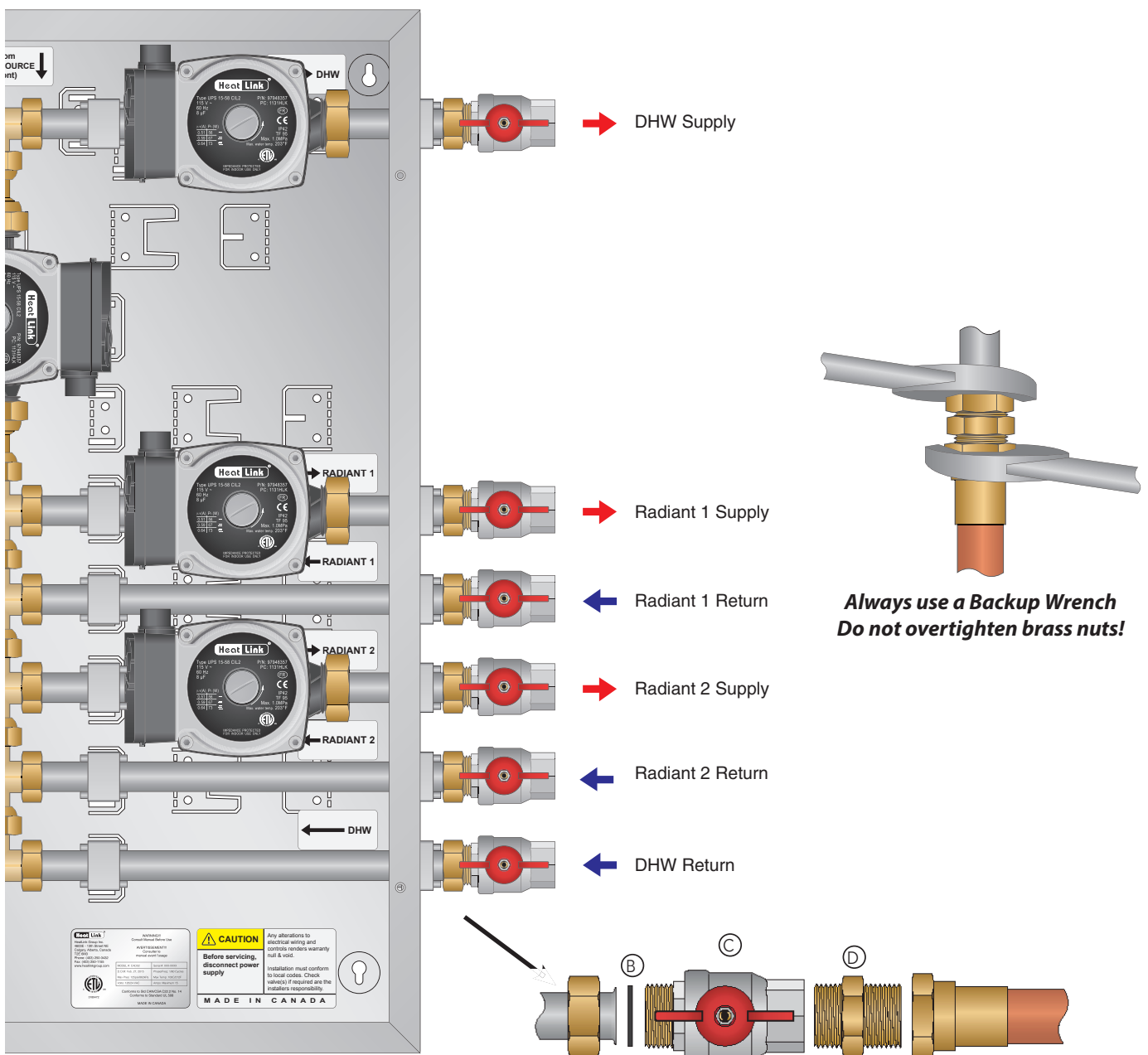

Note: Use precautions when soldering or applying heat within 16" of the panel.

Fill And Purge

The following steps are recommended in order to fill the panel with water and purge entrained air once piping is completed, and before activation of the panel.

Note: Additional purging steps may be required for the rest of the hydronic system.

- Step 1** Ensure the panel is not plugged in.
- Step 2** Fully close valves (A), (B), (C), (D), (E), and (F).
- Step 3** Attach a fill hose and a purge hose (not included) at the Heating Manifold supplied from valves (B) and (C).
- Step 4** Fill the system.
- Step 5** When the water coming out of the purge hose is free of bubbles fully open valves (B) and (C).
- Step 6** When exiting water from manifold is free of bubbles, close valve (B) and (C).
- Step 7** Repeat for valves (D) & (E).
- Step 8** Repeat for valves (A) & (F), and purge from drain point and indirect tank.
- Step 9** Remove hoses from manifolds and fully open valves (A), (B), (C), (D), (E), and (F).
- Step 10** Vent all pumps (use a large flat head screwdriver to avoid damage to vents) before starting the system.
- Step 11** Check for leaks at connections. If any leaks are found, use a back-up wrench and carefully tighten until leak stops. Do not overtighten.
- Step 12** Pressurize system to the required operating pressure.

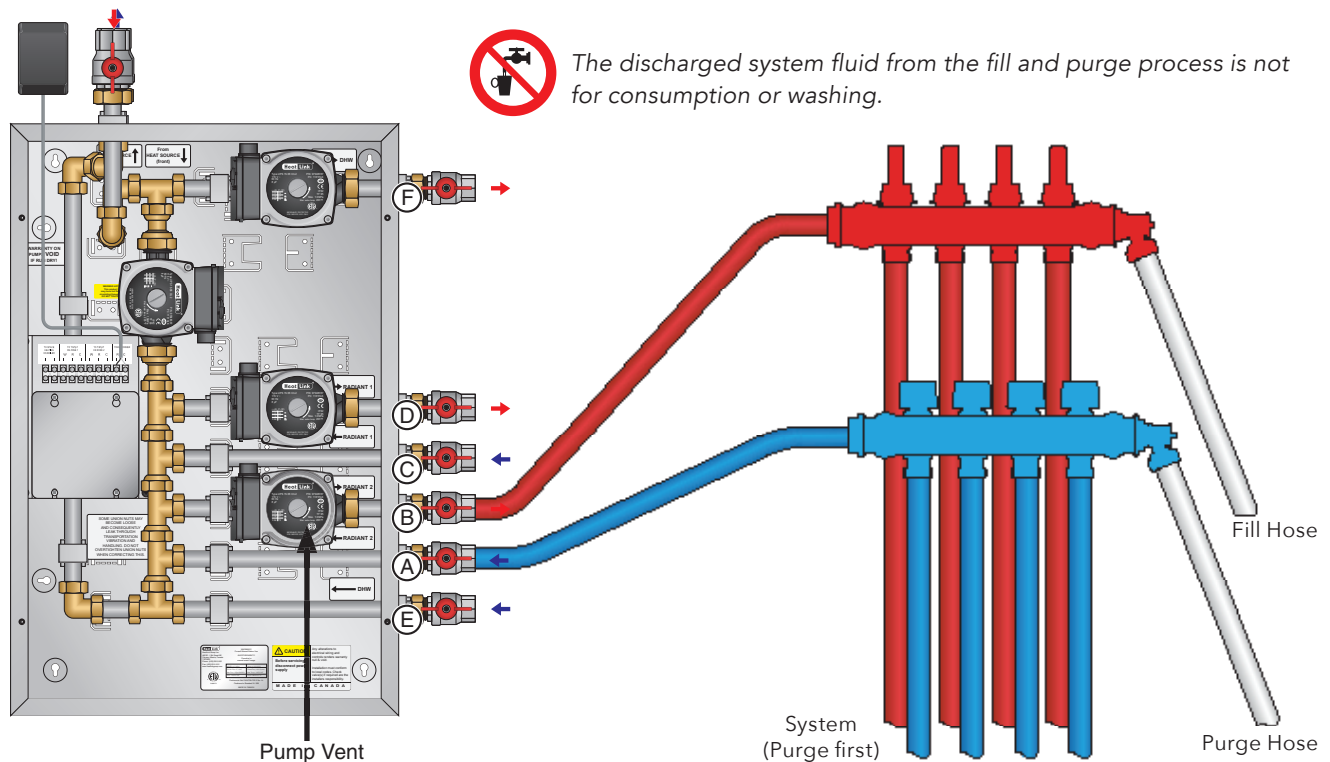

Panel Wiring

Thermostat Wiring (CAD02 only)



24V low voltage power may be supplied to the thermostat. Wiring of thermostat should be done by qualified electrician and should meet local codes and jurisdictions. Wiring to the terminal strip requires 18 gauge wire.



- Do not exceed 2VA per thermostat.
- Do not cross terminals C and R

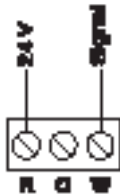

2-Wire Thermostat or StatLink[®]
(battery only or non-electric)

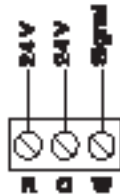

3-Wire Thermostat
(HeatLink thermostats)

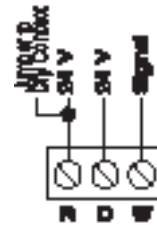

4-Wire Thermostat
(with dry contact signal)

CAD01 Panel Control Sequence & Wiring

Sequence of Operations – Space Heating

With 110V connections made to the boiler, a heat demand from the room thermostat ② will send a heating demand to the boiler. The boiler will turn on the Primary ③ circulator and Radiant ④ circulator. The supply water temp is determined by the boiler. When the heat demand is removed, the Radiant ④ and Primary ③ circulators will stop.

Sequence of Operations – DHW

With a demand from the DHW aquastat to the boiler, the boiler will turn on the DHW circulator ⑥, and turn off the Primary circulator ③, and the Radiant circulator ④ (if running) and change the supply water temp according to its settings. When the DHW demand is removed, the DHW circulator ⑥ will continue to run for as long as the boiler control requires.



All wiring should be done by a qualified electrician and should meet local codes and jurisdictions.

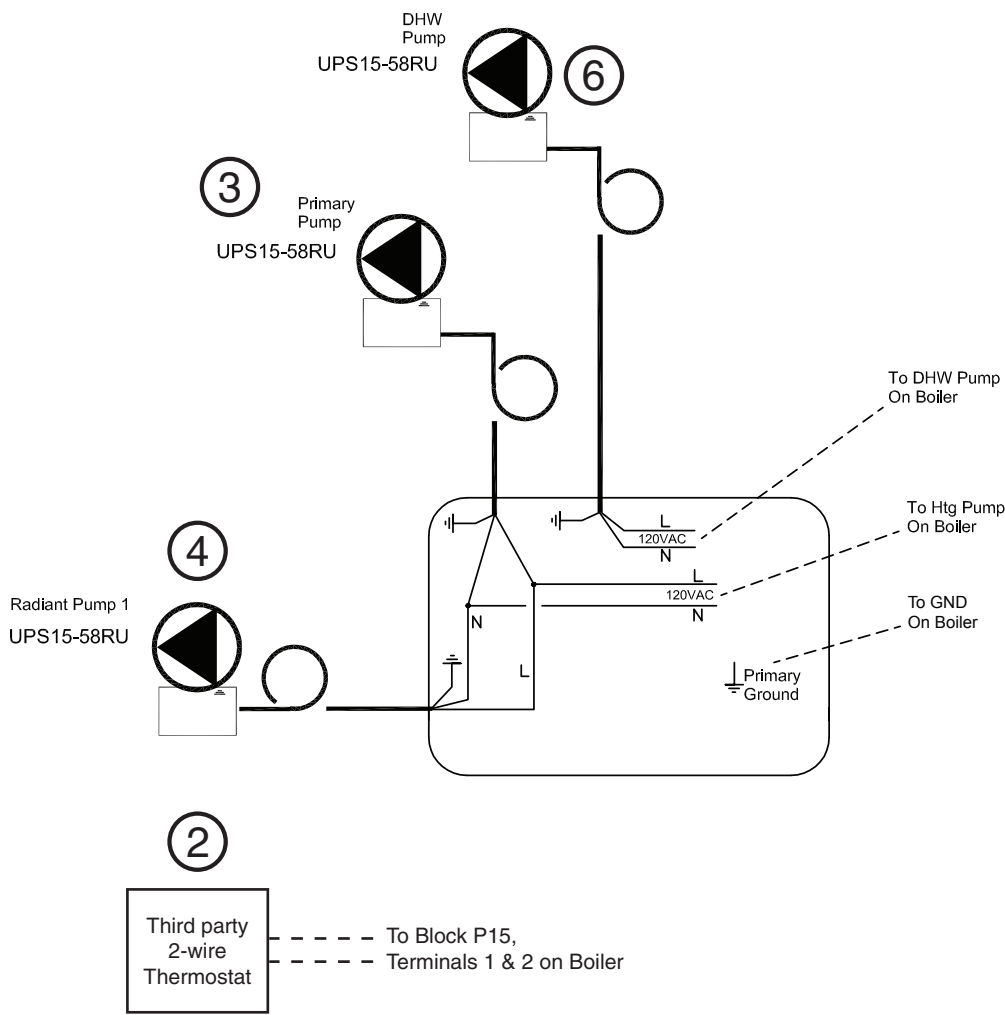

Note: HeatLink® 3-wire thermostats require the use of a relay, StatLink® 6 Zone Base Module, or Actuator with End Switch.

CAD02 Panel Control Sequence & Wiring

Sequence of Operations – Space Heating

With 110V connections made to the boiler and the transformer ① plugged in, a heat demand from either room thermostat ② will close its corresponding relay in the panel and send a heating demand to the boiler. The boiler will turn on the Primary ③ circulator and appropriate Radiant ④⑤ circulator. The supply water temp is determined by the boiler. When the heat demand is removed, the Radiant circulators ④⑤ will stop and the Primary ③ circulator will continue to run for as long as the boiler control requires.

Sequence of Operations – DHW

With a demand from the DHW aquastat to the boiler, the boiler will turn on the DHW circulator ⑥, and turn off the Primary Circulator ③, and the Radiant circulators ④⑤ (if running) and change the supply water temp according to its settings. When the DHW demand is removed, the DHW circulator ⑥ will continue to run for as long as the boiler control requires.



24V low voltage power may be supplied to the thermostat. Wiring to the terminal strip requires 18 gauge 4 wire. All wiring should be done by a qualified electrician and should meet local codes and jurisdictions.

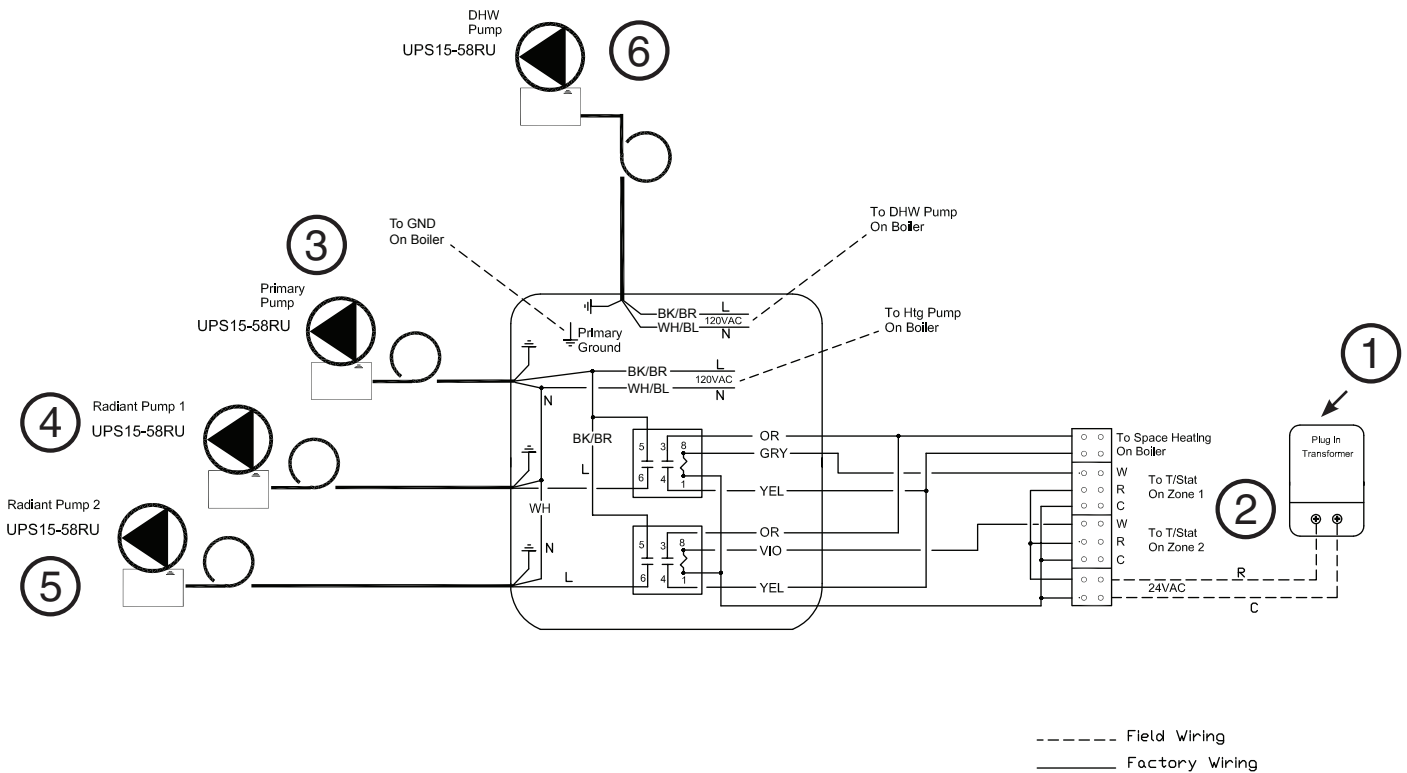

Troubleshooting

Problem	Check / Verify	Possible Cause
Low Temperature Within Room	Misplacement of thermostat location within room.	Make sure thermostat is not being influenced by an additional heat source, such as lighting or air duct.
	Low temperature setting of the thermostat.	Adjust the temperature setting on thermostat.
	The system fails to turn on if the thermostat is set to high setting	Thermostat may be out of calibration or defective. Replace thermostat.
	The electronic actuator fails to open during a call for heat	The electronic actuator may be improperly seated or may be defective. Replace if necessary.
	Wiring from heat source to panel.	Check that the wiring is done properly. Consult qualified electrician prior to alteration of wiring between heat source and panel.
	Output of heat source is unable to meet demand of heating system.	Compare output of heat source to the requirements of the heating system.
	Circulator is not on during a call for heat. (Use a stethoscope or similar device to verify)	The circulator may be defective.
	When zone valves are installed outside the panel a qualified electrician should verify 24V power is supplied to the thermostats and actuator.	The 24V transformer may have failed. Any zone valves must be opened manually to avoid dead-heading of the circulator.
High Temperature Within Room	Check current setting of the thermostat.	Adjust the temperature setting on thermostat to a lower setting.
	Installed electronic actuators remain open after the thermostat is satisfied.	An obstruction inside the zone valve is not allowing the actuator to fully close or the thermostat is still calling for heat.

Maintenance

Yearly maintenance should be done on the panel prior to each heating season to ensure the efficient and accurate operation of the panel.

Complete the following check list:

- Raise all thermostats to cause a call for heat within the system. Verify that the circulator starts, via a stethoscope or similar device.
- Confirm that the Auxiliary Contacts close.
- If applicable, verify that each zone valve opens during the call for heat – the actuator should be warm to the touch, the LED will light up (on 5620x models) and the white indicator should rise from the top of the actuator.
- Return all thermostats to a desirable setting.

You are now ready for another heating season with HeatLink.

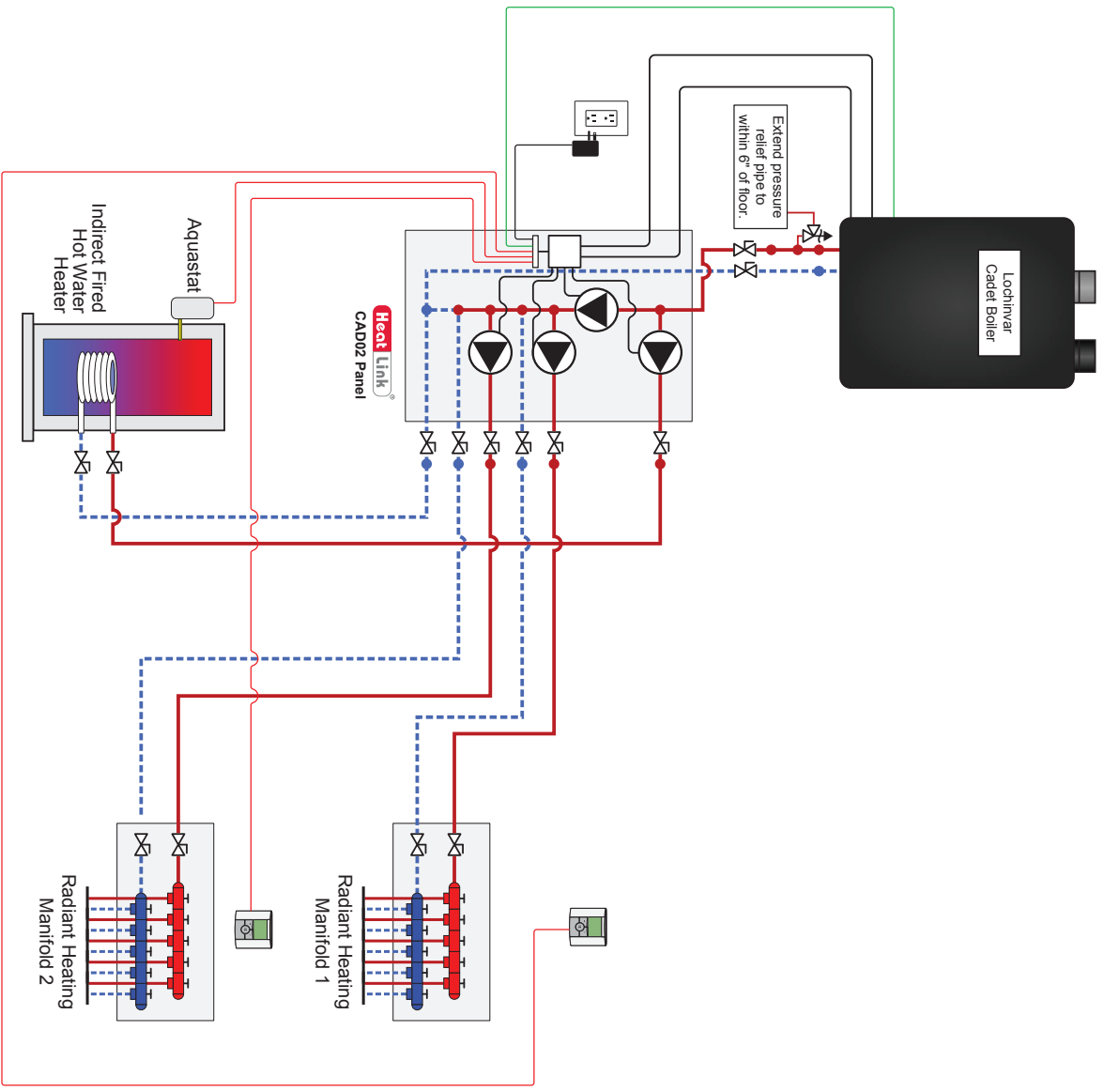

www.heatlink.com
1-866-661-5332

- Notes:**
- Drawings are for HeatLink suggested system layout only! User must determine if system layout will work for their particular application.
 - Air vents, expansion tanks, pressure relief valves, etc. for heat source as per local codes.
 - Use isolation ball valves for all circuits and components.
 - Local codes, regulations, and authorities have final jurisdiction.

Heat Source: Lochinvar Cadet Boiler
 Panel(s): CAD02
 Heat Load(s): IFHWH, Radiant Heating
 Date: 2016-05-11

Schematic #: SCG-CAD-M005
 Rough-in wiring see: SCH-MRIB-R001
 Wiring detail see: SCH-CAD-E002

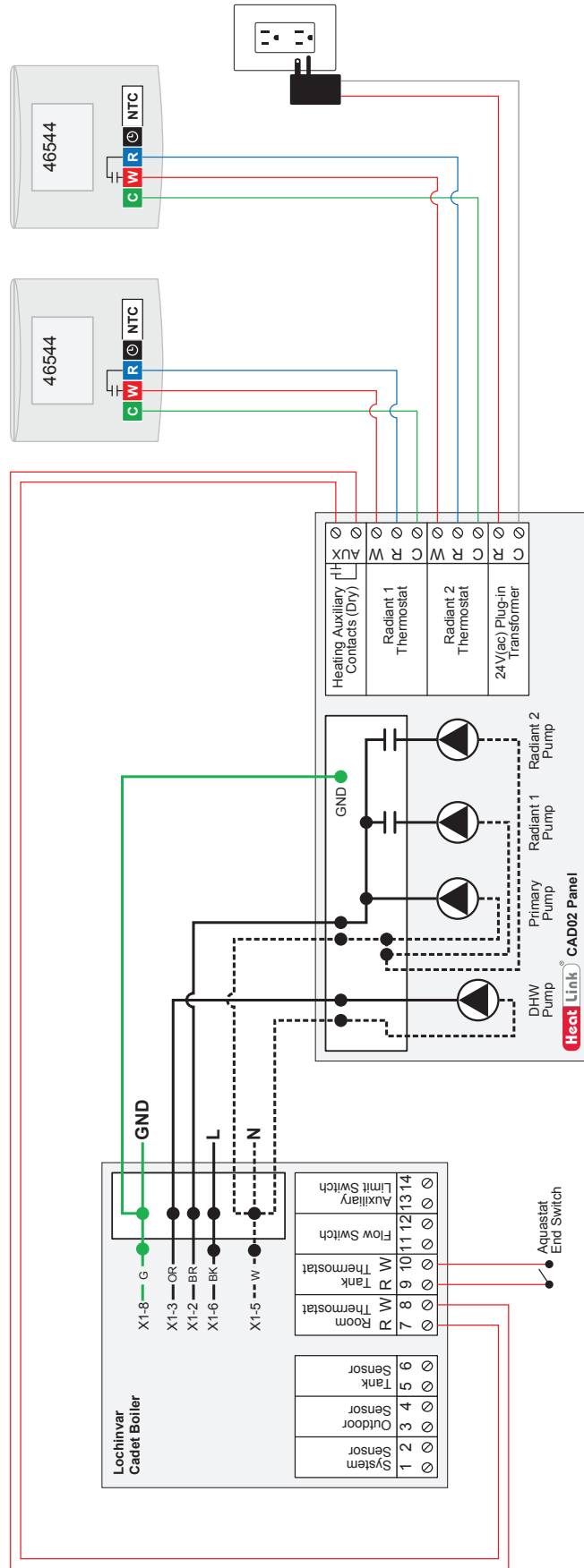

- Notes:**
- Drawings are for HeatLink suggested electrical schematics only. User must determine if electrical schematic will work for their particular application. User must also confirm all HeatLink schematics with manufacturer schematics of each particular control chosen.
 - In all cases manufacturer equipment schematics will take precedence over HeatLink electrical schematics.
 - Local codes, regulations, and authorities have final jurisdiction.

Heat Link
 www.heatlink.com
 1-866-661-5332

Application: Radiant Heating and Indirect Fired Hot Water Heater

Schematic #: SCH-CAD-E002

Rough-in wiring see:

Date: 2014-08-21

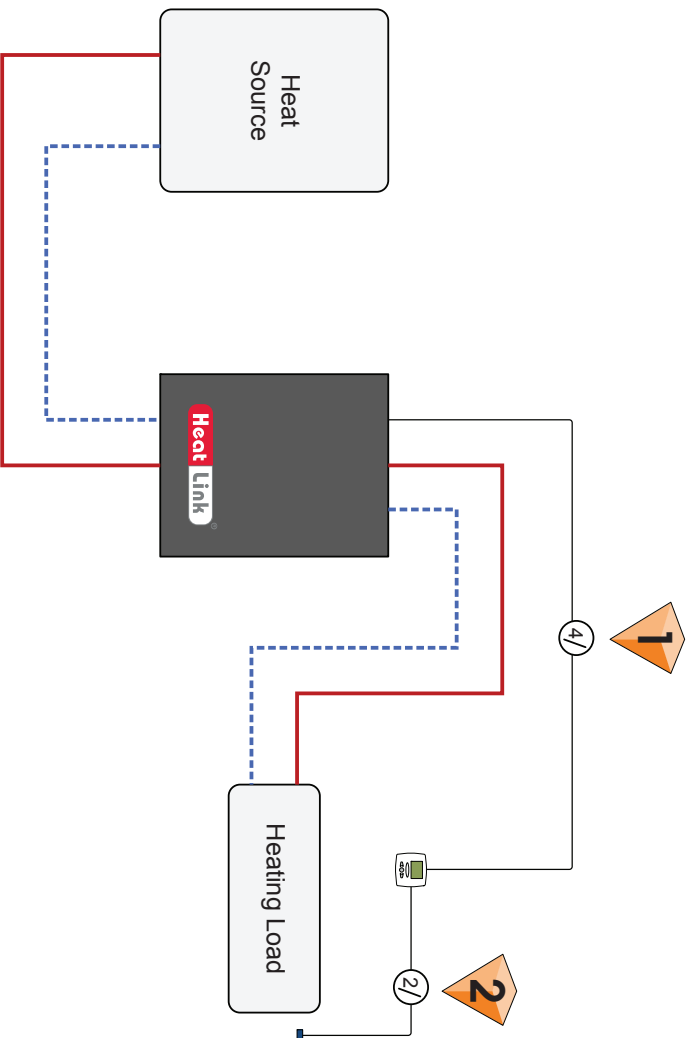

Room Thermostat
Standard 4-wire to be run from thermostat to mechanical room.



Floor Sensor (optional)
Standard 2-wire to be run from thermostat to floor sensor.

Notes:

- Drawings are for HeatLink suggested electrical schematics only! User must determine if electrical schematic will work for their particular application. User must also confirm all HeatLink schematics with manufacturer schematics of each particular control chosen.
- In all cases manufacturer equipment schematics will take precedence over HeatLink electrical schematics.
- Local codes, regulations, and authorities have final jurisdiction.



www.heatlinkgroup.com

1-866-661-5332

Application: Rough-in Wiring for One Zone Heating

Date: 2012-10-19

Schematic #: SCH-MRIB-R001

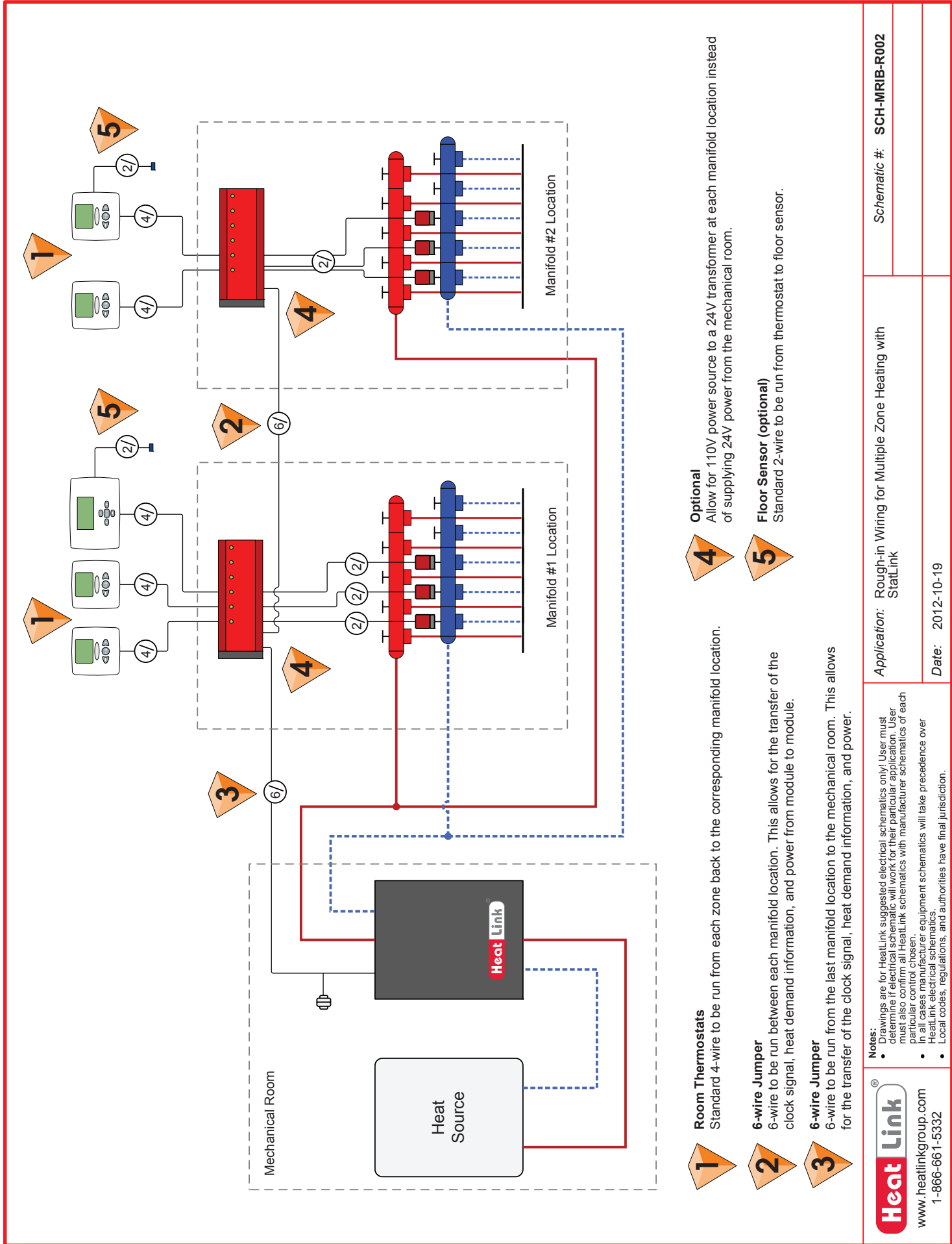

1 Room Thermostats
Standard 4-wire to be run from each zone back to the corresponding manifold location.

2 6-wire Jumper
6-wire to be run between each manifold location. This allows for the transfer of the clock signal, heat demand information, and power from module to module.

3 6-wire Jumper
6-wire to be run from the last manifold location to the mechanical room. This allows for the transfer of the clock signal, heat demand information, and power.

4 Optional
Allow for 110V power source to a 24V transformer at each manifold location instead of supplying 24V power from the mechanical room.

5 Floor Sensor (optional)
Standard 2-wire to be run from thermostat to floor sensor.

Heat Link
www.heatlinkgroup.com
1-866-661-5332

Notes:

- Drawings are for HeatLink suggested electrical schematics only! User must determine if electrical schematic will work for their particular application. User must also confirm all HeatLink schematics with manufacturer schematics of each particular control chosen.
- In all cases manufacturer equipment schematics will take precedence over HeatLink electrical schematics.
- Local codes, regulations, and authorities have final jurisdiction.

Application: Rough-in Wiring for Multiple Zone Heating with StatLink

Date: 2012-10-19

Schematic #: SCH-MRIB-R002

info@heatlink.com
www.heatlink.com

HeatLink, the HeatLink logo, and "Mechanical Room in a Box" logo are either registered trademarks or trademarks of HeatLink Group Inc.