

General Guidelines

Please review the instructions and warranty carefully. Assembly and installation are the installer's responsibility and beyond HeatLink's control.

1. Assemble the manifold under clean conditions. Any dirt on the o-rings may compromise the seal. **Ensure the o-rings are clean.**
2. Brace or support the supply and return mains parallel to the manifold and centered with the manifold's inlet and outlet. This will prevent stress and possible damage on the manifold supply and return end connections.
3. Use precautions when soldering or applying heat within 16" of any manifold component.
4. Ball valves in front of manifold are for isolating the manifold in case of servicing requirements.
5. Prevent aggressive substances from coming into contact with the manifold and its accessories. This warning includes, but is not limited to, bug sprays, lubricants, strong cleaning solvents, paints, bleaches, fluxes, etc. However, pipe dopes and Teflon tape are permitted for use on FNPT supply end connections. No tape or dope is needed where a gasket or o-ring seal is provided.
6. Protect the manifold during all phases of construction using a polyethylene sheet or a permanent HeatLink manifold enclosure.
7. The ports on the manifold are straight threads. Tightening an NPT threaded fitting into these ports can damage the manifold. For pressure testing use Pressure Test Kit #79935 or #79965. Only HeatLink Manifold accessories should be used on the manifold ports.
8. When installing actuators on the return manifold, the shut off cap must be removed.
9. Balancing valves will function sideways. **Manifolds are not to be installed upside down.**
10. Do not use HeatLink Stainless Steel Manifolds and accessories for purposes other than those for which they were designed. Do not exceed their specifications. Failure to follow these guidelines or the product's instructions will void the warranty.
11. In case a leak develops during testing, remove pressure from system before servicing the effected component.
12. **A water analysis is recommended for every installation site. For warranty claims a water analysis is mandatory.**
13. Consult with your HeatLink® dealer or distributor if you have any questions regarding the operations and limits of HeatLink products. Review all instructions and warranty information carefully.
14. Allow for a minimum of 6" (150 mm) clearance from top of manifold to frame opening for StatLink® Module rough in.
15. Allow a minimum of 24" (600 mm) above finished floor.

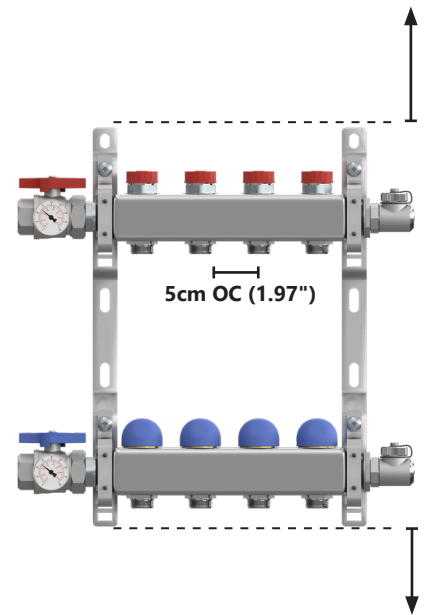
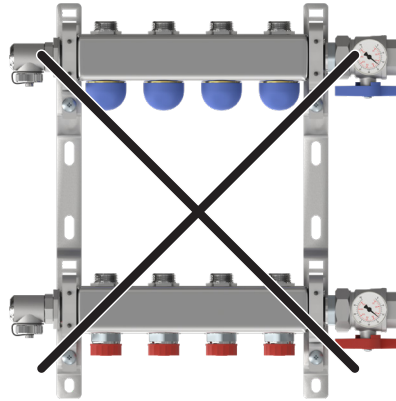

WARNING!

DO NOT disassemble the HeatLink Stainless Steel manifold while the system is under pressure. Serious injury can result.

Use only silicone o-ring lubricant #79951 or #79952. Use of petroleum based lubricants will void the warranty.

PEX Tubing to Manifold Connections using #77100 Series Connectors (sold separately)

77105 1/2", and 77119 5/8" Connectors include a nut and split ring ferrule pre-assembly, and a brass insert with O-ring.

1. Inspect all components for debris, obstructions, and/or damage prior to installation.
2. Lubricate the inside of the manifold port with silicone o-ring lubricant (#79952).
3. Cut the PEX tubing at a 90° angle.
4. Place the Nut and Ferrule pre-assembly onto the PEX tubing.

Method A

5. Push the Brass Insert into the PEX tubing as far as it will go.
6. Push the PEX tubing with Brass Insert as far as it will go into the connector base. Ensure the o-ring is clean and take care not to pinch it.
7. Use a wrench to tighten the nut.

Method B

5. Push Brass Insert as far as it will go into the manifold. Ensure the o-ring is clean and take care not to pinch it.
6. Push PEX tubing onto the Brass Insert as far as it will go.
7. Use a wrench to tighten the nut.

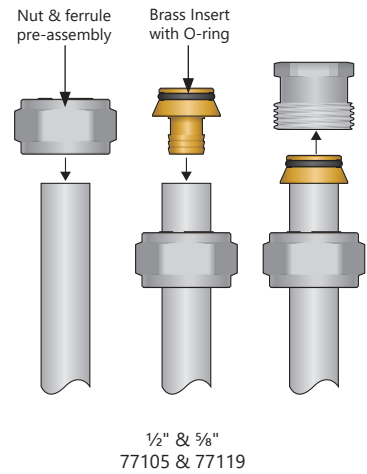

#77122 3/4" Connectors include a brass insert with O-ring, split ring ferrule, and nut.

1. Inspect all components for debris, obstructions, and/or damage prior to installation.
2. Lubricate the inside of the manifold port with silicone o-ring lubricant (#79952).
3. Cut the PEX tubing at a 90° angle.
4. Insert the split ring ferrule into the nut first. Open the split to ease insertion of the PEX.

Method A

5. Push the Brass Insert onto the PEX tubing as far as it will go.
6. Push the PEX tubing with Brass Insert as far as it will go into the connector base. Ensure the o-ring is clean and take care not to pinch it.

Method B

5. Push Brass Insert as far as it will go into the manifold. Ensure the o-ring is clean and take care not to pinch it.
6. Push PEX tubing onto the Brass Insert as far as it will go.
7. Use a wrench to tighten the nut.

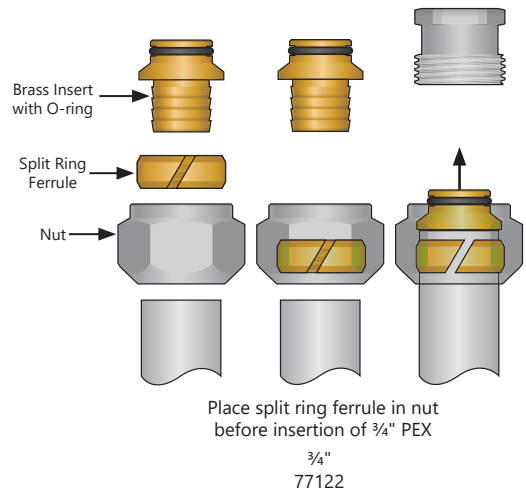

PEX Tubing to Manifold Conns using #EX77300 Series Expansion Connectors (sold separately)

#EX77300 Series Connectors (EX77305 1/2" and EX77319 5/8" and EX77322 3/4") include a nut and F1960 brass insert.

1. Inspect all components for debris, obstructions, and/or damage prior to installation.
2. Lubricate the inside of the manifold port with silicone o-ring lubricant (#79952).
3. Cut the PEX tubing at a 90° angle.
4. Push the brass insert to the manifold connector.
5. Use a wrench to tighten the nut.
6. Expand tubing and PEX ring, and place on brass insert.

For additional expansion fitting installation info see L3240 PEX-A Potable Expansion System Installation Guide

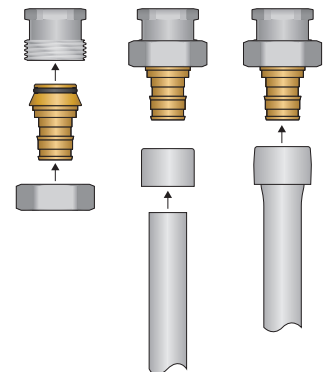

Balancing

HeatLink Stainless Steel Manifolds (75000 series) are balanced on the supply side only.

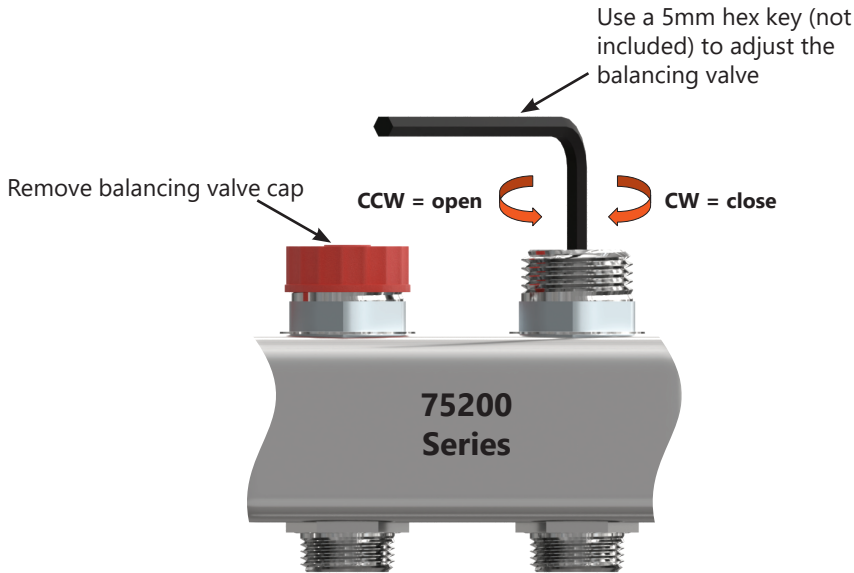

Balancing Valve Opening Turns	CV	KV
1	0.33	0.29
1.5	0.65	0.56
2	0.85	0.73
3	1.39	1.20
4	1.79	1.55
5	2.46	2.13
5.5 - Fully Open	2.73	2.36

Return Zone Valves Fully Open

Balancing Notes:

Supply : Use for primary balancing / fine tuning the flow rate. Remove balancing valve cap and use a 5mm hex key (not included) to adjust.
Return: No balancing available. Cap is used for shut off only.

Balancing Method:

1. Ensure all supply valves are open [factory open].
2. Ensure all return valves are open (remove blue cap).
3. Adjust the balancing valves to desired setting using the above chart.
4. Loops adjusted first may need to be re-adjusted once all other loops have been set.

Notes

- Hose bib thread is 3/4" GH thread. ②
- After fill procedure: the drip cap ① should be placed back on to the hose bib ②

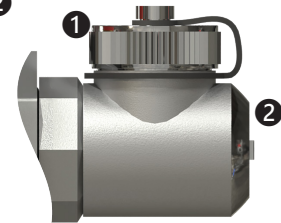

75200 Series Friction Head Graph

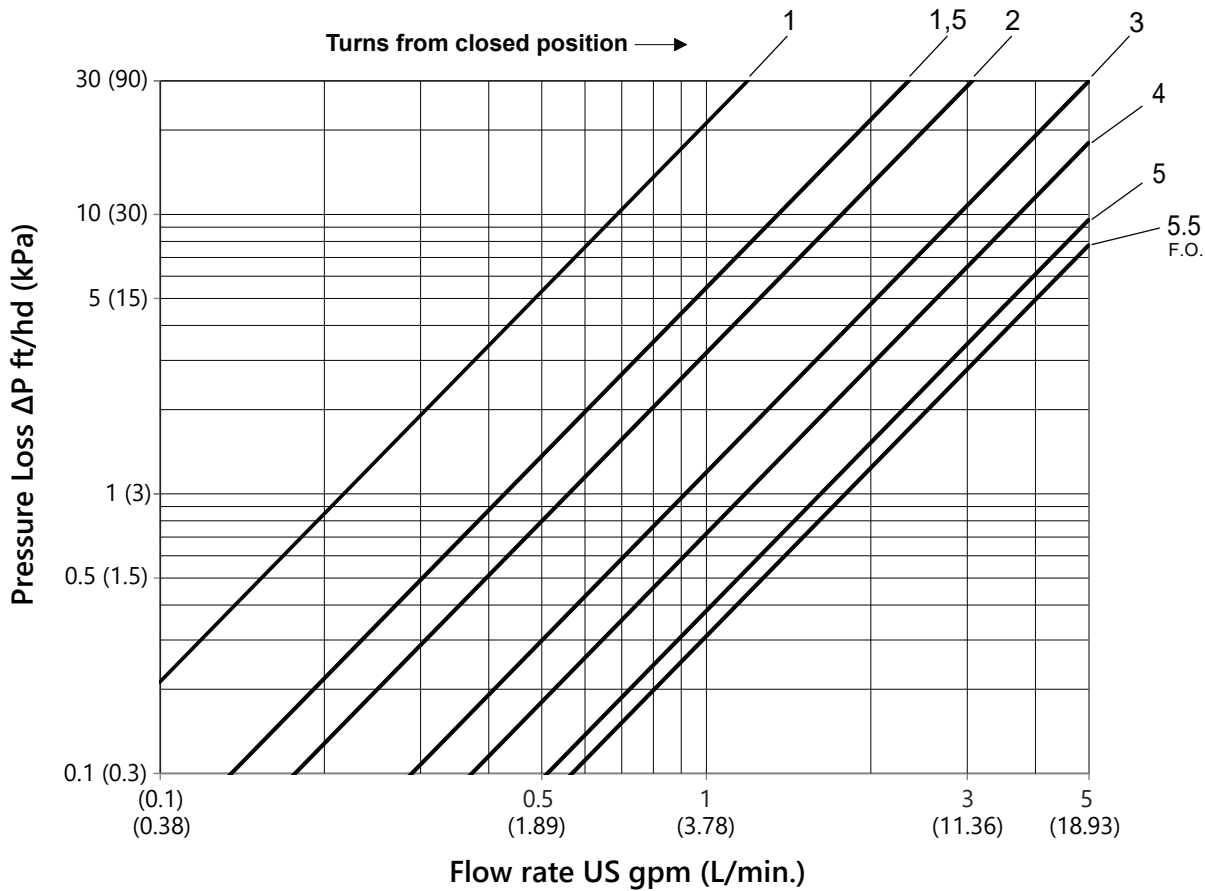

75200 Series Technical Data

Operating pressure	145 psi (10 bar)
Maximum continuous working temperature	185 °F (85°C)
Maximum Test Pressure	232 psi (16 bar)
Maximum differential pressure.....	14.5 psi (1 bar)
Heat Transfer Fluid.....	Water / Mixture of water with anti-freeze liquids
Maximum glycol percentage.....	50%
Thermometer scale.....	32 to 175 °F (0 to 80 °C)
Supply Balancing Valve (wide open).....	Cv 5.1 (Kv 4.41)
Return Zone Valve (wide open)	Cv 3.24 (Kv 2.80)
Global Flow Coefficient of the manifold	Cv 2.73 (Kv 2.36)(Supply + Return together)
Manifold Union.....	G1" Female
Full Port ball valve connection.....	1" NPT Female x G1" Male
Loop connections	G3/4" Eurocone (EK20)
Fill and Drain valve connections	3/4"GHT
Actuator adapter connection	M30x1.5
Manifold body material.....	Stainless Steel ASTM EN10088 1.4306 (AISI304)
Brass components material.....	ASTM B124 C37700 (CW614N and CW617N)
Bracket material.....	Carbon steel white zinc plated

Maintenance

- The following maintenance should be performed on an annual basis.
1. Inspect the system for leaks and erosion of metal/plastic components.
 2. Retighten nuts as needed.
 3. Water analysis (i.e. check corrosion inhibitor and/or glycol levels).
- At 10-year intervals the Zone Valve Inserts in the return manifold and the O-rings in the supply manifold should be replaced.