

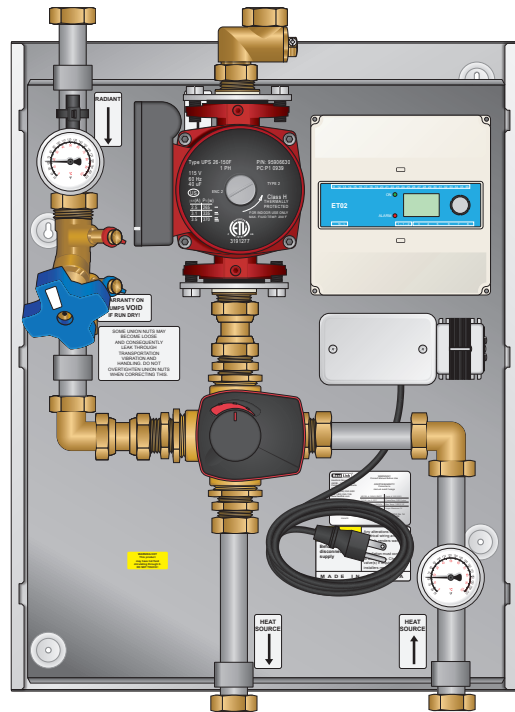

## 4WMIX-SMCP

### Installation, Operation, and Maintenance Manual

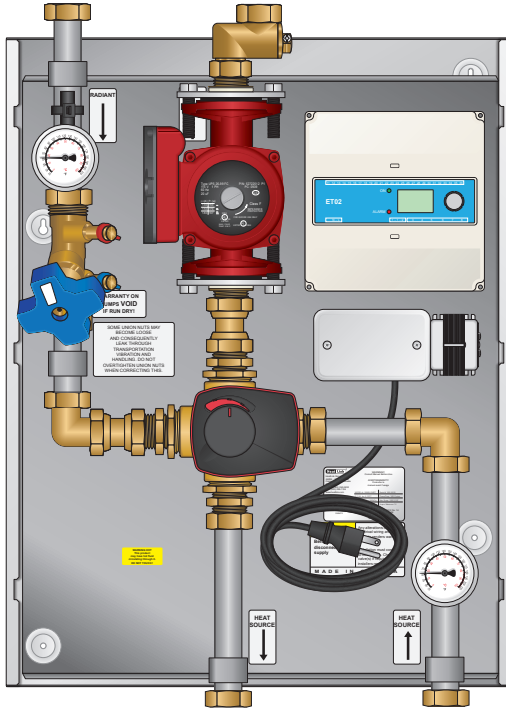

# Table of Contents

2	Warnings
2	Servicing
2	Tools
3	Function
3	Unpacking
4	Panel Components
5	Panel Components (cont'd)
5	Specifications & Listings
9	Panel Mounting
10	Piping Hookup
11	Fill & Purge
12	Piping Options
13	Panel Wiring
13	Wiring Diagram
14	Panel Control Sequence
15	System Controller
20	Troubleshooting
21	Testing the Sensor

## Disclaimer

HeatLink Group Inc. shall not be responsible for errors in its brochures or printed materials. HeatLink Group Inc. reserves the right to alter its products at any time without notice, provided that alterations to products already on order shall not require material changes in specifications previously agreed upon HeatLink Group Inc. and the Purchaser. All trademarks in this material are property of the respective companies. HeatLink and the HeatLink logotype are trademarks of HeatLink Group Inc. All rights reserved.

## Warnings

The zone control panel is for indoor use only and must be installed by a qualified installer/service technician. This product must be installed and operated in strict accordance with the terms set out in this manual and in accordance with the relevant requirements of the Local Authority Having Jurisdiction. Failure to comply will result in a void of warranty, and may also result in property damage, serious injury, or death.

## Servicing

Prior to commencing installation of this panel it is necessary to read and understand all sections of this manual. The symbols below are used throughout this document to ensure proper operation of the panel, and your safety. Please pay attention to these symbols.



**Warning**  
**Possible Hazard**



**Warning**  
**Live Power**



**Warning**  
**Hot Pipes**



**Warning**  
**Treated Water**



In order to avoid injury or death, switch off the power to the panel prior to inspecting or making connections to the terminal strip.

## Tools

- Level
- Screwdriver or power drill
- Flat head bit
- Phillips head bit # 2
- 2 adjustable wrenches (or 2 × 30mm wrenches)

## Function

This zone control panel can provide mixing, distribution, and zoning for a wide variety of hydronic heating applications.

The effectiveness of the system is dependant on the system being designed and installed correctly. Proper consideration of factors such as BTU loads, outdoor design temperature, indoor design temperature, room set-point temperature(s), differential fluid temperatures, head loss, flow rates, and transfer capacities of the heat emitters is critical.

Once these factors have been considered and the system requirements determined, these can then be evaluated and compared to the panel capabilities.

**Note:** This panel does not regulate or monitor the operating safety limit temperatures of the fluid leaving the heat source.

## Unpacking

- Step 1** Examine carton for any damage that may have occurred during shipping. If damage is visible notify your courier and supplier immediately.
- Step 2** Open the carton by removing the staples.
- Step 3** Remove the cardboard spacers from the carton, then remove the panel from the carton. Lift the panel by the base, not the enclosure.
- Step 4** There are 2 screws holding the enclosure in place during shipping. They are located at the top left & right of the panel base. Remove these 2 screws.
- Step 5** Remove the enclosure from the panel by sliding it upwards until it stops, then gently pulling outwards off.

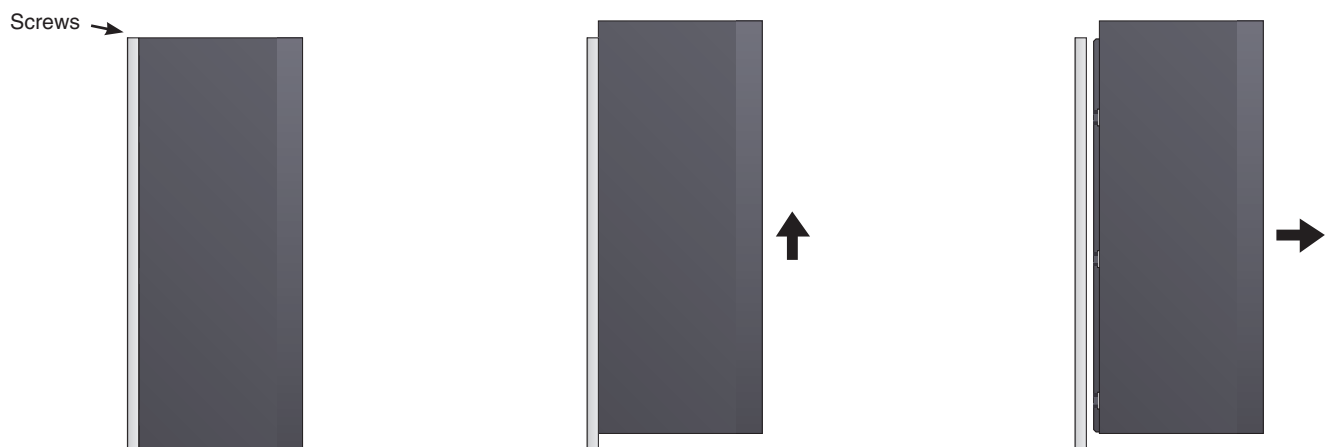

Panel Components

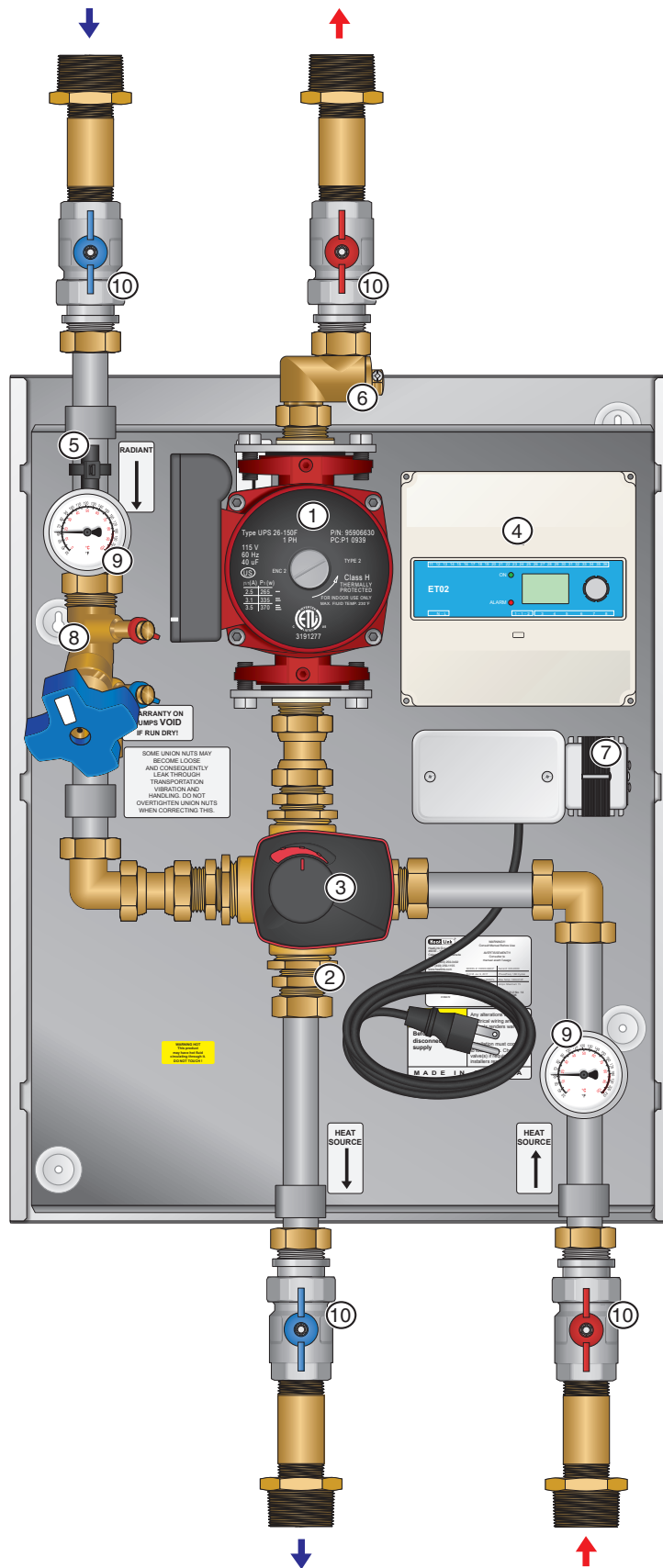

Panel Components (cont'd)

#	Components	Part Number	
		4WMIX-SMCP	4WMIXHH-SMCP
1	Secondary pump	UPS26-99	UPS26-150
2	1¼" Mixing valve (hidden)		64031
3	Mixing valve motor		58132
4	Snow Melt control		ETO2SMCNTR
5	Return sensor		ETF1899ASNS
6	Supply sensor		ETF1899ASNS
7	24V(ac) transformer		n/a
8	Balancing valve		n/a
9	Thermometer		n/a
10	Isolation valve assemblies*		n/a

\*Packaged in accessory box for shipping. See page 10 for piping hookup instructions.

Specifications & Listings

	4WMIX-SMCP	4WMIXHH-SMCP
Listing		cETLus
Conforms to		CAN/CSA-C22 No.14, UL508
Dimensions		24"H × 18¾"W × 8"D
Weight		
Max ambient temperature		120°F
Max water temperature		200°F
Settable fluid temperature range		100-145°F
Power supply	120V(ac)	
Circulator	Ferrous, Grundfos UPS26-99FC	Ferrous, Grundfos UPS26-150FC
Auxiliary terminal		none
Temperature control method		1¼" 4-way mixing valve and [floating point] motor
Temperature control range		
Mixing valve Cv		18.7
Piping		1" 304 stainless steel tubing, 1" brass
Piping connections		1½" MNPT
Backplate		Galvanized steel
Enclosure		Powder coated steel

### Panel Component Specifications

#### Circulator

The circulator moves the heated fluid through the system when there is a call for heat from the system controller.

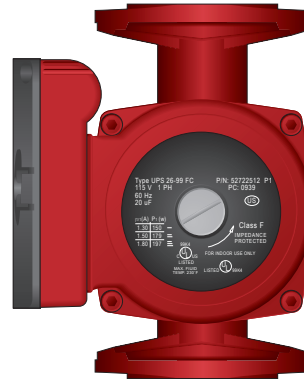

The addition of glycol to the system will result in higher demand from the circulator due to the change in viscosity of the fluid.

#### Technical Data - UPS 26-99 FC

Material:

- Inlet cone, bearing plate, bearing retainers, rotor can, rotor cladding, shaft retainer:..... Stainless Steel
- Stator Housing:..... Aluminium
- Shaft, upper and lower radial bearings:..... Aluminium oxide ceramic
- Thrust bearing: ..... Carbon bearing and EPDM retainer
- Check valve: ..... ACETAL with 302 SS spring and nitrile rubber seats
- Pump housing (volute):..... Cast iron
- O-ring and gaskets: ..... EPDM
- Impeller: ..... PES composite (30% glass-filled)
- Terminal box: ..... Noryl® with EPDM gasket
- Flow Range: ..... 0-33 US gpm (0-7.5 m<sup>3</sup>/h)
- Head Range:..... 0-29 ft (0-8.8 m)
- Motors:..... 2-pole, single-phase
- Max. Liquid Temperature: ..... 230°F (110°C)
- Min. Liquid Temperature: ..... 36°F (2°C)
- Max. System Pressure:..... 145 psi (10 bar)

Speed	Volts	Amps	Watts	Hp	Capacitor
3	115	1.8	197	1/6	20 µF/180V
2		1.5	179	1/6	
1		1.3	150	1/6	

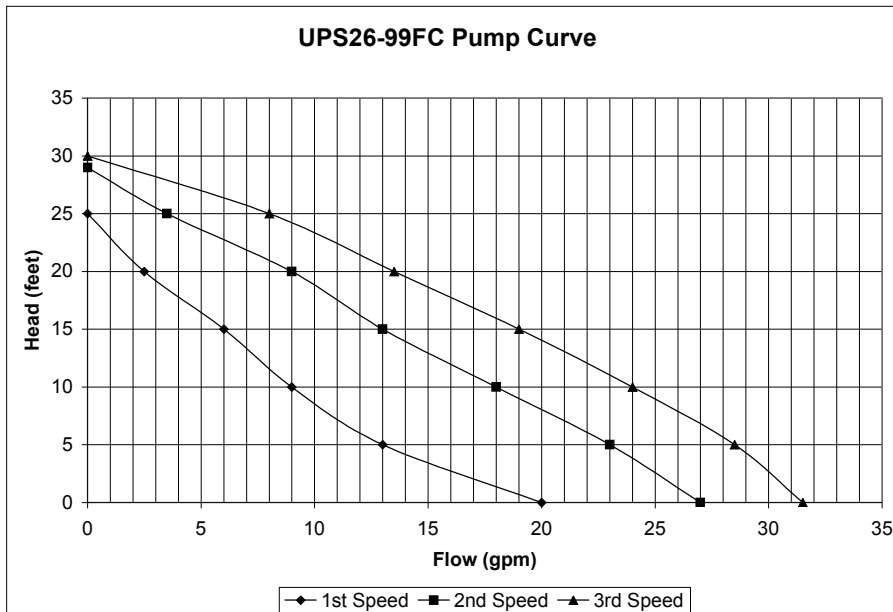

**Technical Data - UPS 26-150 FC**

Material:

- Inlet cone, bearing plate, bearing retainers, rotor can, rotor cladding, shaft retainer:..... Stainless Steel
- Stator Housing:..... Aluminium
- Shaft, upper and lower radial bearings:..... Aluminium oxide ceramic
- Thrust bearing: ..... Carbon bearing and EPDM retainer
- Check valve: ..... ACETAL with 302 SS spring and nitrile rubber seats
- Pump housing (volute):..... Cast iron
- O-ring and gaskets: ..... EPDM
- Impeller: ..... PES composite (30% glass-filled)
- Terminal box: ..... Noryl® with EPDM gasket
- Flow Range:..... 0-53 US gpm (0-12 m<sup>3</sup>/h)
- Head Range:..... 0-46 ft (0-14 m)
- Motors:..... 2-pole, single-phase
- Max. Liquid Temperature: ..... 230°F (110°C)
- Min. Liquid Temperature: ..... 36°F (2°C)
- Max. System Pressure:..... 145 psi (10 bar)

3	115	3.5	370	1/6	40 μF/180V
2		3.1	335	1/6	
1		2.5	265	1/6	

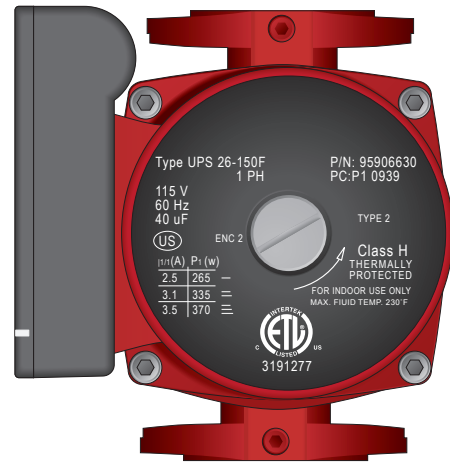

**UPS 26-150 Pump Curve**

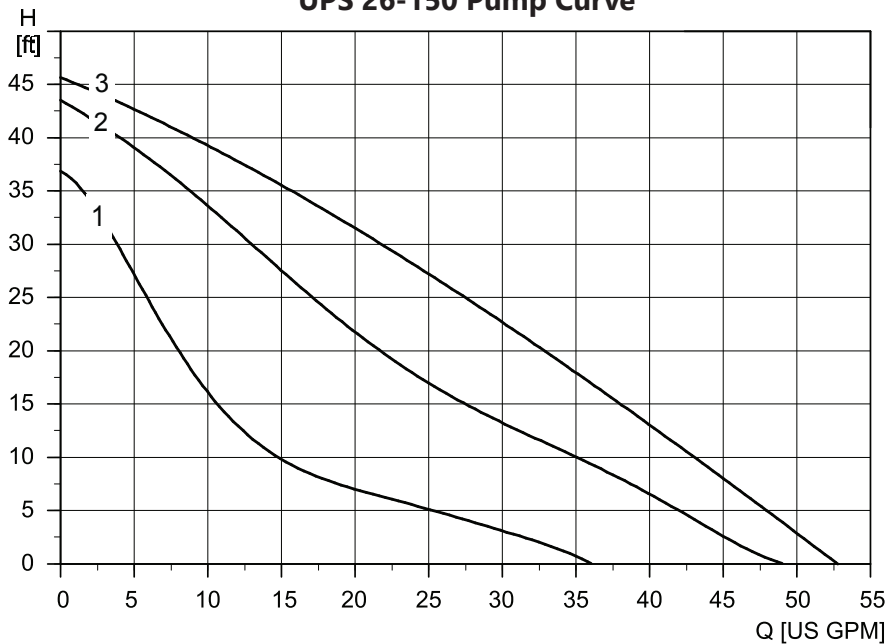



**Control Valve**

4-way brass mixing valve regulates the temperature in the hydronic system with the help of the electric motor actuator and system controller.

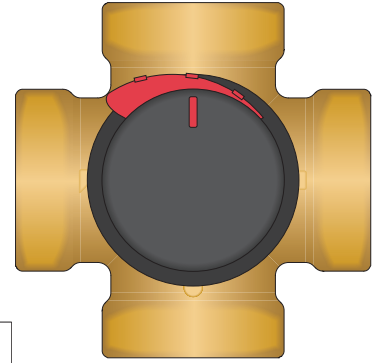

**Technical Data - 4-way mixing valve**

Material - Valve Body & Slide: .....	Brass DZR
Material - Shaft & Bushing:.....	PPS composite
Material - O-ring:.....	EPDM
Max. Operating Temperature:.....	230°F (110°C)
Min. Operating Temperature:.....	-15°F (-10°C)
Max. Operating Pressure:.....	145 psi (10 bar)
Max. Differential Pressure: .....	14.5 psi (1 bar)
Leaking in % of flow*: .....	<1.0%
Max. Torque:.....	<44lbf*in (<5Nm)

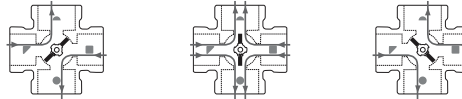
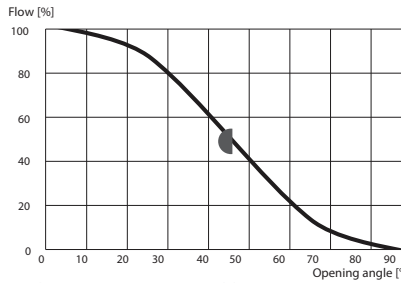

\*based on diff. pressure of 14.5 psi (1 bar)

**Mixing Valve Motor**

The mixing valve motor is mounted to the control valve and moves the valve appropriately to allow the heated fluid to enter. This motor works in conjunction with the system controller.



**Manual Operation of Mixing Valve Motor**

NOTE: Mixing Valve Motor should not be placed in manual mode for an extended period of time.

- Pull knob out on motorized actuator.
- Rotate knob clockwise or counter-clockwise.
- To return to automatic mode, push the knob in.

**Technical Data for 58132 DDC mixing valve motor**

Ambient Temperature: .....	23 to 131°F (-5 to 55°C)
Power Supply: .....	24Vac/dc ± 10%, 50/60 Hz
Enclosure Rating: .....	NEMA 1, IP41
Protection Class: .....	II
Torque:.....	53.1 lbf.in (6 Nm)
Power Consumption - Operation: .....	AC: 5W
	DC: 2.5W
Power Consumption - Dimensioning: .....	AC: 8 VA
	DC: 4 VA
Angle of Movement:.....	90°
Running Time 90°:.....	45/120 sec
Control Signal .....	0-10V, 2-10V, 0-20mA, 4-20mA
Cable Length: .....	4.9 ft (1.5 m)

The motor should be preceded by a multi-pole contact breaker in the fixed installation.

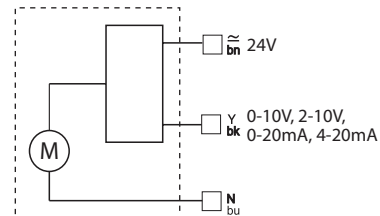

CE LVD 2006/95/EC  
EMC 2004/108/EC  
RoHS 2002/95/EC

## Panel Mounting

Prior to mounting the panel, ensure the wall is capable of supporting the weight of the panel, and that all required power outlets and/or wiring is available at the installation location.

- Step 1** Determine the location and distance between the wall studs. With a level at a minimum height of 4' from the floor, draw a straight line and mark the stud locations. If the panel cannot be secured directly to the studs, or suitable backing boards, plywood may need to be installed behind the panel to properly secure it in place.
- Step 2** Screw two of the supplied mounting screws into the wall studs (or backing plywood) 3/4" and 6 1/2" from the top of the desired height, and 16" apart, leaving 1/4" of the screw out from the wall.
- Step 3** Lift and place the panel onto the mounting screws. Two person lift may be required.
- Step 4** Screw the remaining mounting screws into the holes at the bottom of the panel, and tighten the top two screws.

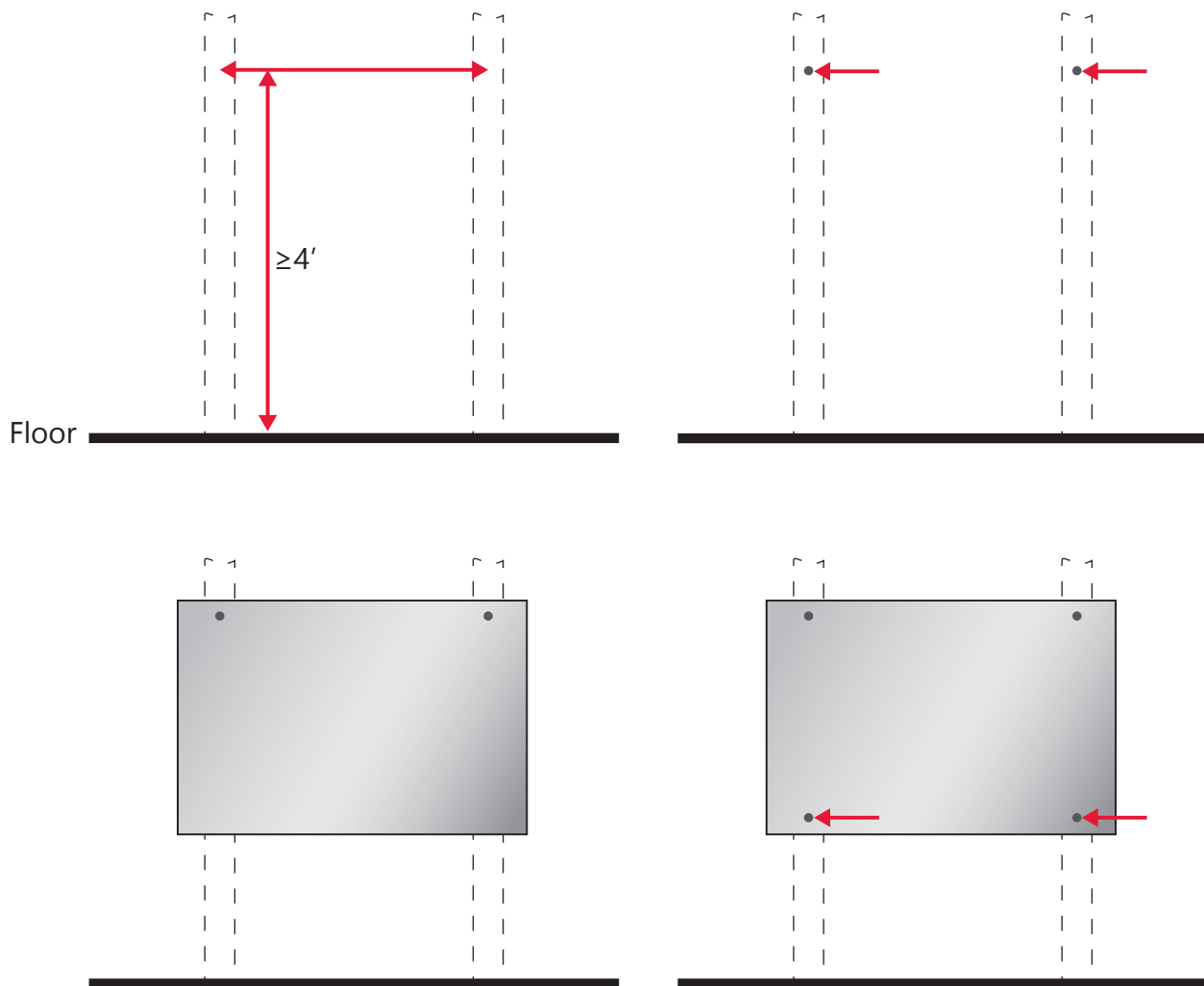

### Piping Hookup

The 4WMIX-SMCP ships with the adapter assemblies packaged in the accessory pack, and must be connected to the panel *after* the system connections have been made.

- Step 1** Piping connections are 1-1/2" MNPT. Use appropriate thread sealant and backup wrench when making connections.
- Step 2** Connect adapter assemblies to the panel. The supplied washers must be used, and nuts must not be overtightened as this may damage the washers.

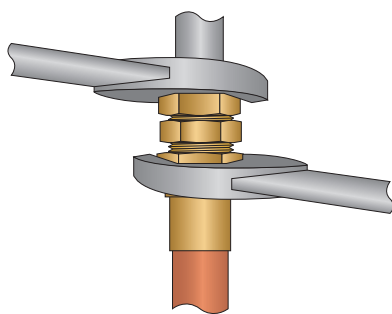

*Always use a Backup Wrench  
Do not overtighten brass nuts!*

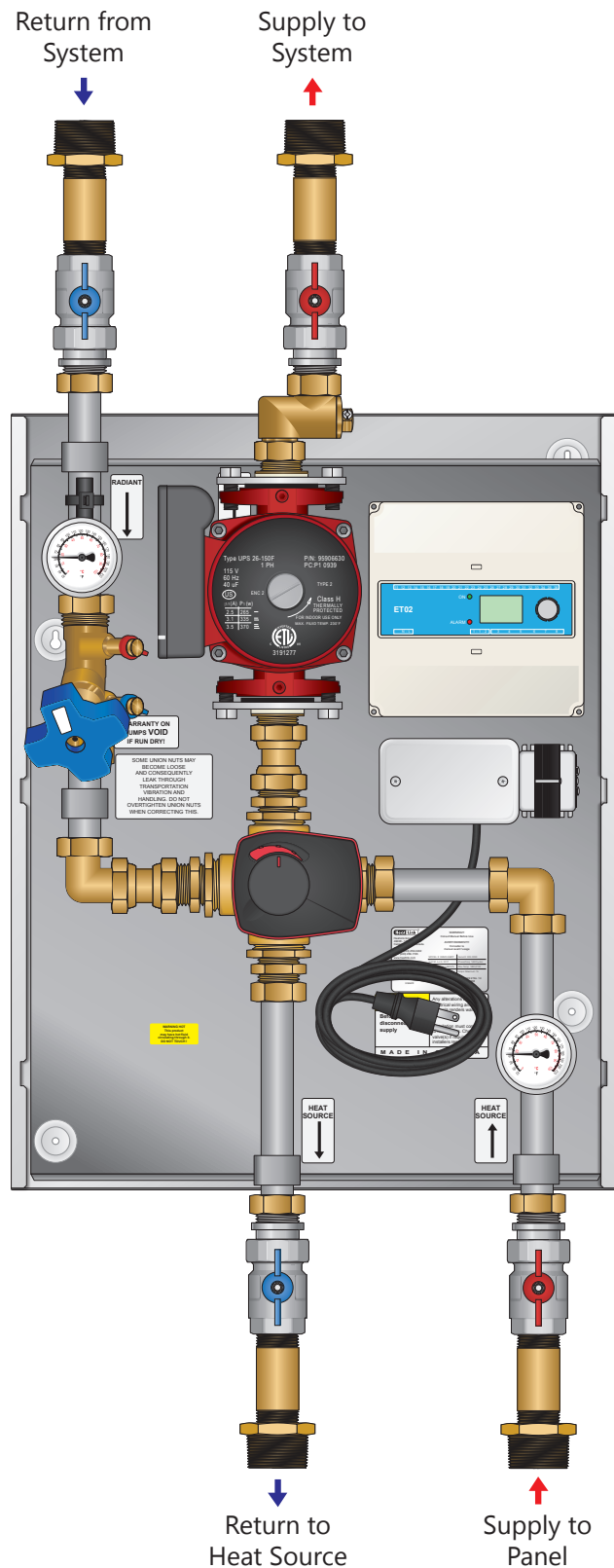

**Fill & Purge**

- Step 1 Ensure the panel is not plugged in.
- Step 2 Fully open the mixing valve (fig. B)
- Step 3 Close all isolation ball valves, and attach the fill and purge hoses (not included) to the system fill and purge valves. Open valves.
- Step 4 Open isolation valves and allow water to run until it is free of bubbles.
- Step 5 Close system fill and purge valves.
- Step 6 Detach fill and purge hoses.
- Step 7 Check for leaks at connections. If any leaks are found, use a back-up wrench and carefully tighten until the leak stops. **Do not overtighten!**

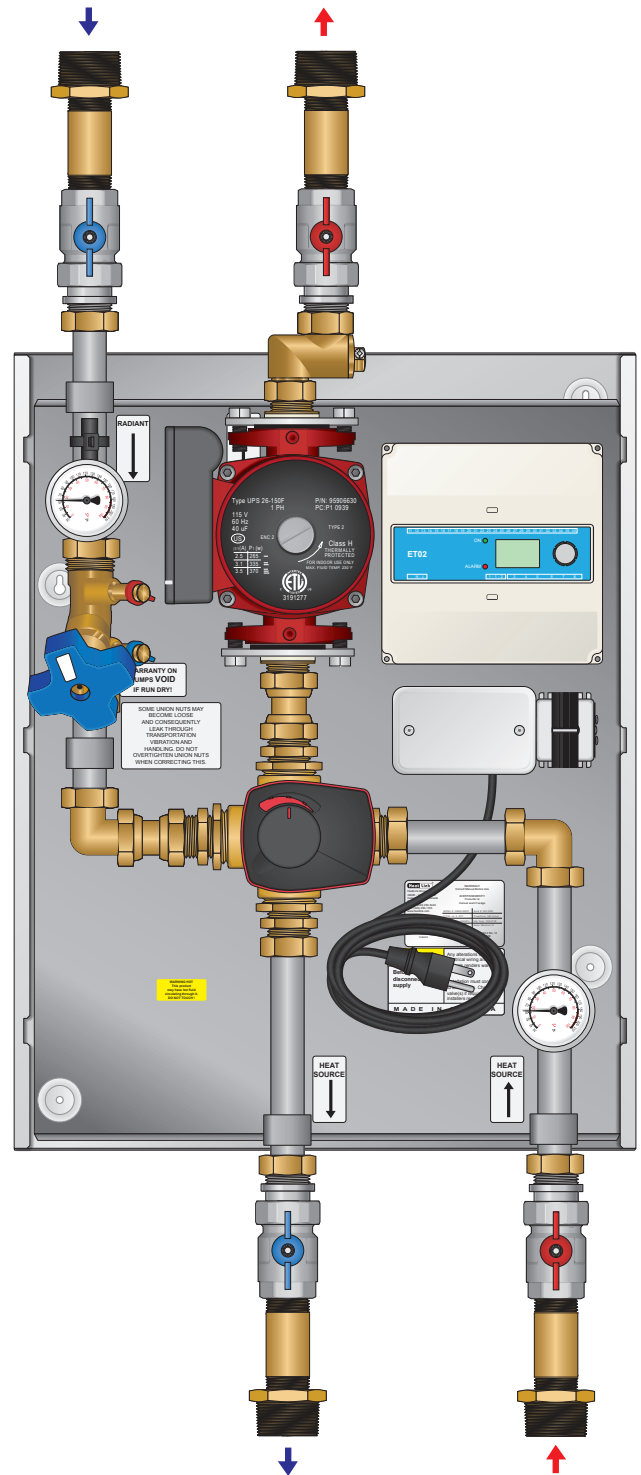

## Piping Options

### Option #1: Parallel Primary/Secondary

**Pros:**

- Supply water temperature the same for each load
- No possible pump interference

**Cons:**

- Requires additional balancing valves for each load take off.
- Hot water migration/gravity flow possible in return riser. Flow check, Spring loaded check valve or thermal trap required in return riser.
- Critical on site installation (Tee spacing and pipe sizing)
- Complex piping

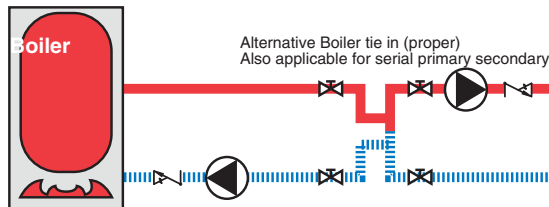
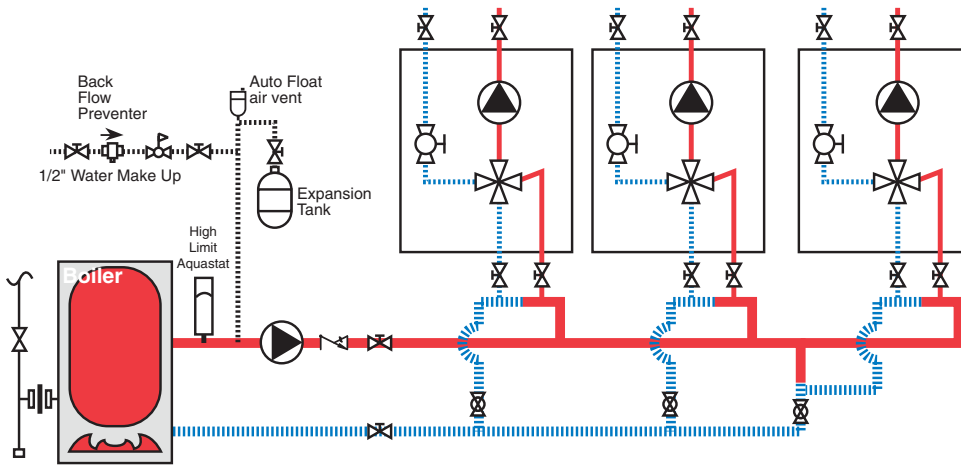

Proper Primary/Secondary piping (shown as alternative boiler tie in), requires an additional pump and triple (rather than the much more common double) pole relays (see page 22).

### Option #2: Series Primary/Secondary

**Pros:**

- Automatic priority
- No possible pump interference

**Cons:**

- Supply water temperature lowers for each load, this change of temperature is not constant. Some loads may not function if temperature is too low.
- Very expensive to alter priority sequence (note: all loads are prioritized)
- Hot water migration/gravity flow possible in return line. Flow check, Spring loaded check valve or thermal trap required in return riser.
- Critical on site installation (Tee spacing and pipe sizing)

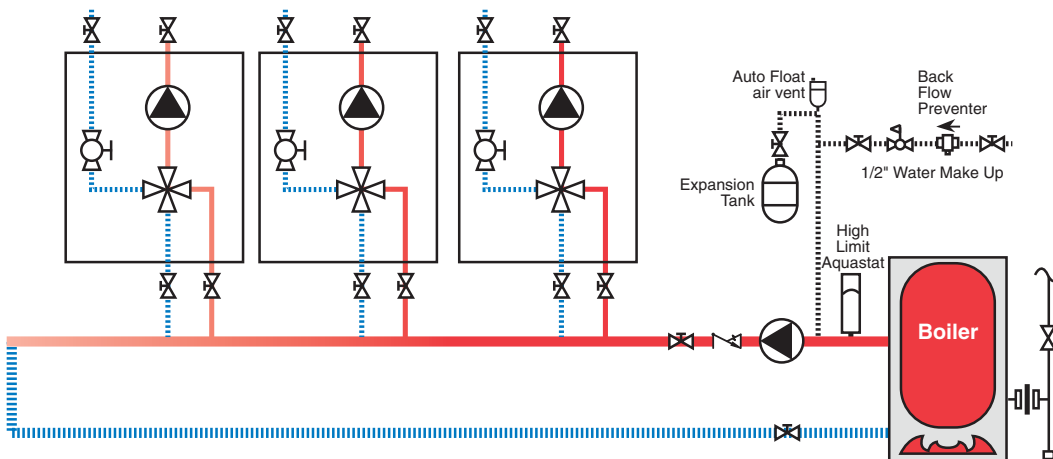

Panel Wiring



- Wiring should be done by a qualified electrician and should meet local codes and jurisdictions.

**Auxiliary Contacts** The auxiliary contact set is dry, meaning no supply of power is present at the terminal. The maximum allowable load is 1.5A. The auxiliary dry contact located on the terminal is to switch another device (ie. the heat source) when there is a call for heat from any zone.

Wiring Diagram

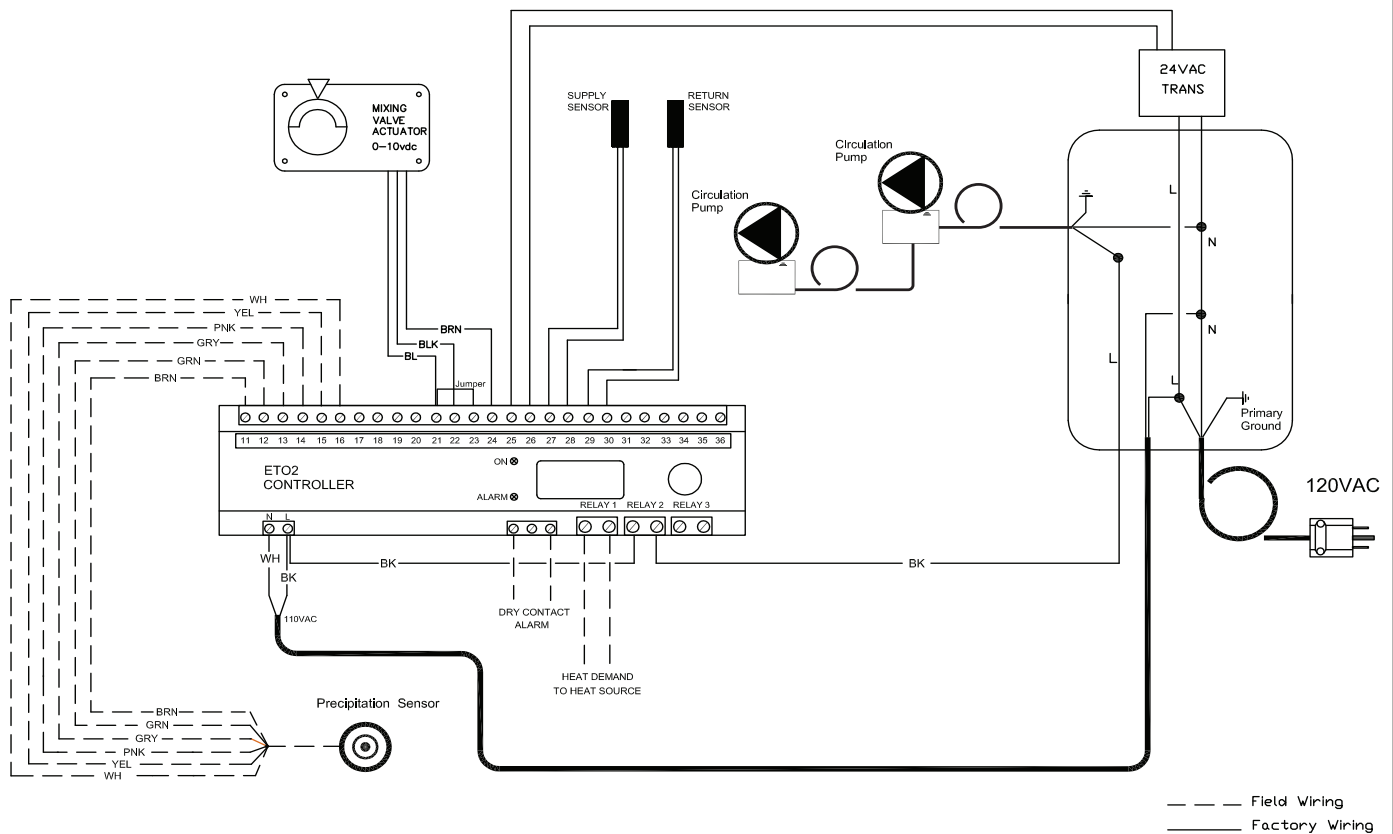

Panel Control Sequence

- Step 1** When the Precipitation Sensor ⑤ detects temperature below SET TEMP 1 (warm weather shutdown), the System Controller ① will activate. It will start the Primary ② and Secondary ③ Circulators, close the Auxiliary Terminals ④ for 1 minute every 15 minutes to check the return water temperature. If the return water temperature is below the minimum return water temperature (MIN WATER) the System Controller will start the Primary ② and Secondary ③ Circulators, close the Auxiliary Terminals ④, and open the mixing valve ⑥ to increase the return water temperature to the required level (MIN WATER).
- Step 2** When the Precipitation Sensor ⑤ detects snow fall, the System Controller ① will start the Primary ② and Secondary ③ Circulators, close the Auxiliary Terminals ④, and open the mixing valve ⑥ to increase the flow temperature to the maximum supply water temperature (MAX WATER). When no more snow is detected by the Precipitation Sensor ⑤, the System Controller ① continues to operate the system for an additional user adjustable period of time (default 2 h; AFTERRUN 1).
- Step 3** When the Precipitation Sensor ⑤ detects temperature below OFF TEMP 1 (cold weather cutoff), the System Controller ① will be in standby mode.

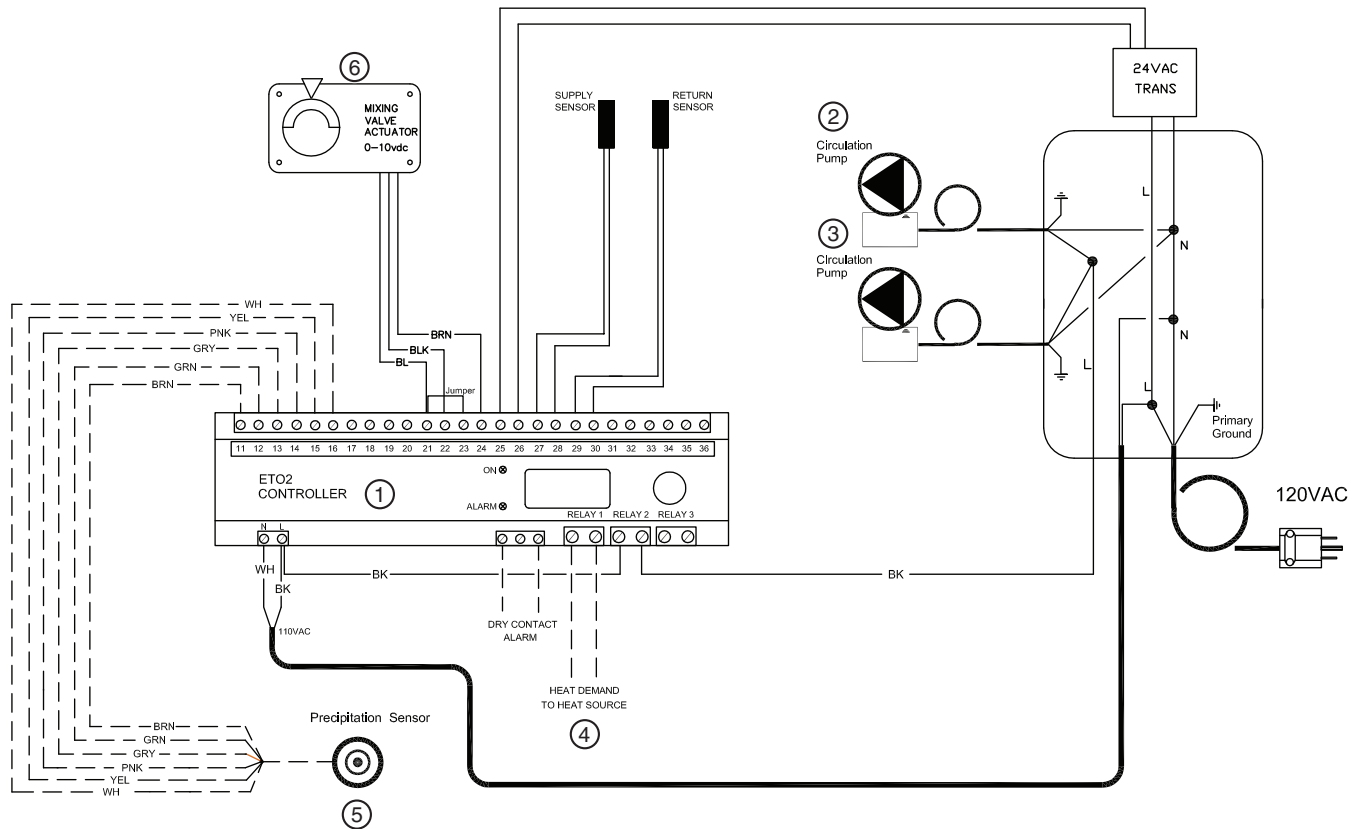

## System Controller

The system controller has been setup at the factory. Minimal or no adjustments should be required for operation.

### Glossary:

Zone 1, 2: Independent heating zones in which ice and snow can be melted. SMP panel only uses Zone 1.

Encoder button: Button which can be turned or pressed to easily configure the settings.

ETOG: DRVWSNS-SS embedded sensor for detecting moisture and temperature.

ETOR: Not used (Gutter sensor for detecting moisture.)

ETF: Not used (Outdoor sensor for detecting temperature.)

Y/Δ: Not used (2-stage control of electric heating systems.)

Afterrun: The heat provided by the system for a specified length of time after the moisture/temperature signal has been eliminated by a heating cycle.

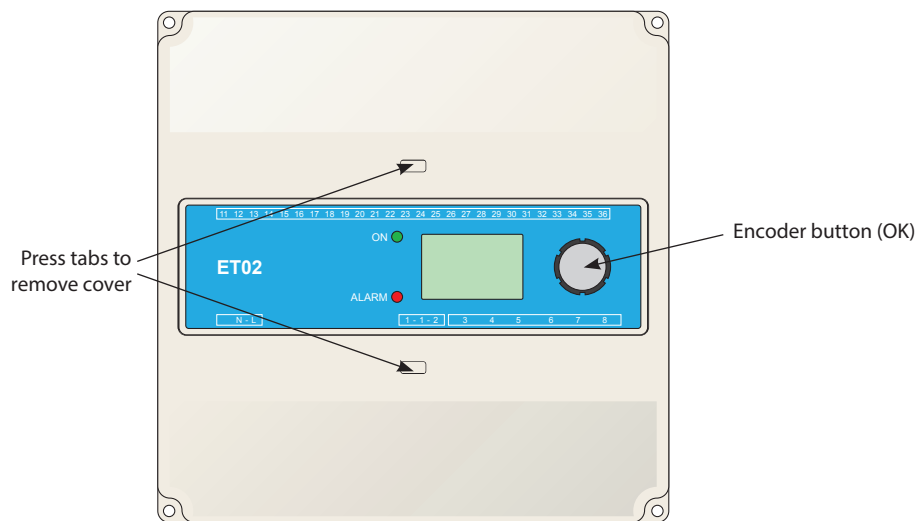

### Operation

ETO2 system controller is equipped with an easily operated encoder button (press and turn) and a display which describes the current situation. The display is backlit and is illuminated by pressing the encoder button (OK). The illumination is automatically switched off after 30 seconds.

Press the encoder button and the main menu will be shown on the display. Turn the button to scroll through the options. Not all the options are shown on the display at once, but they can be accessed by turning the encoder button.

Press encoder button to select a highlighted option.



**Startup** (this has already been done at the factory)

<b>SELECT SCALE:</b>	
<b>CELSIUS</b>	
FAHRENHEIT	

When the ETO2 system controller is switched on for the first time, Celsius or Fahrenheit must be selected. Turn the encoder button until the desired temperature scale is highlighted. Press encoder button to set selection.

<b>SENSOR 1:</b>	
<b>ETOG</b>	
ETOR	

SENSOR 1 is shown on the display, allowing the type of sensor connected for input 1 to be selected:

ETOG: DRVWSNS-SS embedded sensor  
 ETOR: Not applicable (Gutter sensor + outdoor sensor)  
 Press encoder button to set selection.

<b>SENSOR 2:</b>	
<b>OFF</b>	
ETOG	

SENSOR 2 is then shown on the display, allowing the type of sensor connected for input 2 to be selected. If no sensor is connected for input 2, OFF must be selected. Press encoder button to set selection.

<b>OUTDOOR SENSOR</b>	
<b>OFF</b>	
ETF	

Select if outdoor sensor ETF is connected terminals 31-32. If none sensor ETF is connected, OFF must be selected. Press encoder button to set selection.

<b>APPLICATION:</b>	
<b>ELECTRIC 1-ZONE</b>	
ELECTRIC 2-ZONE	
ELECTRIC 2-STEP	
WATER BASED	

Select the application type by turning the encoder button and pressing OK.  
 ELECTRIC 1-ZONE : 1 zone electric/heating control/simple water based  
 ELECTRIC 2-ZONE: 2 zones individual electrical heating control/simple waterbased  
 ELECTRIC 2-STEP : 2 stage electric heating control (Y/Δ) for 1 zone.  
 WATERBASED: 1 zone waterbed heating control with supply water control.

Select the appropriate option and press OK. The system is now set up and will begin operating fully automatically in accordance with the pre-configured standard program, see **FACTORY SETTINGS**. Alternative settings can also be made, see **SETTINGS**.

<b>ZONE 1 HEAT</b>	<b>OFF</b>
<b>ZONE 2 HEAT</b>	<b>OFF</b>
<b>AFTERRUN 1</b>	<b>0.00</b>
<b>AFTERRUN 2</b>	<b>0.00</b>
<b>STANDBY</b>	<b>OFF</b>

Status and afterrun data for zones 1 and 2 are now shown on the display.

## Main Menu

<b>ZONE 1</b>	<b>OFF</b>
<b>ZONE 2</b>	<b>OFF</b>
<b>SENSOR 1</b>	<b>##.#°C</b>
<b>SENSOR 2</b>	<b>##.#°C</b>
<b>MOIST 1</b>	<b>NO</b>
<b>MOIST 2</b>	<b>NO</b>
<b>OUT. TEMP</b>	<b>##.#°C</b>
<b>SUPPLY W.</b>	<b>##.#°C</b>
<b>RETURN W.</b>	<b>##.#°C</b>
<b>ALARM</b>	<b>NO</b>
<b>SHOW INFO</b>	
<b>SETUP</b>	
<b>RESTART</b>	
<b>EXIT</b>	

## Display Texts

<b>ZONE 1</b>	<b>OFF</b>	Heating zone 1 active (ON) or inactive (OFF)
<b>ZONE 2</b>	<b>OFF</b>	Not used. Heating zone 2 active (ON) or inactive (OFF)
<b>SENSOR 1</b>	<b>##.#°C</b>	Sensor 1 temperature, only with ETOG sensor
<b>SENSOR 2</b>	<b>##.#°C</b>	Not used. Sensor 2 temperature, only with ETOG sensor
<b>MOIST 1</b>	<b>NO</b>	Sensor 1 moisture
<b>MOIST 2</b>	<b>NO</b>	Not used. Sensor 2 moisture
<b>OUT. TEMP</b>	<b>##.#°C</b>	Not used. Outdoor temperature, ETF
<b>SUPPLY W.</b>	<b>##.#°C</b>	Supply water temperature, only water-based application
<b>RETURN W.</b>	<b>##.#°C</b>	Return water temperature, only water-based application
<b>ALARM</b>	<b>NO</b>	Fault message, fault type will be displayed. Red LED on front of unit will flash.
<b>SHOW INFO</b>		Application Info
<b>APP:</b>	<b>WATER</b>	Application type: electric or water-based heating
<b>SW VERSION</b>	<b>1.00</b>	Software version
<b>SENSOR 1</b>	<b>ETOG</b>	Sensor type, sensor 1
<b>SENSOR 2</b>	<b>OFF</b>	Not used. Sensor type, sensor 2
<b>SENSOR ETF</b>	<b>OFF</b>	Not used. ETF sensor connected
<b>EXIT</b>		Return to main menu

**SETUP**

## Settings

Please note that incorrect sensor setup may lead to insufficient ice and snow melting.

**FORCE HEAT OFF**

Manual start of forced heat. Press OK and select ON to start Forced heat. ETO2 controller will heat in the pre-programmed afterrun time, see AFTERRUN 1 and 2.

**SELECT SCALE C**

Whether temperature is to be displayed in Celsius (C) or Fahrenheit (F) can be selected here. Select the required scale and press OK. Press OK to return to the SETUP menu.

**SET TEMP 1 5.0C**

Set temperature to Zone 1: The maximum temperature at which ice and snow should be melted can be set here (Warm Weather Shut Down). Set the required temperature and press OK.

**SET TEMP 2 3.0C**

Not used. Set temperature to Zone 2: The maximum temperature at which ice and snow should be melted can be set here. Set the required temperature and press OK.

**OFF TEMP 1 -10.0C**

Lowest operating limit Zone 1 : From set temperature to lowest operating limit, the ETO2 will operate in normal mode (Cold Weather Cut Off). Below this temperature it will be in stand by mode. To change the OFF temperature, press OK and turn the encoder button to the desired value, confirm with OK.

**OFF TEMP 2 -10.0C**

Not used. Lowest operating limit zone 2 can be set here. To change the OFF temperature press OK and turn the encoder button to the desired value, confirm with OK.

**AFTERRUN 1 2:0**

Afterrun time Zone 1: An afterrun duration of between 0 and 18 hours can be set here. The system will continue to provide heat for the specified time after the moisture/temperature signal has been eliminated by a heating cycle. Use the encoder button to set the required afterrun time and press OK.

**AFTERRUN 2 2:0**

Not used. Afterrun time Zone 2: An afterrun duration of between 0 and 18 hours can be set here. Use the encoder button to set the required afterrun time and press OK.

**OFFSET T1 0.0C**

Zone 1 temperature can be calibrated here. The temperature recorded by the ETOG sensor can be adjusted so that the exact temperature is displayed on ETO2. Measure the temperature beside the sensor using a thermometer. Adjust the necessary offset using the encoder button. Press OK.

**OFFSET T2 0.0C**

Not used. Zone 2 temperature can be calibrated in the same way here. Adjust the necessary offset using the encoder button. Press OK.

**OFFSET OUT. 0.0C**

Not used. Outdoor temperature can be calibrated here. The temperature recorded by the ETF outdoor sensor can be adjusted so that the exact temperature is displayed on ETO2. Measure the temperature beside the sensor using a thermometer. Adjust the necessary offset using the encoder button. Press OK.

**MIN WATER 5.0C**

The minimum return water temperature can be set here. Set the required minimum temperature and press OK. This menu option is only available when water-based heating is used.

**MAX WATER 55.0C**

The maximum supply water temperature can be set here. Set the required maximum temperature and press OK. This menu option is only available when water-based heating is used.

**SENSOR HEAT OFF**

In special options or extreme cold weather the sensor heat can be selected on continuously. Select ON and press OK.

**MOIST CTRL ON**

The moist control on sensor can switches off here. The thermostat will only control by the set temperature, see SET TEMP. Select OFF for switch off the moist control and press OK.

**FACTORY RESET**

All ETO2 factory settings can be restored here. Selecting this option deletes all customized settings.

**REINSTALL**

Whether setup failure in startup menu, or new hardware connection has been done, the primary setup must be changed in STARTUP menu. Select PASSWORD and turn the encoder button to the factor code (1202) The controller will then return to the startup menu, see STARTUP.

**REINSTALL PASSWORD XXXX**

**EXIT**

Select this option and press OK to return to the main menu.

**RESTART**

Restart  
When changing the settings or require a new process start, the ETO2 can be restarted in this menu. Keeping your current settings. The ETO2 will go to the initial status display.

**Factory Settings**

Setup	Factory Settings	SMP Panel Settings	Own Settings
Application	Electric	Water Based	
Zone 1	ETOG	ETOG	
Zone 2	OFF	OFF	
Select scale	Celsius	Celsius	
Afterheat time Zone 1	2.00 hours	2.00 hours	
Afterheat time Zone 2	2.00 hours	2.00 hours	
Temp. offset Zone 1	0.0°C / 0.0°F	0.0°C / 0.0°F	
Temp. offset Zone 2	0.0°C / 0.0°F	0.0°C / 0.0°F	
Temp. offset ETF	0.0°C / 0.0°F	0.0°C / 0.0°F	
Set temperature	3.0°C / 37.4°F	5.0°C / 41.0°F	
OFF temperature	OFF	OFF	
Min. water temperature	5°C / 41°F	5°C / 41°F	
Max. water temperature	55°C / 131°F	55°C / 131°F	

## Troubleshooting

Problem	Check / Verify	Possible Cause
<b>Low Temperature Within Snow Melt System (Snow and ice not melting)</b>	Water on the snow/ice detector.	If the snow/ice detector is dry, it may need to be relocated.
	Outdoor temperature is above SET TEMP 1.	System may be in Warm Weather Shut Down. Increase SET TEMP 1.
	Outdoor temperature is below OFF TEMP 1.	System may be in Cold Weather Cut Off. Decrease OFF TEMP 1. Or turn off.
	The panel fails to turn on.	The panel may not be powered. Check if the power module is in the ON position and there is power to the panel.
	The motor actuator fails to open during a call for heat.	The motor actuator may have been left in a manual position, see page 12.
	Without power to the panel take an Ohm reading across each of the sensors. See Testing the Sensors on the next page.	A sensor may be defective. Replace sensor.
	Low supply mixed fluid temperature.	Check heat demand is wired to boiler.
	Wiring from heat source to snow melt panel.	Check that the wiring is done properly. Consult qualified electrician prior to alteration of wiring between heat source and snow melt panel.
	Output of heat source is unable to meet demand of the required system.	Compare output of heat source to the requirements of the snow melting system.
	Circulator is not on during a call for heat. (Use a stethoscope or similar device to verify)	The system controller or circulator may be defective or the cut off temperature is not set properly.
<b>Excessive High Temperature Within Snow Melt System</b>	Check current settings of the system controller.	Adjust the settings on the system controller appropriately.
	High supply mixed fluid temperature.	Adjust the MAX WATER setting on the system controller appropriately.
	The motor actuator remains open after the thermostat is satisfied.	An obstruction inside the valve is not allowing the actuator to fully close or the system controller is still calling for heat.

## Testing the Sensor

### Precipitation Sensor

Measure resistance between the Precipitation Sensor wires.

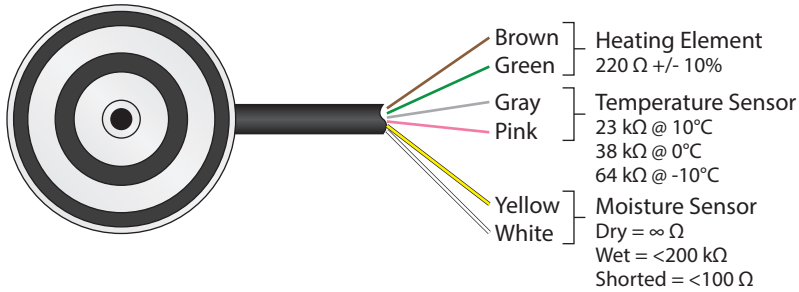

### Supply and Return Sensors

Measure resistance between the sensor wires and compare to the NTC 12k resistance table below.

Celsius	Fahrenheit	Resistance
-20°C	-4°F	112246Ω
-10°C	14°F	63929Ω
0°C	32°F	37942Ω
5°C	41°F	29645Ω
10°C	50°F	23364Ω
11°C	51.8°F	22300Ω
12°C	53.6°F	21292Ω
13°C	55.4°F	20335Ω
14°C	57.2°F	19428Ω
15°C	59°F	18567Ω
16°C	60.8°F	17750Ω
17°C	62.6°F	16974Ω
18°C	64.4°F	16237Ω
19°C	66.2°F	15537Ω
20°C	68°F	14871Ω
21°C	69.8°F	14238Ω
22°C	71.6°F	13636Ω
23°C	73.4°F	13064Ω
24°C	75.2°F	12519Ω
25°C	77°F	12000Ω
26°C	78.8°F	11506Ω
27°C	80.6°F	11035Ω
28°C	82.4°F	10587Ω
29°C	84.2°F	10159Ω
30°C	86°F	9752Ω
35°C	95°F	7978Ω
40°C	104°F	6569Ω
45°C	113°F	5442Ω
50°C	122°F	4535Ω
55°C	131°F	3800Ω
60°C	140°F	3201Ω
70°C	158°F	2306Ω
80°C	176°F	1692Ω
90°C	194°F	1263Ω
100°C	212°F	958Ω



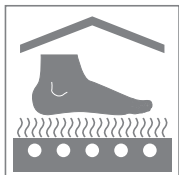

### **Heat Link<sup>®</sup> Canada**

Manufactured & distributed by HeatLink Group Inc.

**Head Office:**

4603E - 13<sup>th</sup> Street N.E.  
Calgary, Alberta, T2E 6M3

Toll Free: 1-800-661-5332  
International Phone: +1 (403) 250-3432  
Fax: 1-866-450-1155

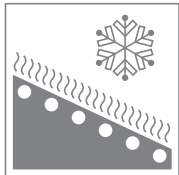

### **Heat Link<sup>®</sup> China**

Distributed by Cathay-Links International

Phone: 852-25693213  
Fax: 852-25359271

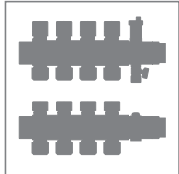

### **Heat Link<sup>®</sup> Ireland**

Distributed by Jamoni Ltd.

Phone: 057 - 932 4062  
Fax: 057 - 932 4063  
Freephone: 1800-311338

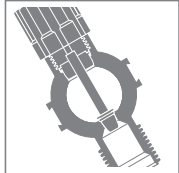

### **Heat Link<sup>®</sup> México**

Distributed by Distribuidora Caisa S.A. de C.V.

Phone: (52-55) 3300-4400  
Fax: (52-55) 3300-4406

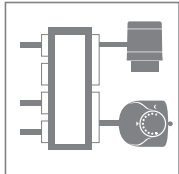

### **Heat Link<sup>®</sup> United States**

Distributed by HeatLink Group Inc.

**USA Distribution Center:**

1000 - 100<sup>th</sup> Street SW, Suite B  
Byron Center, MI, 49315

Toll Free: 1-800-661-5332  
Fax: 1-800-869-6098



**info@heatlink.com**  
**www.heatlink.com**