

Heat Link[®]

Stat Link[®] Technical Guide

Fourth Version

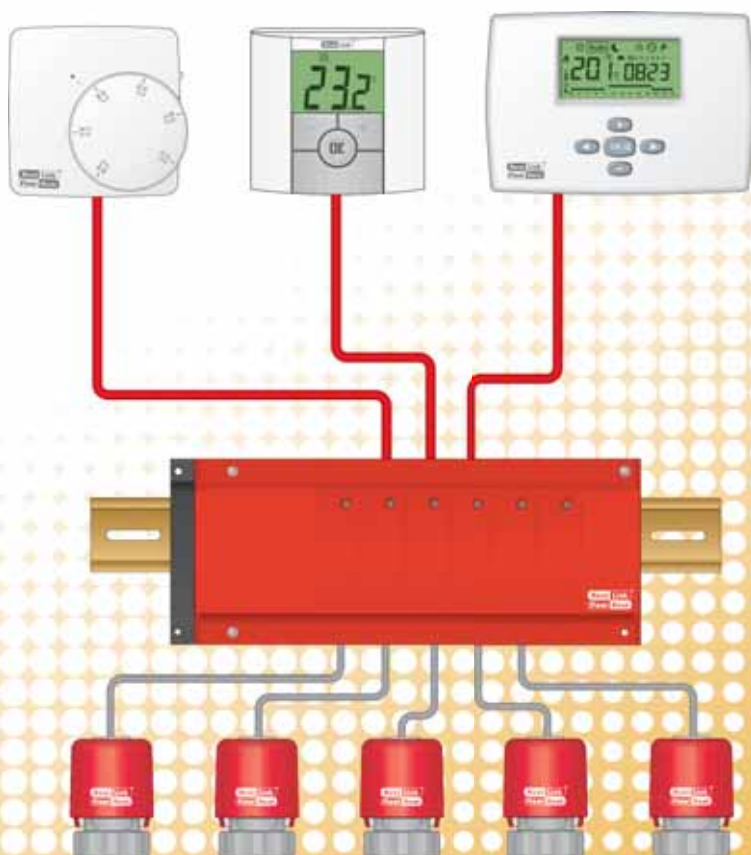

Table of Contents

About Us	3
StatLink® System Components.....	4
Thermostatic Zones Defined.....	6
Color-coded Wiring Schemes	7
StatLink® Wire to Conventional Wire Adapter.....	7
Technical Data	
HeatLink® Electronic Thermostat #46443	8
HeatLink® Digital Thermostat #46544.....	10
HeatLink® Digital Timer Thermostat #46643	12
StatLink® Modules #40200 Series	14
Thermostat & Actuator Operation	16
StatLink® Rough-in Wiring.....	19-21
StatLink® Module Electrical Schematics	
Connecting HeatLink® Thermostat and Actuators to Relay	22
Connecting HeatLink® Thermostat and Actuators to MRIB Panel.....	23
Connecting Third Party 2-wire Thermostat	23
Connecting Third Party 4-wire Thermostat.....	23
Connecting Multiple #40226 Base Modules.....	26-27
Connecting #40226 Module to #31355 Control.....	28-29
HeatLink® Thermostat and Actuator Electrical Schematics	
HeatLink® Thermostat Wiring to Actuator	30
HeatLink® Thermostat Wiring to Actuators with End Switches	31
HeatLink® Digital Timer Thermostat Wiring	32
Connecting Actuators with End Switches to MRIB Panel.....	33
Connecting Actuators with End Switches to #31355 Control	34-35
HeatLink® Digital Heat/Cool Thermostat Interlock Wiring	36-39



About Us

HeatLink is a multi-system supplier of potable water and radiant hydronic heating/cooling and snow melt systems that began as a family-owned business servicing a number of industries, including HVAC.

The company grew to meet the needs of builders, contractors, and architects, and began designing and installing radiant heating systems in 1985. Since then HeatLink has grown into an industry leading manufacturer of radiant heating, cooling, and potable water systems for residential and commercial applications throughout the world.

HeatLink's radiant heating systems create a comfortable and energy efficient environment for living, while our snow melt systems create safer public and private spaces that reduce liability for property owners, reduce maintenance, and ensure accessibility. Our well engineered plumbing systems provide peace of mind for property owners through extensive warranty protection, and enable quick and efficient installations for builders and contractors.

HeatLink has developed and manufactured many industry firsts, such as the "TwistSeal" tool-less manifold in 1996. The company began manufacturing PEX-a tubing in 1998, and now supplies the highest quality PEX-a systems to customers throughout North America, and parts of Europe and Asia.

HeatLink works with a network of experienced and successful partner agencies to meet the design, system installation, and training needs of the construction industry, designers, and architects.

HeatLink was built on a strong family work ethic and value system that remains the foundation for our continuing growth and industry leadership role.

The StatLink® System

Features:

- StatLink® is a modular control system.
- Actuators are pre-wired from factory.
- The StatLink® modules simplify wiring and troubleshooting.
- Temperature setback (both manual & automatic) is available.
- Each component has a heat demand indicator for easy troubleshooting.
- Terminals for up to 4 or 12 actuators per zone.
- One 24V/60VA transformer can power as many as 12 actuators.

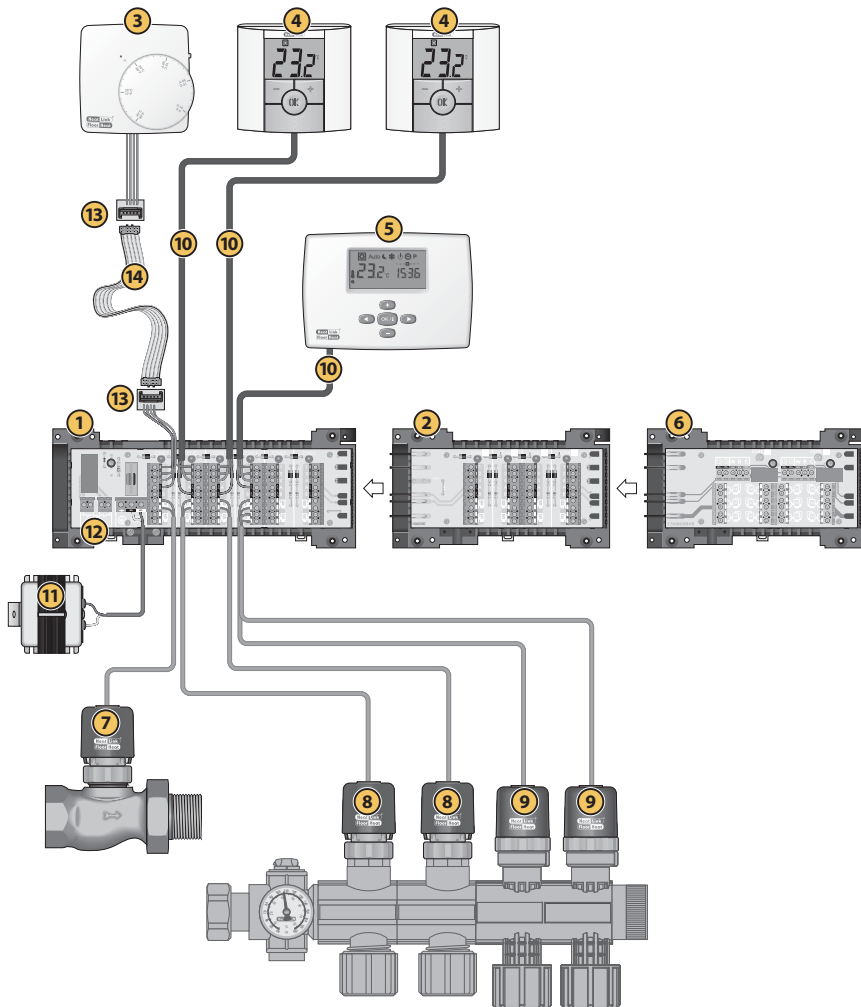

System Components:

- 1 **#40226 6 Zone Base Module**; one (1) is required for each manifold location. **
- 2 **#40234 4 Zone Expansion Module**; required if the manifold supplies more than six zones. One (1) for every four (4) additional zones. **
One (1) thermostat per zone.
- 3 **#46443 Electronic Thermostat**
- 4 **#46544 Digital Thermostat**
- 5 **#46643 Digital Timer Thermostat**; allows for 1 setback schedule.
- 6 **#40242 - 2 Heavy Duty Zone Expansion Module**; 2 zones with up to 12 actuators per zone.
- 7 **#56201 Actuator for #62000 & #63000 series zone valves or #76100 & #76200 series stainless steel manifolds.**
For zone valves, used if one thermostat controls an entire manifold. One (1) valve and one (1) actuator per manifold (thermostat) (if valve cannot be installed see 8).
For stainless steel manifolds, used if one or more loops on a manifold are controlled by a thermostat. One (1) per loop per thermostat.
- 8 **#56200 Actuator for #78200 & #78400 series manifold modules.** Used if one or more loops on a manifold are controlled by a thermostat. One (1) per loop per thermostat.
- 9 **#56202 Actuator for #78300 series supply modules.** Used if one or more loops on a manifold are controlled by a thermostat. One (1) per loop per thermostat.
- 10 Standard AWG 18 cable (not supplied by HeatLink). Thermostat and Module terminals are color coded to match the color wires found in fire-alarm cable (FAS105).
- 11 24 Vac Class II Transformer required (not supplied by HeatLink). Max. 60VA recommended per module block. **
- 12 Dual dry contacts to activate a boiler, pump (via an external 24 Vac relay) or #31000 series control.
- 13 **#43404 5-wire Flat Cable to Standard Wire Adaptor**; utilize existing wiring 14 when upgrading components.

**Max. recommended, 12 actuators per module.

Thermostatic “Zones” Defined

- Zones are areas of **thermostatic control** (which in turn “drive” an actuator).
- Zones **do not** apply to the number of loops in a system.

A zone can be a single valve actuator in front of a manifold being **controlled by one thermostat**. (This still allows for individual room by room and loop by loop temperature adjustment using a flow balancing manifold.)

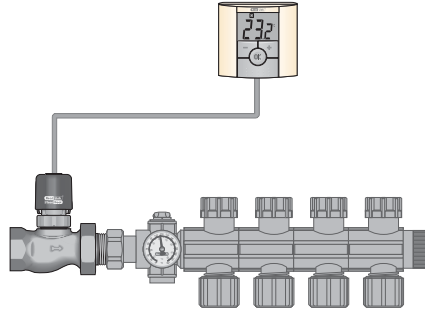

A zone can be a single manifold actuator being **controlled by one thermostat**.

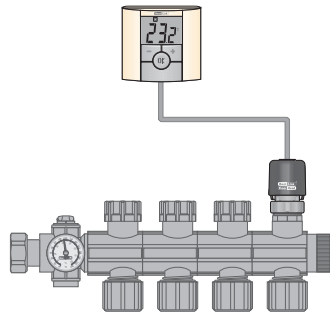

A zone can be multiple manifold actuators being **controlled by one thermostat**.

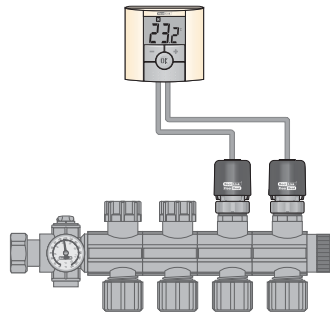

Default and Suggested Alternate Color-coded Wiring Schemes

Wire	FAS105 (red jacket) StatLink® default	Thermostat Wire (white jacket)	LVT Thermostat Wire (brown jacket)
C	green	green	green
R	blue	blue	white
W	red	red	red
Ⓢ	black	white	black

StatLink® Wire to Conventional Wire Adapter #43404

- Utilize existing flat wiring when upgrading components.

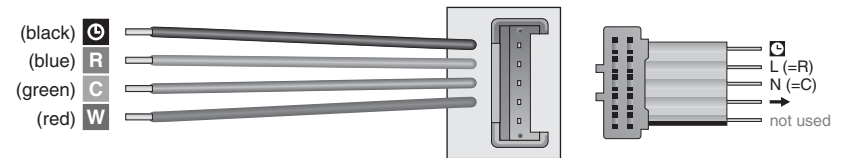

HeatLink® Electronic Thermostat #46443

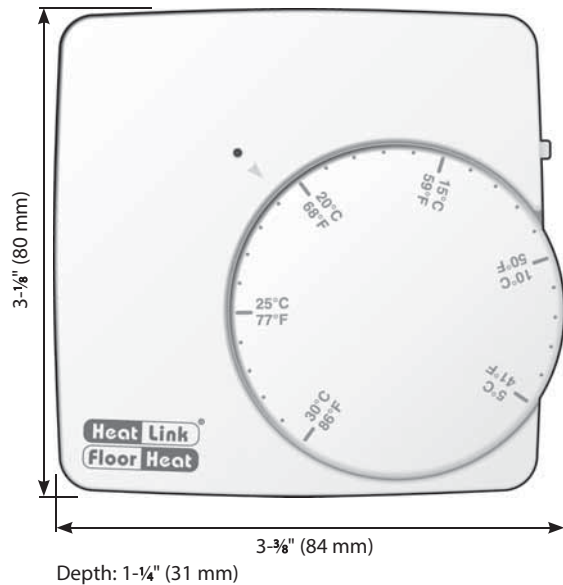

Features:

4 wire electronic thermostat with optional setback.

- LED call for heat indicator.
- Large easy to adjust dial.
- 3 position operation selector switch.
- Manual or automatic (external timer) setback.
- Internal or external sensor operation.

Power: 24 Vac (no battery).

Contacts: 3+1 Wires.

C (power) - 2 terminals for easy direct connection of actuator.

R (power).

W (heat demand via triac [silent operation]).

Ⓢ (setback signal from StatLink [optional]).

NTC (optional external sensor).

Regulation: Analog electronic regulation optimized for high mass heating system controlled by thermoelectric actuators.

Operation: 3 position selector switch: comfort/automatic/setback operation.

Setback: 4°C / 7°F.

Display: Large easy to adjust dial with dual temperature scale.

Specifications

Operating Voltage	24Vac
Power Consumption	0.5 VA max
Operating Temperature	0°C to 50°C / 32°F to 122°F
Setting Temperature	5°C to 30°C / 41°F to 86°F
Measured Temperature Precision	0.1°C / 0.2°F
Output	24Vac triac 15W max
Regulation Characteristics	0.5°C / 0.9°F static differential
Temperature Setback	4°C / 7°F
Protection Class	Class II - IP 30
Temperature Sensor	Internal 10kΩ NTC thermistor Optional external 10kΩ NTC thermistor (sold separately)

HeatLink® Digital Thermostat #46544

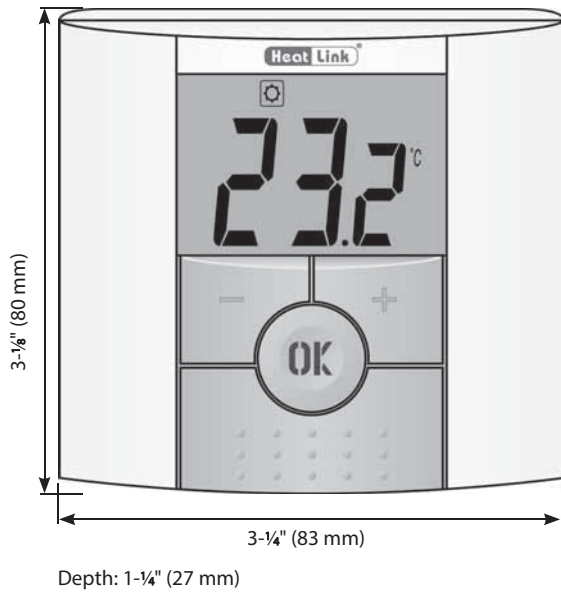

Features:

4 wire PI fully digital electronic setback thermostat.

- Proportional integral temperature regulation.
- Fully menu driven.
- Large display showing current temperature.
- Setpoint display with push of a button.
- Manual or automatic (external timer) setback.
- Floor warming functionality with room, floor or combined operation.

Power: 24 Vac (no battery).

Contacts: 3+1 wires.

C (power).

R (power).

W (heat demand via triac [silent operation]).

Ⓢ (setback signal from StatLink [optional]).

NTC (optional external sensor).

Regulation: Pulse width modulation (PWM) with proportional integral (PI) logic.

Adjustable characteristics for system optimization (high mass, low mass, baseboard, fan coil and cooling).

Combined room/floor: The floor sensor acts as a temperature limiter.

Operation: Menu selectable: automatic/comfort/off/setback/freeze protection/timer operation.

Optional pump exercise functionality.

Display: Temperature in °C or °F.

Large display showing current temperature.

Setpoint display with push of a button.

Shows: mode of operation; call for heat.

Specifications

Operating Voltage	24Vac
Power Consumption	0.5 VA backlight off 1 VA backlight on
Operating Temperature	0°C to 40°C / 32°F to 104°F
Setting Temperature	5°C to 37°C / 41°F to 99°F
Measured Temperature Precision	0.1°C / 0.2°F
Output	24Vac triac 72W max
Regulation Characteristics	Proportional integral (PI) or static differential
Temperature Setback	Adjustable
Protection Class	Class II - IP 30
Temperature Sensor	Internal 10kΩ NTC thermistor Optional external 10kΩ NTC thermistor (sold separately)

HeatLink® Digital Timer Thermostat #46643



Depth: 1-3/8" (35 mm)

Specifications

Operating Voltage	24Vac
Power Consumption	2.5 VA max
Operating Temperature	0°C to 50°C / 32°F to 122°F
Setting Temperature	5°C to 30°C / 41°F to 86°F
Measured Temperature Precision	0.1°C / 0.2°F
Output	24Vac triac 15W max
Regulation Characteristics	Proportional integral (PI) or static differential
Temperature Setback	Adjustable
Protection Class	Class II - IP 30
Temperature Sensor	Internal 10kΩ NTC thermistor Optional external 10kΩ NTC thermistor (sold separately)

Features:

4 wire PI fully digital electronic thermostat with 7 day timer.

- Proportional integral temperature regulation.
- Fully menu driven.
- Large display showing current temperature and time.
- Easy to program 7 day 24 hour timer with 4 user programs and 9 fixed programs.
- Setback signal feedback to StatLink.
- ITCS function for intelligent setback functionality.

Power: 24 Vac (no battery).

Backup: Programs forever.
Clock for 1 day.

Contacts: 3+1 wire.

C (power) - 2 terminals for easy direct connection of actuator.

R (power).

W (heat demand via triac [silent operation]).

Ⓢ (setback signal to StatLink [optional]).

NTC (optional external sensor).

Regulation: Pulse width modulation (PWM) with proportional integral (PI) logic.

Adjustable characteristics for system optimization (high mass, low mass, baseboard, fan coil and cooling).

ITCS function for intelligent setback functionality.

Operation: Menu selectable: standard/automatic/setback/freeze protection operation.

Holiday operation.

Optional pump exercise functionality.

Timer: Easy to program 7 day 24 hour timer.

Programmable in 1 hour increments.

Switchable clock display (am/pm or 24hour).

Featuring 4 user programs and 9 fixed programs.

Display: Temperature in °C or °F.

Large display showing current temperature and time.
Graphic program display.

Setpoint display with push of a button.

Shows: mode of operation; call for heat; active setback program.

StatLink® Modules #40200 Series

Features:

24 Vac modular zone wiring system allowing easy connection of thermostats and actuators.

- LED indicator for each zone.
- Cover with LED viewer.
- Multiple actuators per zone.
- Color coded connections.
- Universal wire connections.
- 2 setback channels.

StatLink® 6 Zone Base Module #40226

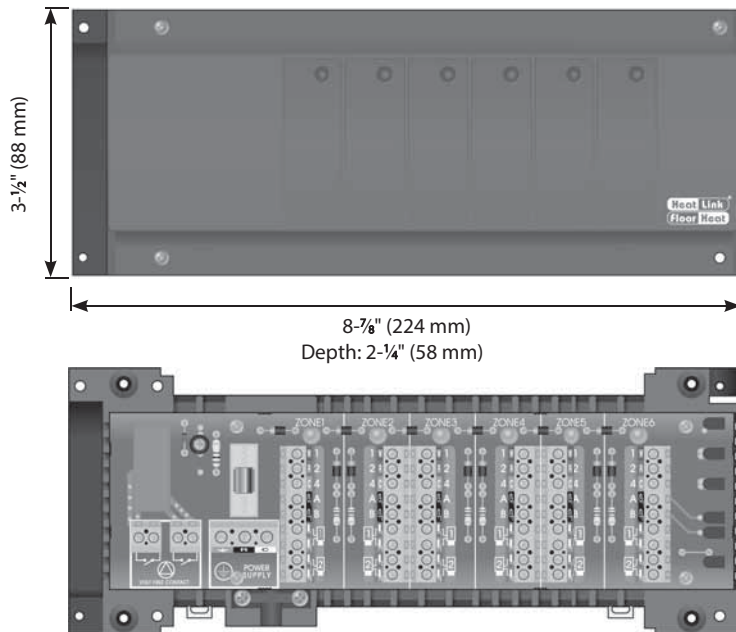

- 24 Vac input; max 60VA; Fused at 2.5A.
- DPST NO Pump relay (no time delays).
- 6 zones.
- Up to 4 actuators per zone (actuators doubled up).
- LED lights to indicate operational status of each zone.
- 2 timer channels.
- Color coded terminals.

StatLink® 4 Zone Expansion Module #40234

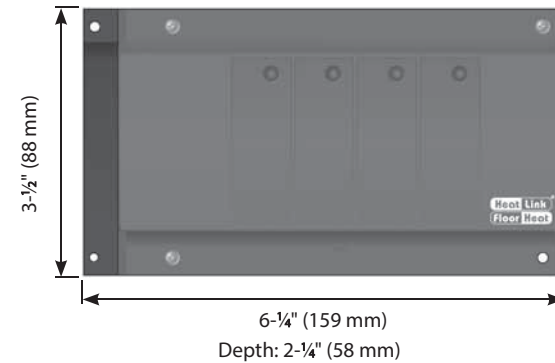

- Plugs directly into base module.
- Zone signal feedback to base module.
- 4 zones.
- Up to 4 actuators per zone (actuators doubled up).
- LED lights to indicate operational status of each zone.
- 2 timer channels.
- Color coded terminals.

StatLink® 2 Heavy Duty Zone Expansion Module #40242

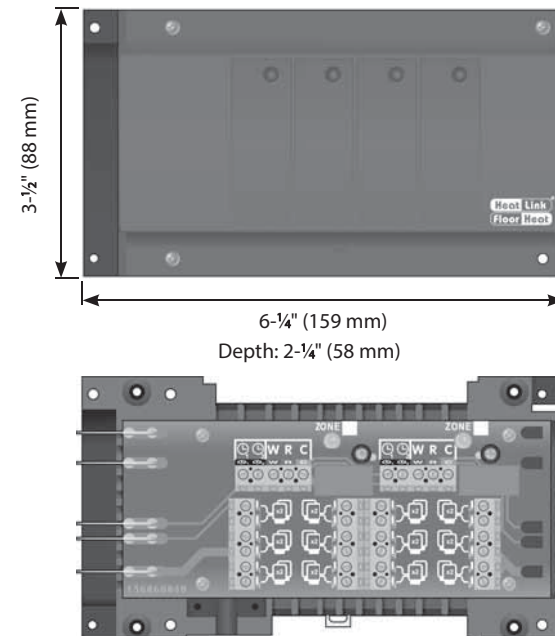

- Same as 40234 Expansion Module but
- 2 zones with up to 12 actuators per zone (actuators doubled up).

Thermostat and Actuator Operation

The HeatLink® #46000 Series Thermostats & StatLink® Modules are integrated components, working in conjunction with #56200 Series Actuators. The digital thermostats work on proportional plus integral (PI) processing, producing a pulse width modulation (PWM) output, that is similar to an analog output such as the one produced by the HeatLink electronic or mechanical thermostats. The PI processing identifies the offset between the actual temperature and the desired set point, within a defined differential that centers at the set point. It adjusts the control action to compensate for the difference, so that the offset can be eventually eliminated. In essence, it works on a set point and a cycle length that is measured either in minutes or in cycles per hour. The thermostats operate once per cycle.

The *on time* in each cycle is determined by the difference between the set point and the actual temperature (the *error*). If the *error* is positive (i.e. the set point is above the actual temperature), the *on time* is increased from 50% of the cycle time, or vice versa. If the actual temperature is right on the set point, the *on time* is exactly 50% of the cycle time. Essentially, PWM thermostats operate for longer, or shorter, *on times* each cycle, depending the degree of error in the actual temperatures.

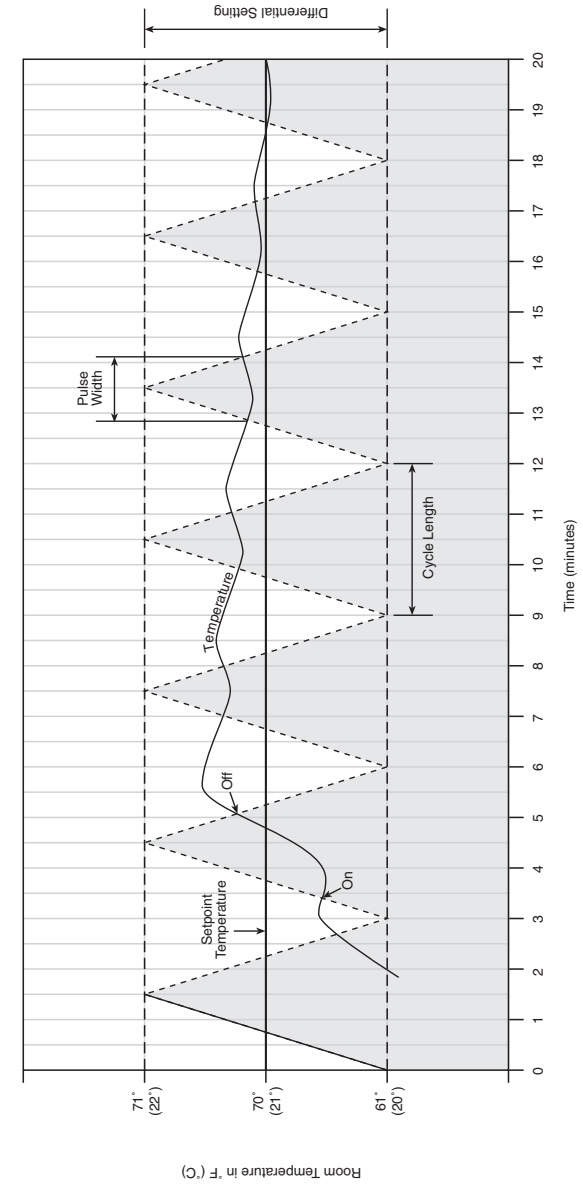

Thermostat and Actuator Operation

The #56200 Series Actuators are non-motorized and activated by an electric current. This current heats a heating element in a wax filled piston chamber that in turn *drives*, or moves, the motor insert pin, as the wax warms up and expands. Thus opening and closing the manifold module or zone valve. The actuator has a *full close to full open* time range of 1.5 to 6 minutes (depending on the residual temperature of the heating element, and the wax piston chamber from the previous cycle).

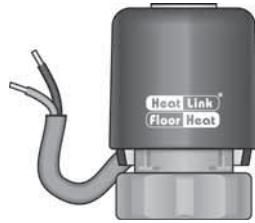

Working in conjunction with slow acting actuators, PWM thermostats are essential for slow responding, high thermal mass systems. *Slow responding* means there is a long delay from when a temperature change is sensed by a thermostat, and after it is turned ON. Likewise, a *high thermal mass system* means that heat continues being released for a long period of time after a thermostat was turned down. If an *ON/OFF thermostat* is used instead, cycles of overheating and underheating will be unavoidable. An *ON/OFF thermostat* turns ON only when the actual temperature is below the desired set point. In a *slow responding system*, the actual temperature can continue to dip even after the thermostat has turned ON. This is because the heat initially applied to the system is being used to stock up the thermal mass instead of warming up the space.



StatLink® Rough-in Wiring (ELECT 1.8)

(C/W 4-WIRE THERMOSTAT TERMINATION AT MANIFOLDS (i.e. FOR MULTIPLE ZONING PER MANIFOLD))

Low Voltage Wiring Only! (See ELECT 1.9 plus ELECT _____ for corresponding schematics.)

- 1 OUTDOOR SENSOR:**
2 wires from side of building (outside wall location; *preferable location to be on the same side of the building where the main occupied rooms are and not near any windows, ventilation openings or artificial heat sources!*) back to mechanical room.
- 2 REMOTE INDOOR SENSOR (i.e. ROOM TEMPERATURE UNIT - RTU)**
2 wires from a main occupied area back to the mechanical room. (Location chosen should reflect the area where the most solar gain will occur).
Note: In some applications R.T.U. may be omitted or substituted with multiple averaged room sensors where a single main occupied area can not be chosen.
- 3 ROOM THERMOSTATS:**
Standard 4-wire to be run from each zone back to the corresponding manifold location. (Rough-in wire 6" above light switch for future access; Drywall overtop to conceal!)
- 4 BASE MODULE:**
2 wires for a 24V power source from each manifold location back to the mechanical room. (Optional wiring: allow for 110V power source to a 24V transformer at each manifold.)
- 5 4 WIRE JUMPER:**
4 wire to be run between each manifold location. This allows for the transfer of both the clock module and pump/boiler relay information from manifold to manifold. See note at bottom of page.

Note: from the last manifold location which has been jumpered in parallel, an additional 2-wire must be returned to the mechanical room for tie-in to the #31355 controller "heat demand" contacts.

StatLink® Rough-in Wiring (ELECT 1.9)

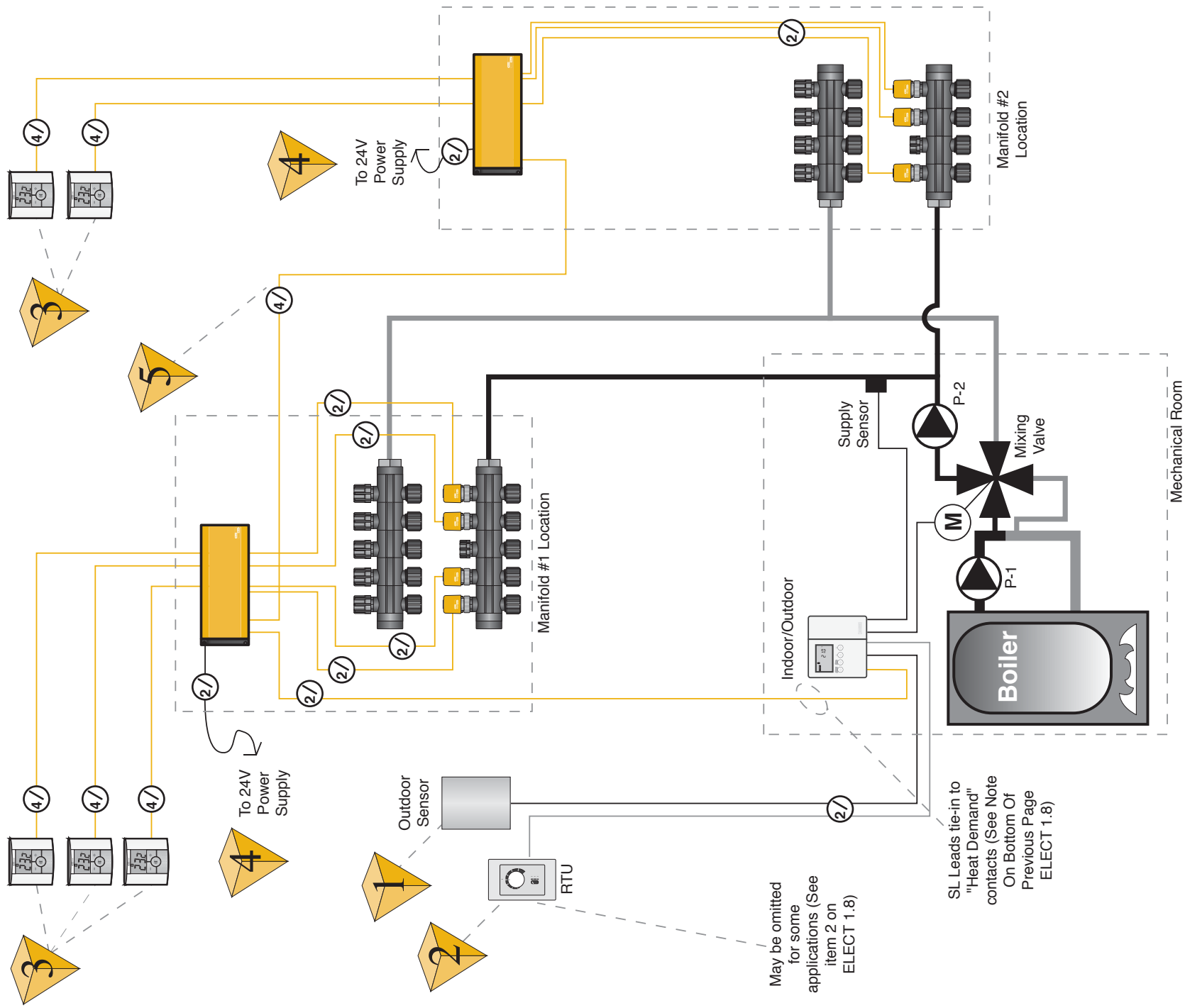

May be omitted for some applications (See item 2 on ELECT 1.8)

SL Leads tie-in to "Heat Demand" contacts (See Note On Bottom Of Previous Page ELECT 1.8)

- 2/ = minimum 18x2 AWG Cable
- 4/ = minimum 18x4 AWG Cable (FAS105)

StatLink® Electrical Schematic

Application: Connecting one zone HeatLink® thermostat and actuators.

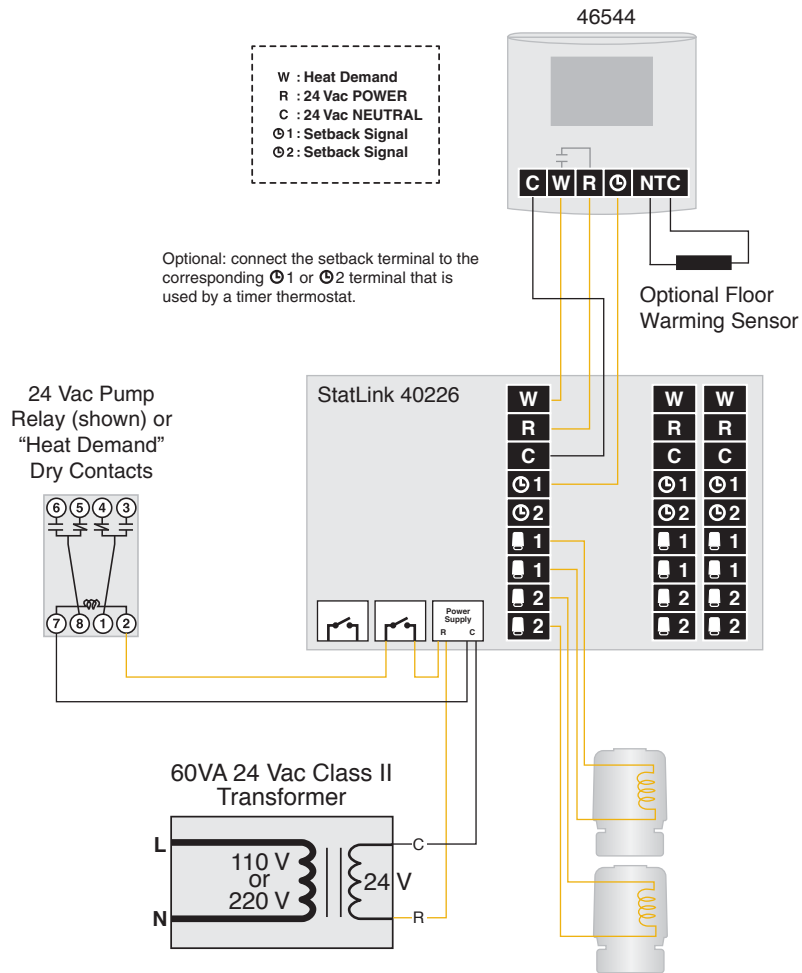

Note: Under some circumstances, the StatLink® 40226 base module may be short cycling the boiler and/or pump. The 40226 dry contacts should be connected to either a time delay relay or outdoor reset control to activate a boiler and/or pump.

StatLink® Electrical Schematic

Application: Connecting StatLink® to a Mechanical Room in a Box Panel.

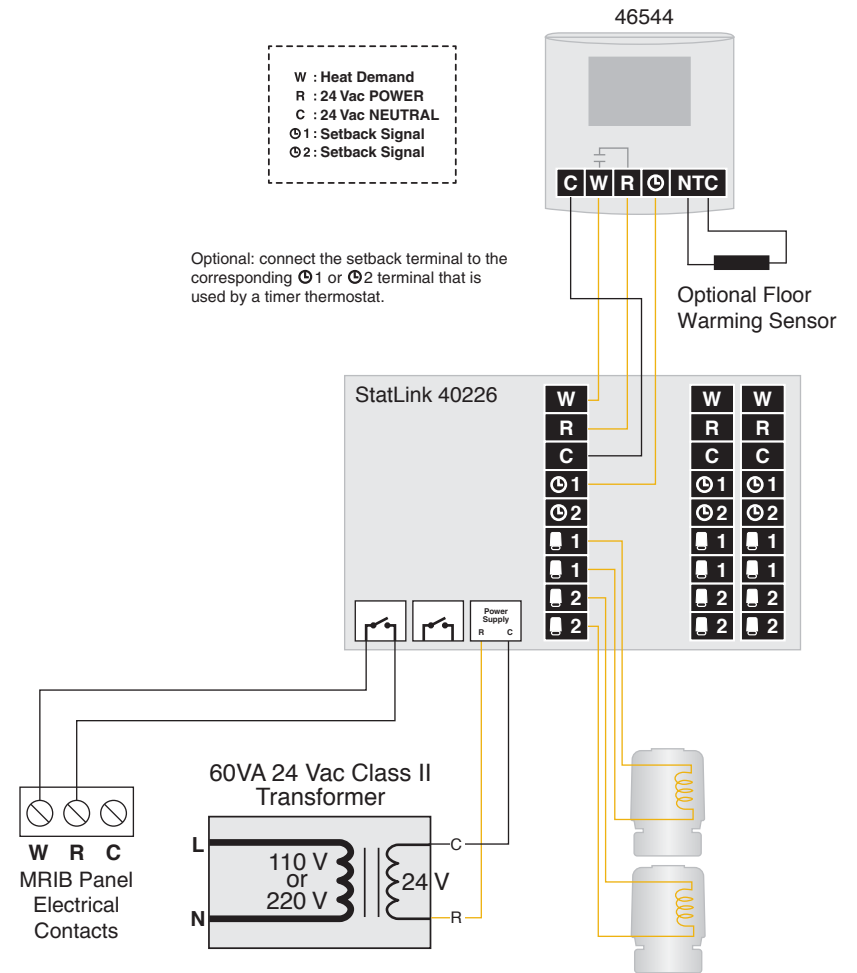

StatLink® Electrical Schematic

Application: Connecting a third party 2-wire mechanical or battery powered thermostat, or a third party 4-wire thermostat to StatLink®.

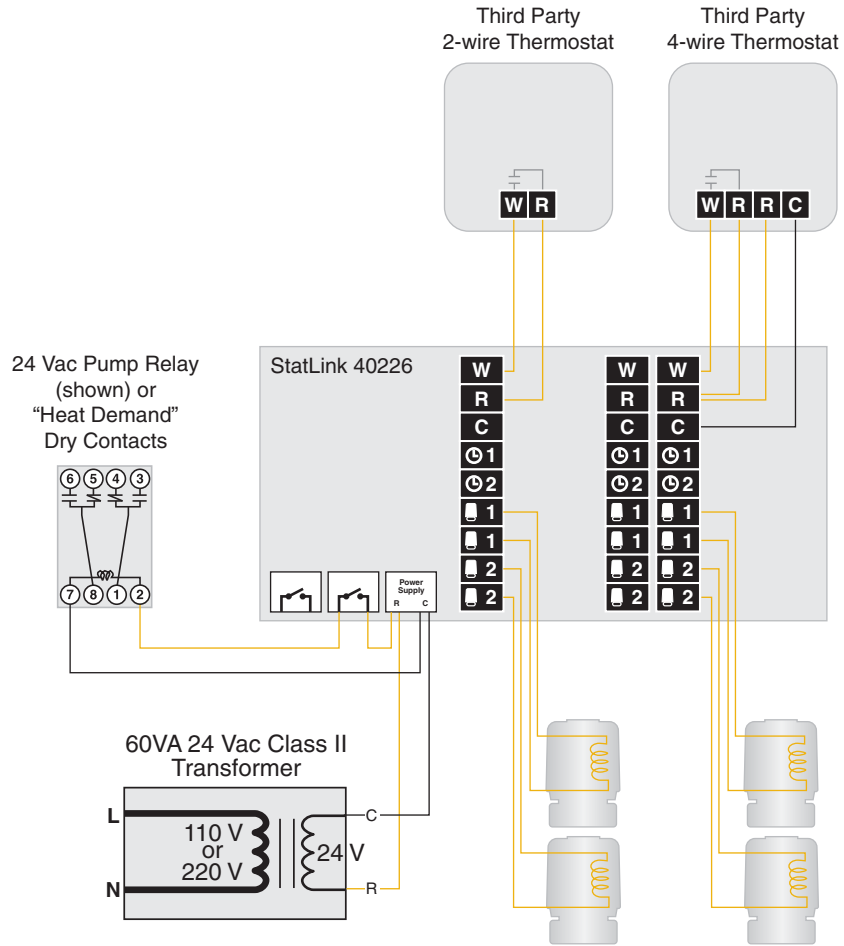

StatLink® Electrical Schematic

Application: Connecting more than 4 actuators to a zone.

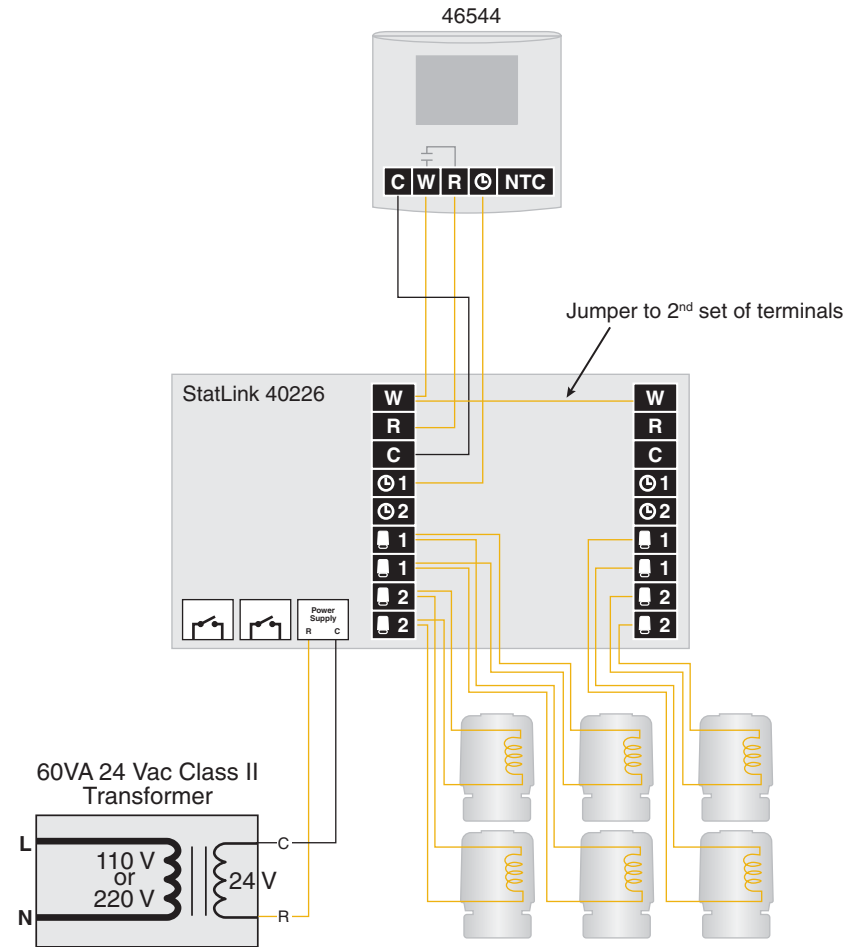

StatLink® Electrical Schematic
Application: Connecting Multiple #40226
 Base Modules together.

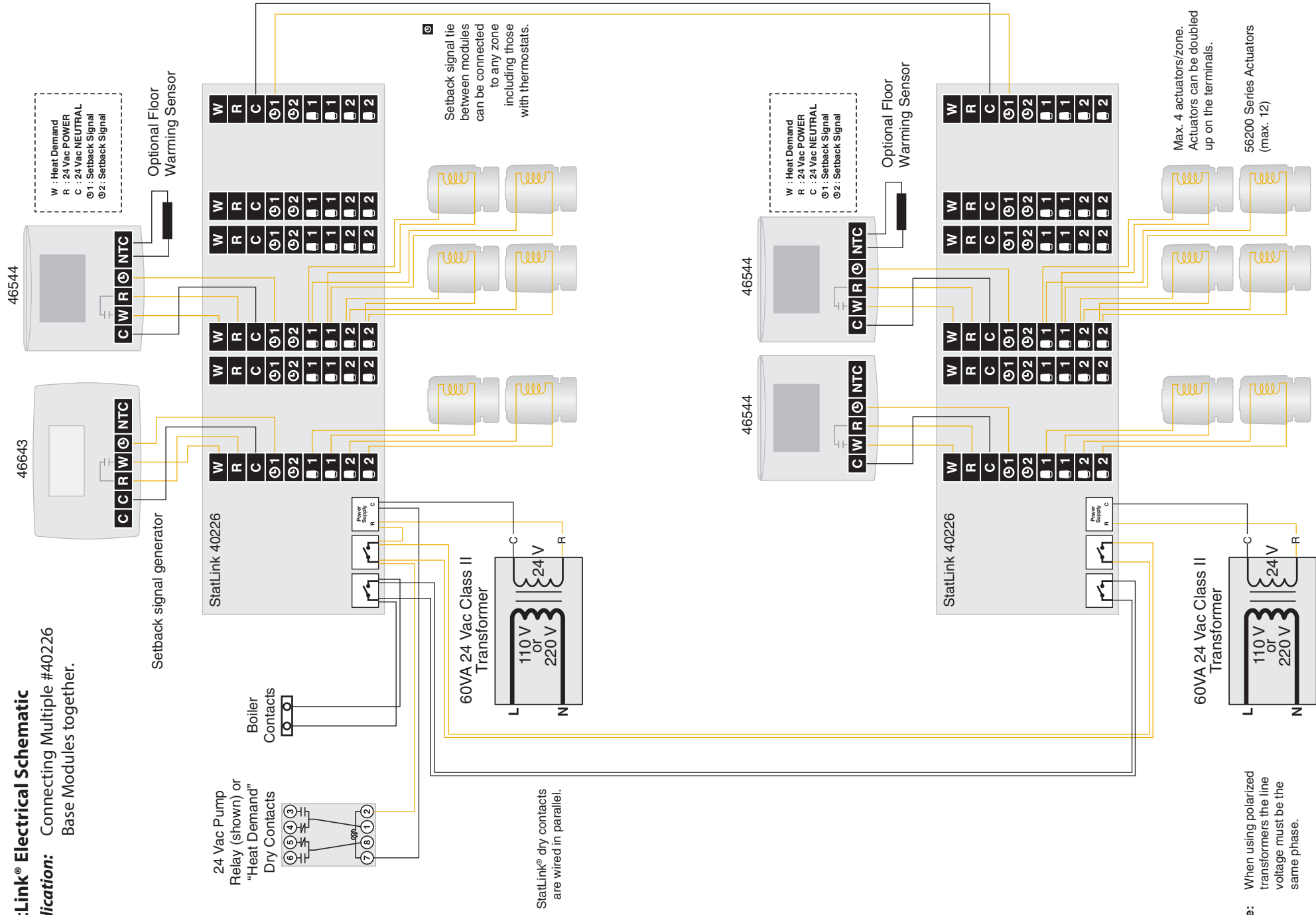

Setback signal tie between modules can be connected to any zone including those with thermostats.

StatLink® dry contacts are wired in parallel.

Note: When using polarized transformers the line voltage must be the same phase.

Electrical Schematic for the #31355 Injection Control

Application: Injection mixing control activating secondary pump for the low temperature manifold circuit.
Boiler c/w system pump (P-1) and primary pump (P-2).

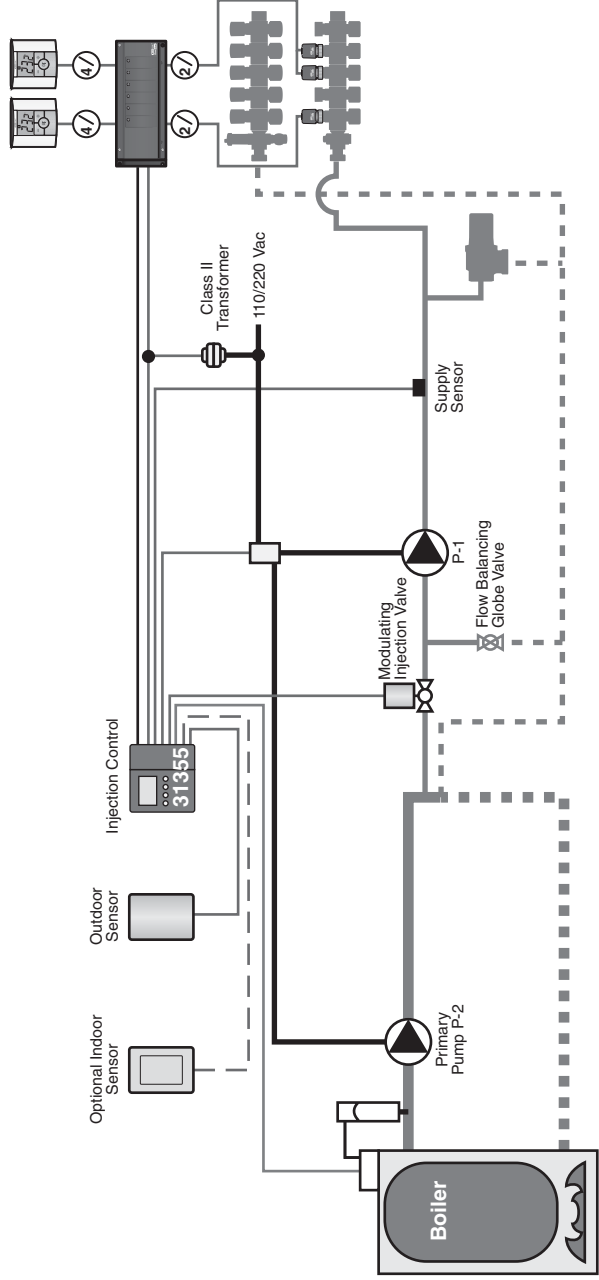

Note: If only an indoor or floor sensor is used without thermostats or StatLink®, then power is required at terminals 1 & 2.

31355 DIP Switches
 Perm. Demand (ON) Ext. Demand
 Setback (ON) Off

R-1 = 45012 Relay (24Vac / 2pole)
 Max. Pump 1/4 HP @ 110Vac
 Max. Pump 1/3 HP @ 220Vac

Note: Thermostats and actuators not shown for simplicity.

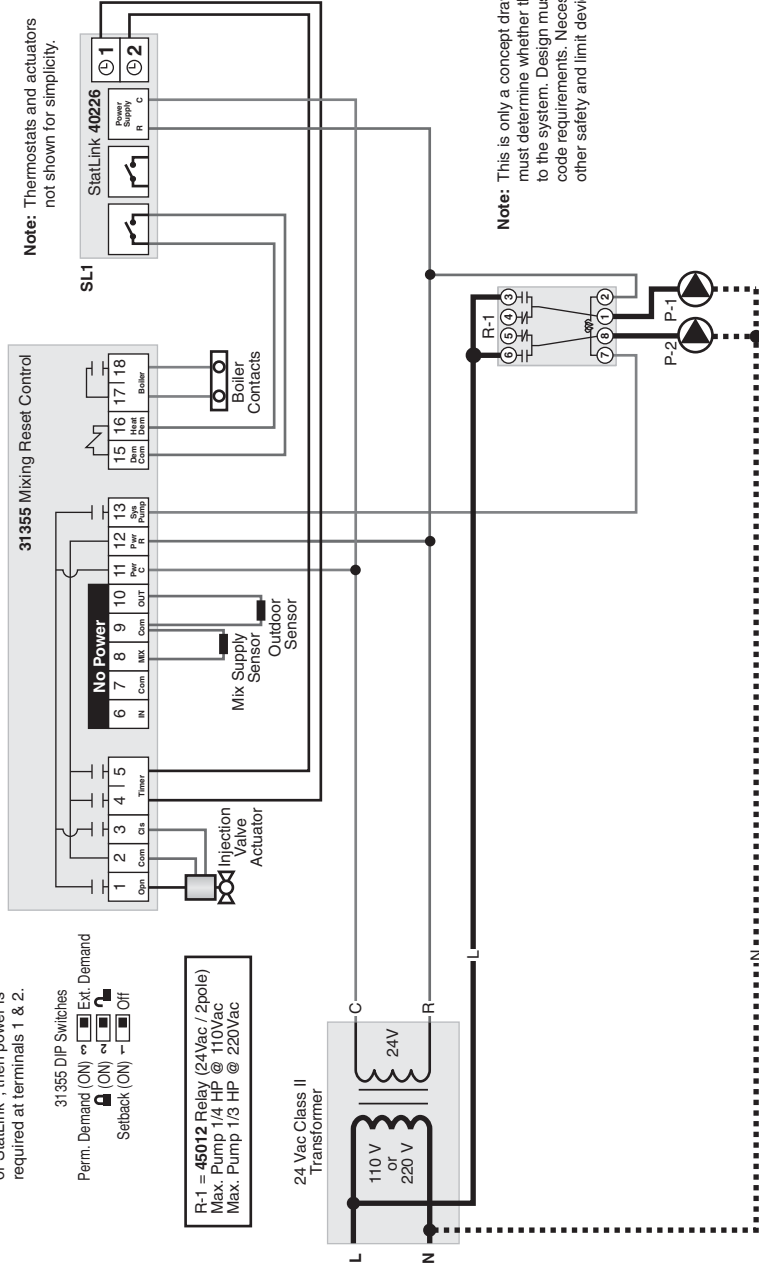

Note: This is only a concept drawing. The designer must determine whether this application applies to the system. Design must comply with local code requirements. Necessary equipment and other safety and limit devices must be added.

HeatLink® Thermostat Wiring

Application: Actuators & thermostats (#46443 or #46544) with internal resistor for heat anticipation.

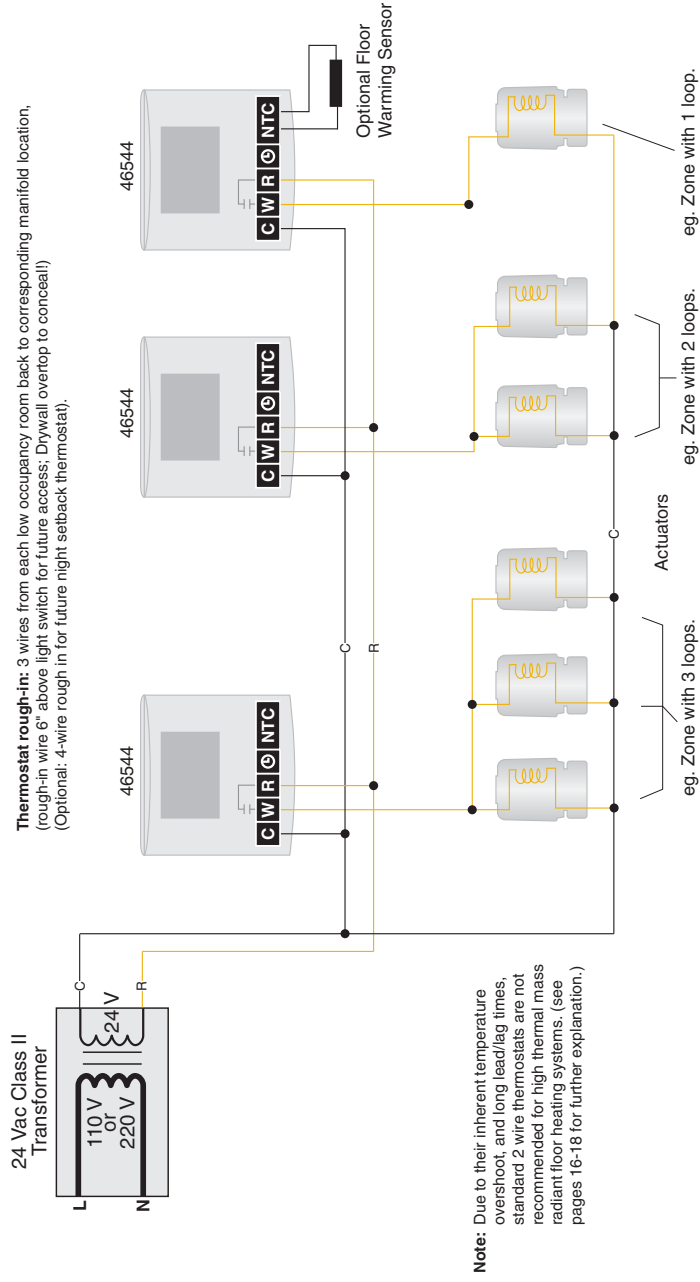

HeatLink® Thermostat Wiring c/w End Switch Tie-in to Relay

Application: Actuators c/w end switch contacts & thermostats (#46443 or #46544) with connection to dry heat demand contacts or heating load relay.

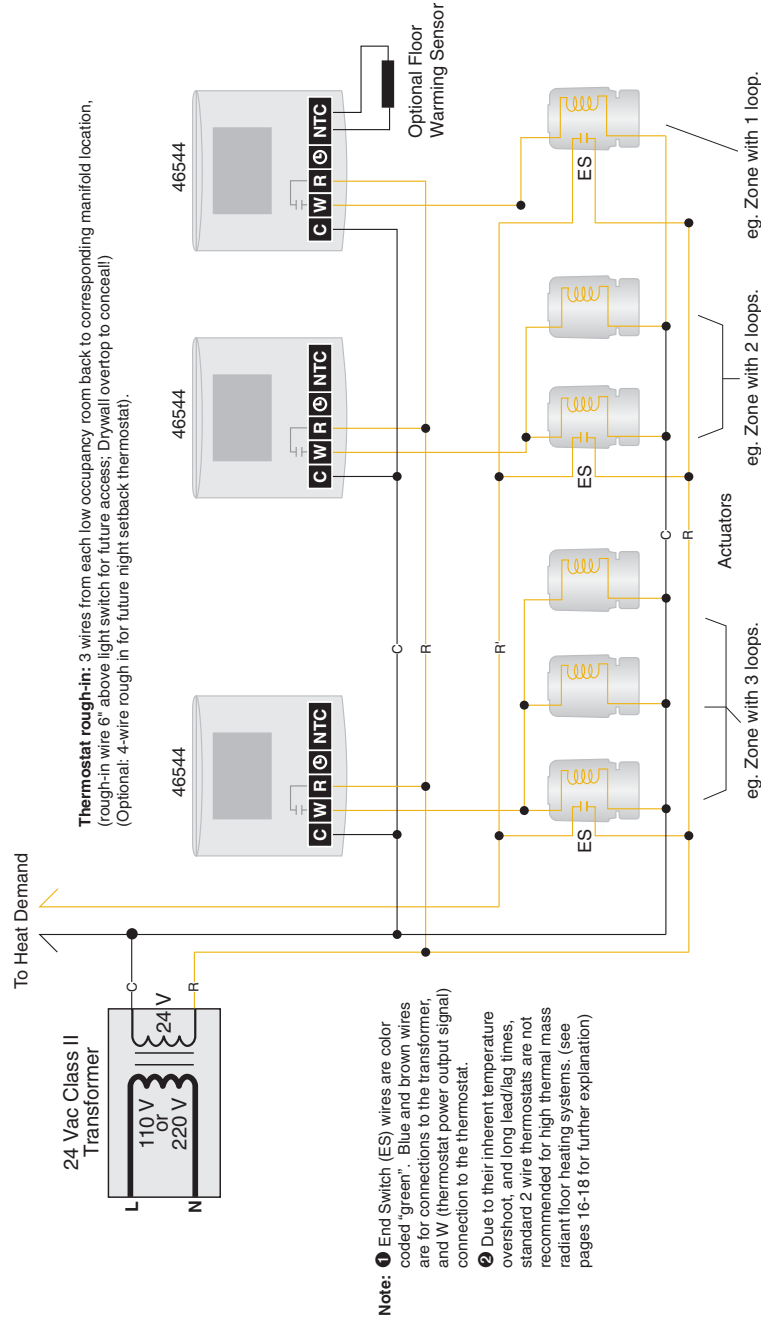

HeatLink® Digital Timer Thermostat (#46643) Wiring

Application: Actuators c/w end switch contacts & thermostats connecting to dry heat demand contacts or heating load relay with setback signal.

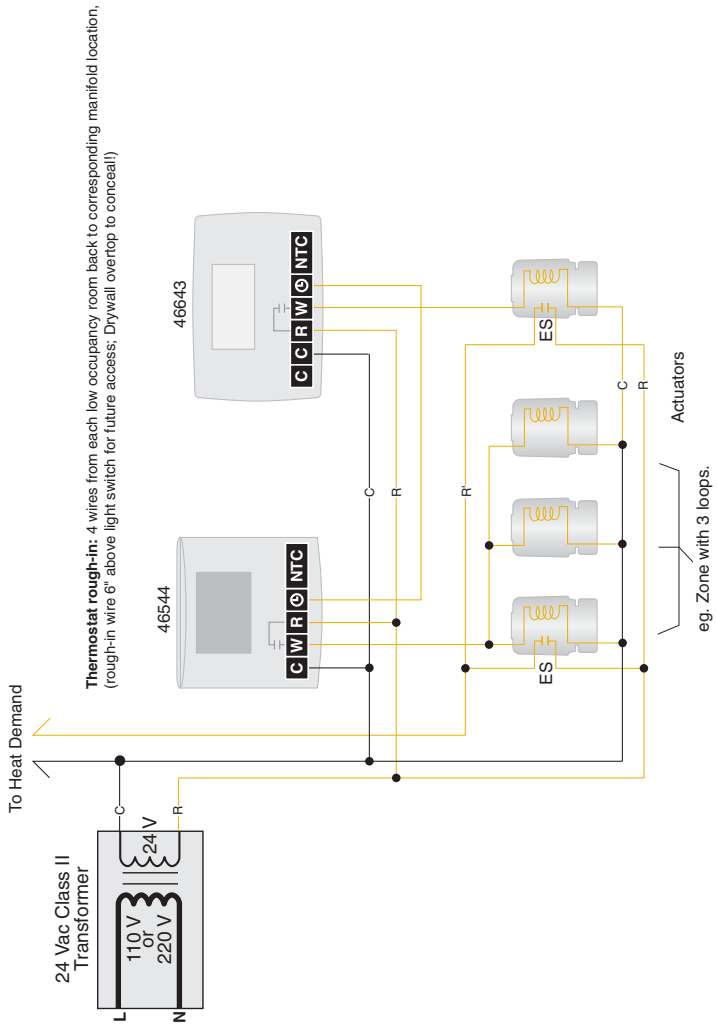

HeatLink® Actuator End Switch Wiring to Panel

Application: Actuators c/w end switch contacts & thermostats connecting to Mechanical Room in a Box Panel.

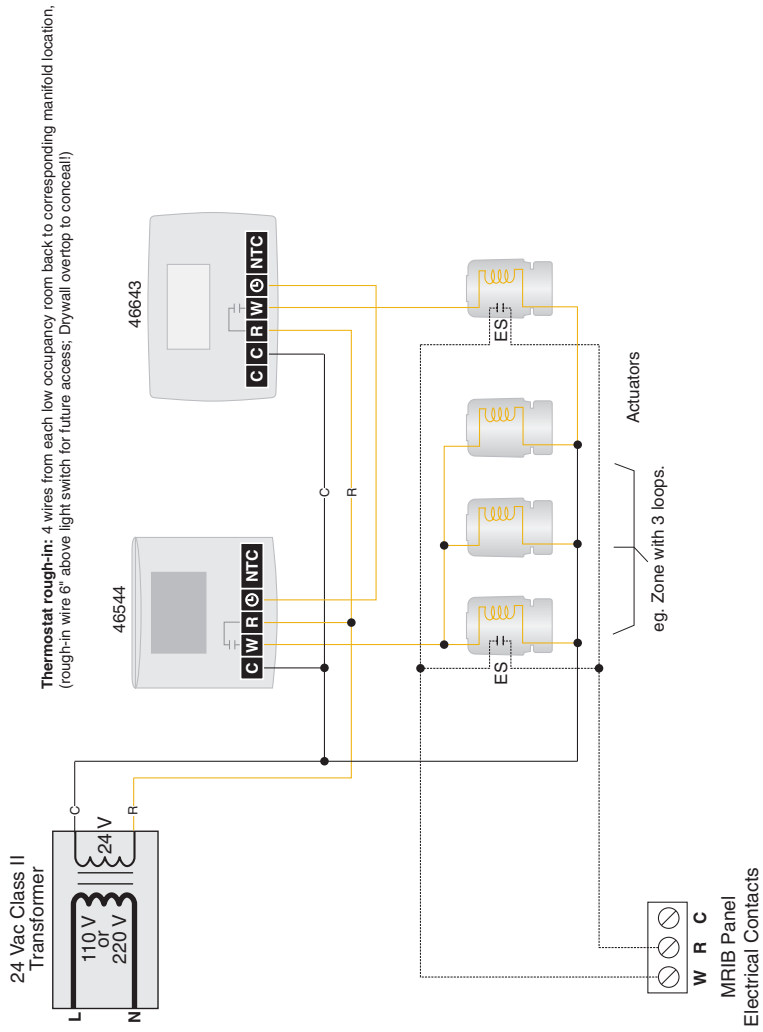

Electrical Schematic for the HeatLink® Mixing Control

Application: Connecting Actuators with end switches to the #31355 Indoor-Outdoor Control.

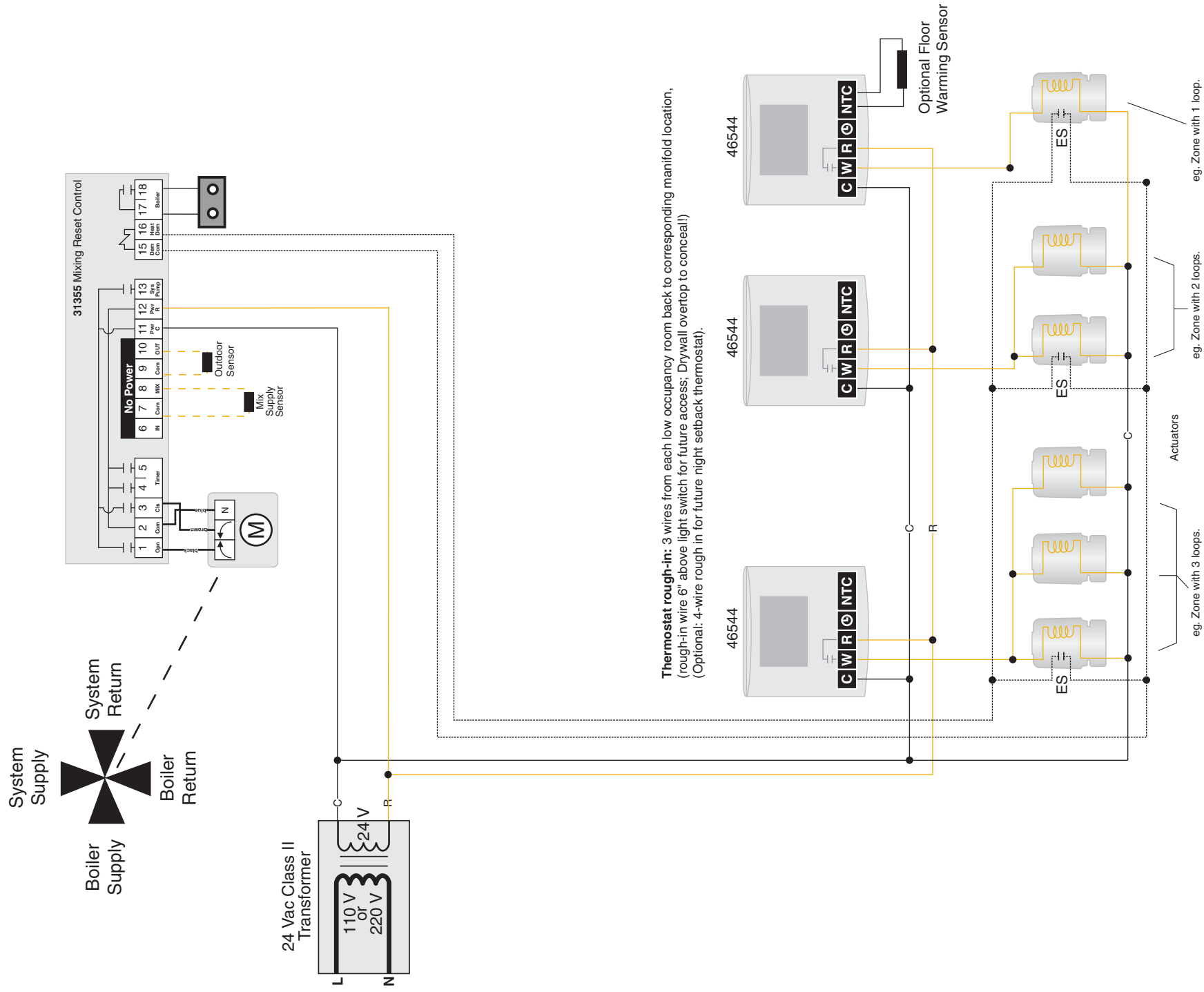

Heat/Cool Thermostat Interlock Wiring

Application: A single cooling zone can often encompass multiple radiant heating zones. A heat/cool thermostat will turn off heating to its zone when cooling is on. However, all the other heating thermostats in the cooling zone may still call for heat. This means that the heating system and cooling system could be active at the same time and work against each other.

Option 1 - Most Comfort:

Heating and cooling systems work independently (and possibly simultaneously, except for the zone controlled by the Heat/Cool Timer Thermostat). This option would be used in floor warming applications.

Advantages: Straight forward wiring; no interlock

Disadvantages: Except for the zone controlled by the heat/cool thermostat, the heating and cooling systems may work against each other depending on thermostat settings and zone environment, resulting in extra energy usage.

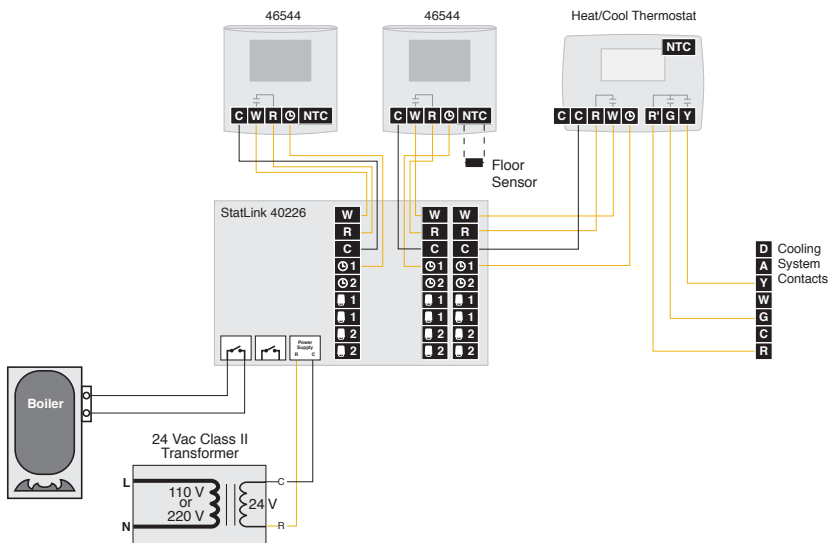

Note: Actuators not shown for simplicity.

Option 2 - Interlock:

When the heat/cool thermostat calls for cooling, the relay will interrupt the heating system's connection to the boiler. This will prevent the boiler from firing.

Advantages: Heating and cooling systems won't be active at the same time.

Disadvantages: Zones that may need heat won't receive any.

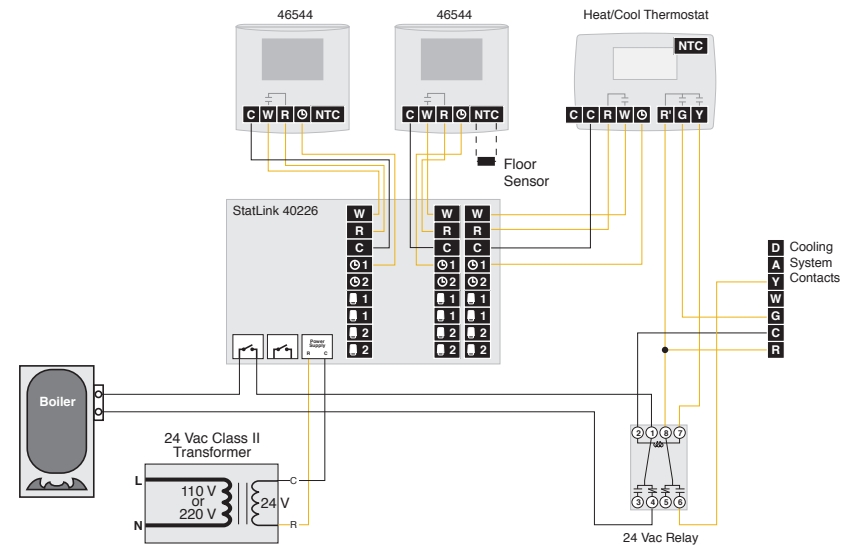

Note: Actuators not shown for simplicity.

Option 3 - Interlock with Outdoor Reset Control:

If the outdoor temperature is warm enough, the heating system will be in Warm Weather Shut Down (WWSD) mode. When the heat/cool thermostat calls for cooling, the relay will interrupt the heating system's connection to the boiler. If the heating system isn't in Warm Weather Shut Down (WWSD), this will prevent the boiler from firing. The heating system pumps will still run, so any heating zones that may be calling for heat will still receive any residual heat in the system.

Advantages: Outdoor temperature feedback

Disadvantages: Outdoor Reset Control required

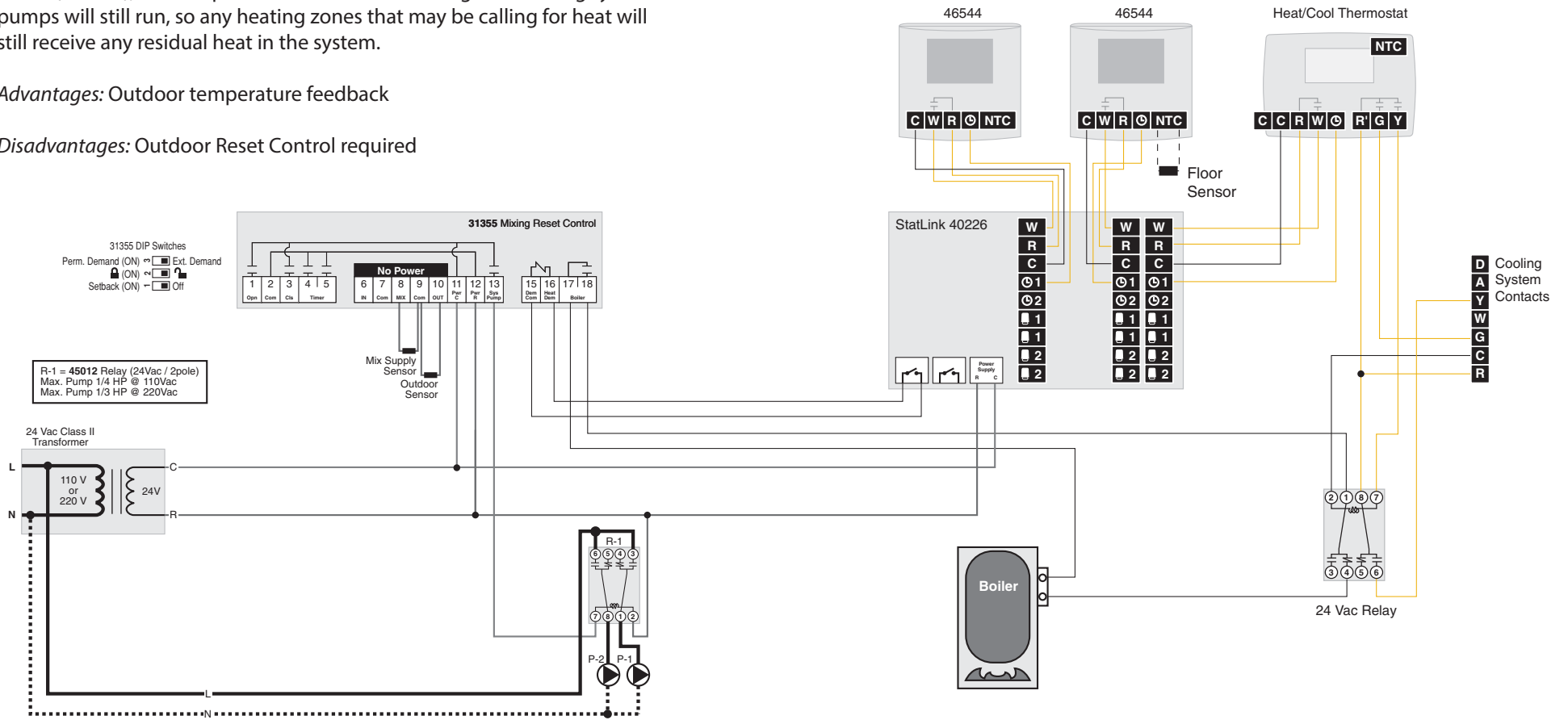

Note: Actuators not shown for simplicity.



www.heatlink.com

HeatLink and StatLink are either registered trademarks or trademarks of HeatLink Group Inc.

L3710

Printed in Canada

© **HeatLink Group Inc.**

October 2015